



YALITIMLI DOĞRAMA SİSTEMİ

506-YSSA

ALUFOUR
DOĞRAMA SİSTEMLERİ



ALUFOUR

YALITIMLI DOĞRAMA SİSTEMİ

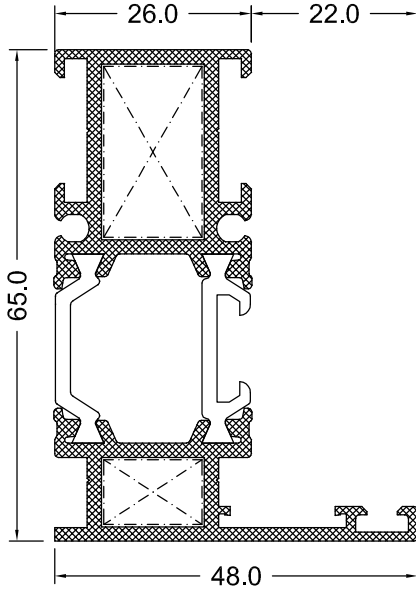

KASA PROFİLİ

PROFİL KODU	AĞIRLIK (kg/m)	KÖŞE GÖNYE	KESİM ÖLÇÜSÜ		I_x	I_y
			ÜST	ALT		
V-6102-16	1.308	TK-130	22.6 mm	8.6 mm	21.82	4.72
V-6102-20	1.414	TK-130	22.6 mm	8.6 mm	23.81	4.91

KASA PROFİLİ

PROFİL KODU	AĞIRLIK (kg/m)	KÖŞE GÖNYE	KESİM ÖLÇÜSÜ		I_x	I_y
			ÜST	ALT		
V-6103-16	1.394	TK-180	22.6 mm	8.6 mm	23.88	6.81
V-6103-20	1.517	TK-180	22.6 mm	8.6 mm	26.77	8.31

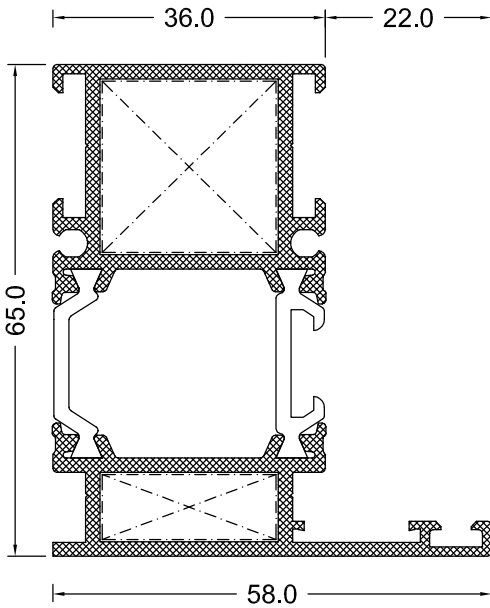
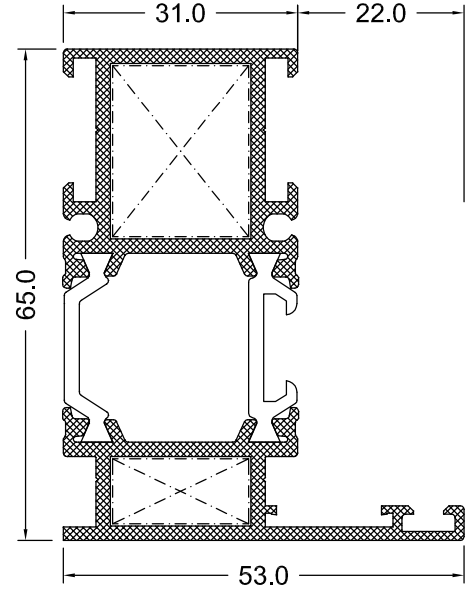

KASA PROFİLİ

PROFİL KODU	AĞIRLIK (kg/m)	KÖŞE GÖNYE	KESİM ÖLÇÜSÜ		I_x	I_y
			ÜST	ALT		
V-6104-16	1.481	TK-230	22.6 mm	8.6 mm	25.98	9.41
V-6104-20	1.606	TK-230	22.6 mm	8.6 mm	28.65	9.94

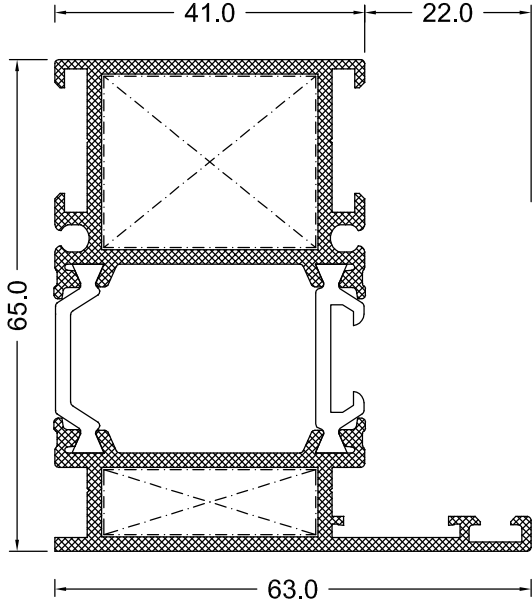

KASA PROFİLİ

PROFİL KODU	AĞIRLIK (kg/m)	KÖŞE GÖNYE	KESİM ÖLÇÜSÜ		I _x	I _y
			ÜST	ALT		
V-6105-16	1.630	TK-280	22.6 mm	8.6 mm	29.77	15.24
V-6105-20	1.708	TK-280	22.6 mm	8.6 mm	31.82	15.73

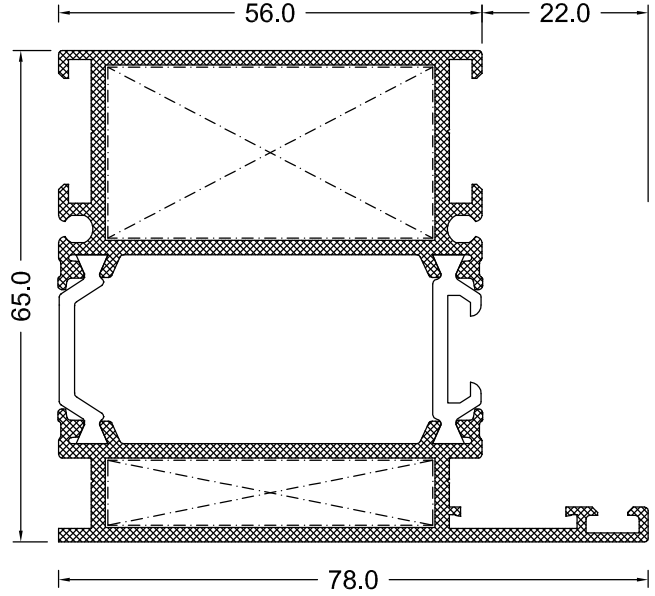

KASA PROFİLİ

PROFİL KODU	AĞIRLIK (kg/m)	KÖŞE GÖNYE	KESİM ÖLÇÜSÜ		I _x	I _y
			ÜST	ALT		
V-6106-16	1.828	TK-430	22.6 mm	8.6 mm	35.81	24.73
V-6106-20	2.032	TK-430	22.6 mm	8.6 mm	39.62	26.91

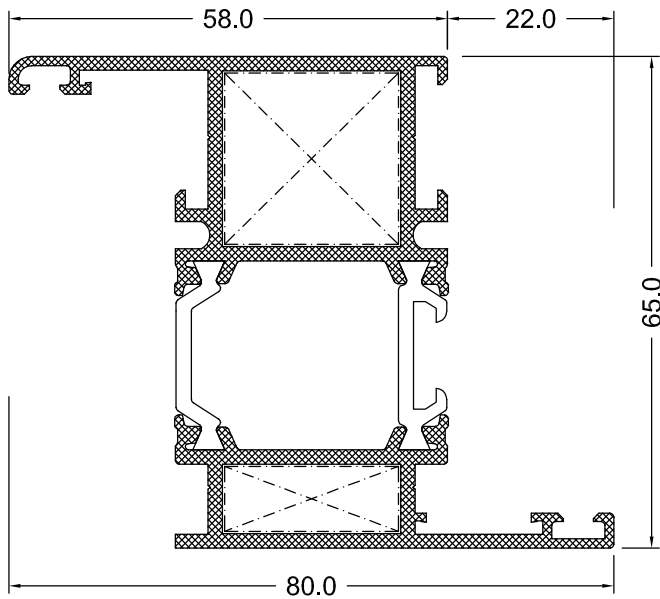

Z KASA PROFİLİ

PROFİL KODU	AĞIRLIK (kg/m)	KÖŞE GÖNYE	KESİM ÖLÇÜSÜ		I _x	I _y
			ÜST	ALT		
V-6109-20	1.739	TK-230	22.6 mm	8.6 mm	36.39	11.83

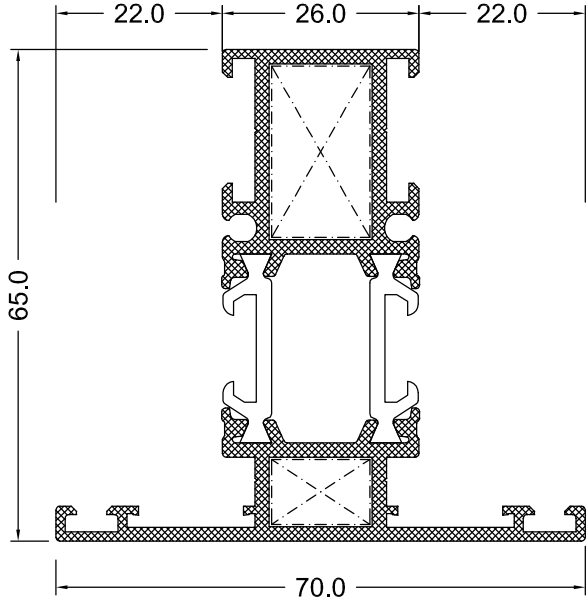

ORTA KAYIT PROFİLİ

PROFİL KODU	AĞIRLIK (kg/m)	KÖŞE GÖNYE	KESİM ÖLÇÜSÜ		I _x	I _y
			ÜST	ALT		
V-6202-12	1.295	TK-130	22.6 mm	8.6 mm	20.92	8.04
V-6202-16	1.446	TK-130	22.6 mm	8.6 mm	24.30	8.55
V-6202-20	1.547	TK-130	22.6 mm	8.6 mm	26.54	8.82

ORTA KAYIT PROFİLİ

PROFİL KODU	AĞIRLIK (kg/m)	KÖŞE GÖNYE	KESİM ÖLÇÜSÜ		I _x	I _y
			ÜST	ALT		
V-6203-12	1.360	TK-180	22.6 mm	8.6 mm	22.40	10.62
V-6203-16	1.533	TK-180	22.6 mm	8.6 mm	26.26	11.39
V-6203-20	1.650	TK-180	22.6 mm	8.6 mm	28.85	11.82

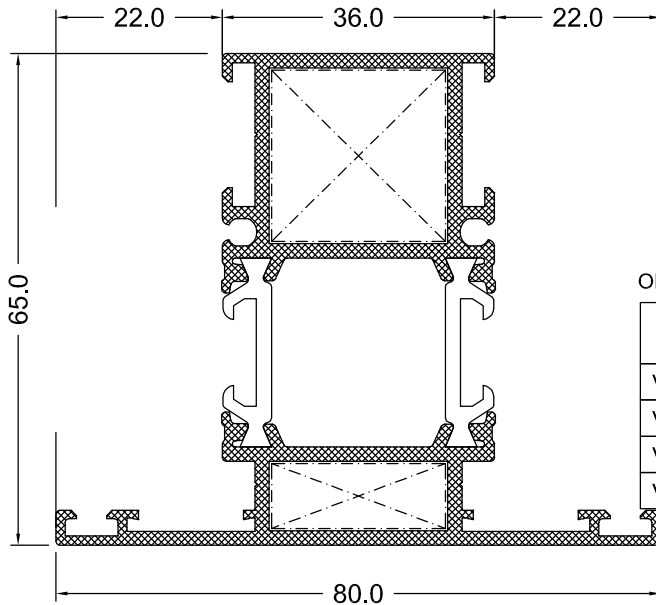
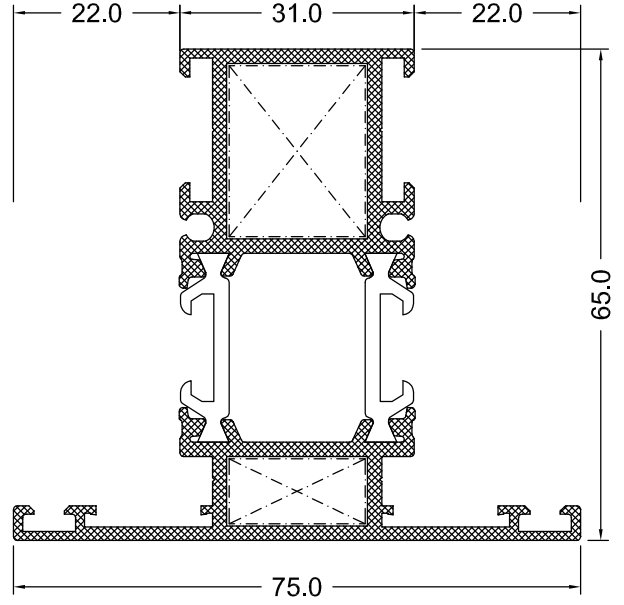

ORTA KAYIT PROFİLİ

PROFİL KODU	AĞIRLIK (kg/m)	KÖŞE GÖNYE	KESİM ÖLÇÜSÜ		I _x	I _y
			ÜST	ALT		
V-6204-12	1.425	TK-230	22.6 mm	8.6 mm	23.88	13.74
V-6204-16	1.620	TK-230	22.6 mm	8.6 mm	28.21	14.84
V-6204-18	1.699	TK-230	22.6 mm	8.6 mm	30.25	15.16
V-6204-20	1.753	TK-230	22.6 mm	8.6 mm	31.15	15.49

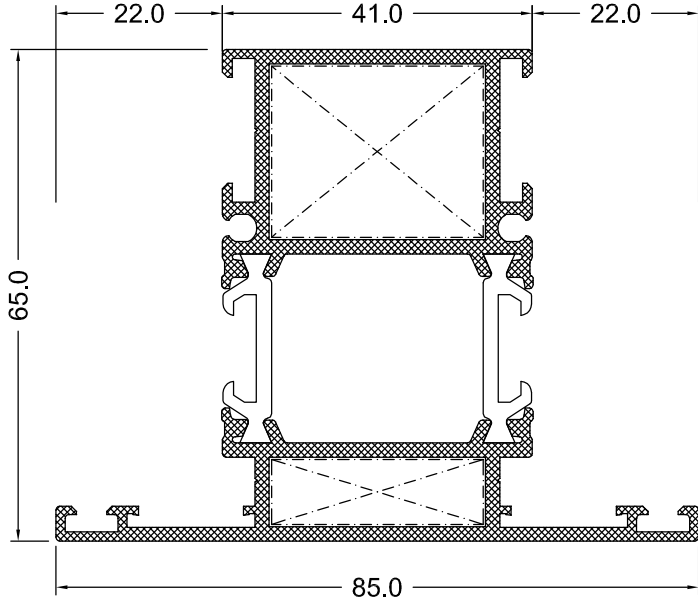

ORTA KAYIT PROFİLİ

PROFİL KODU	AĞIRLIK (kg/m)	KÖŞE GÖNYE	KESİM ÖLÇÜSÜ		I_x	I_y
			ÜST	ALT		
V-6205-12	1.490	TK-280	22.6 mm	8.6 mm	25.35	17.42
V-6205-16	1.707	TK-280	22.6 mm	8.6 mm	30.16	18.95
V-6205-20	1.853	TK-280	22.6 mm	8.6 mm	33.45	19.87

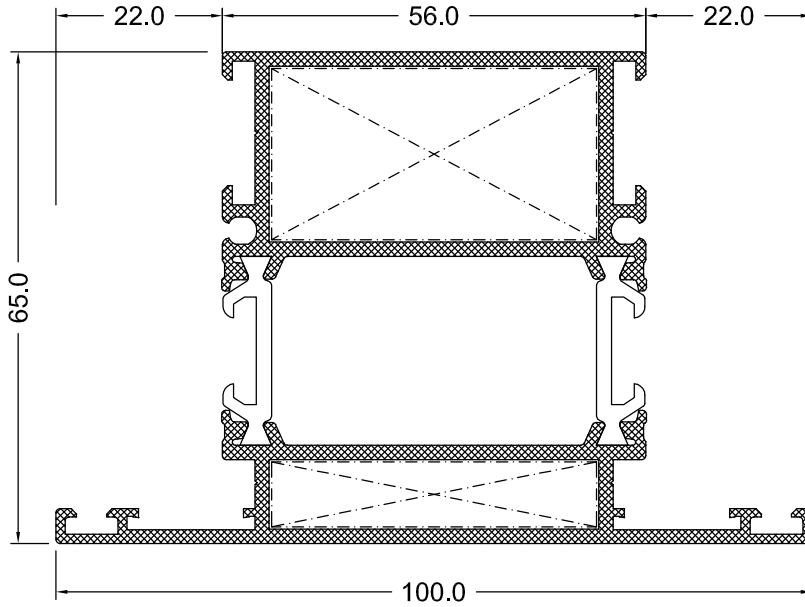

ORTA KAYIT PROFİLİ

PROFİL KODU	AĞIRLIK (kg/m)	KÖŞE GÖNYE	KESİM ÖLÇÜSÜ		I_x	I_y
			ÜST	ALT		
V-6209-12	1.685	TK-430	22.6 mm	8.6 mm	29.77	32.13
V-6209-16	1.967	TK-430	22.6 mm	8.6 mm	36.00	35.57
V-6209-20	2.162	TK-430	22.6 mm	8.6 mm	40.34	37.75

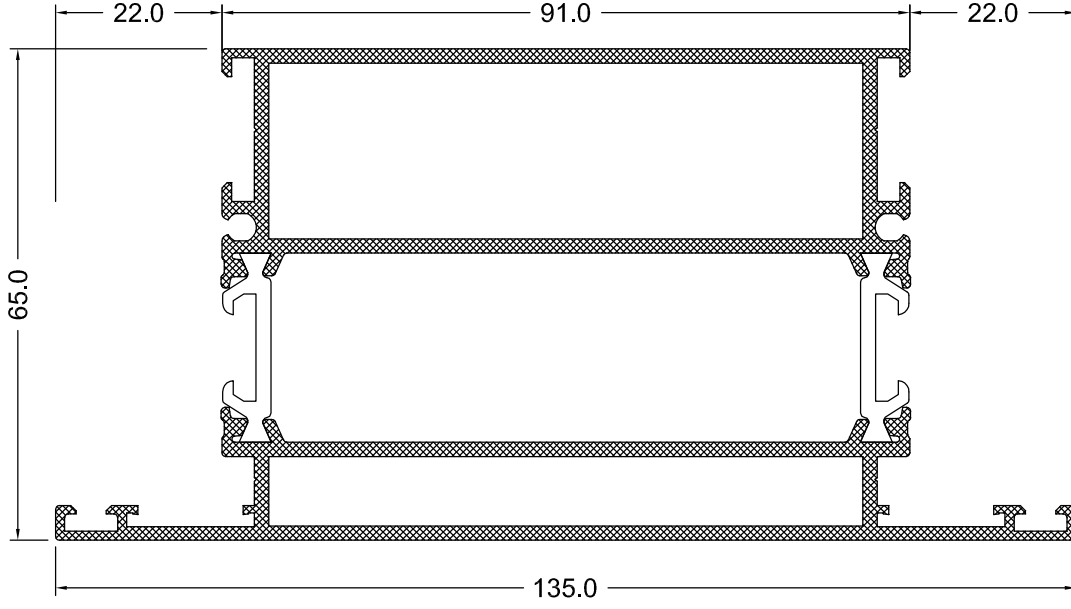

ORTA KAYIT PROFİLİ

PROFİL KODU	AĞIRLIK (kg/m)	KÖŞE GÖNYE	KESİM ÖLÇÜSÜ		I_x	I_y
			ÜST	ALT		
V-6235-12	2.110	---	---	---	39.39	90.06
V-6235-16	2.563	---	---	---	49.31	103.90
V-6235-20	2.885	---	---	---	56.38	113.28

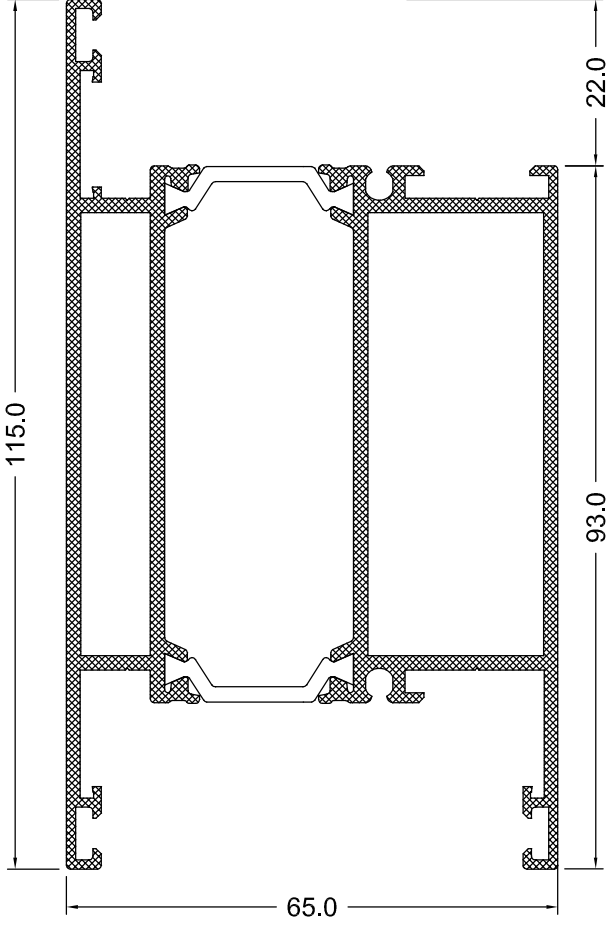

DAR ETEK PROFİLİ

PROFİL KODU	AĞIRLIK (kg/m)	KÖŞE GÖNYE	KESİM ÖLÇÜSÜ		I _x	I _y
			ÜST	ALT		
V-6173-16	2.299	---	---	---	---	---
V-6173-20	2.567	---	---	---	---	---

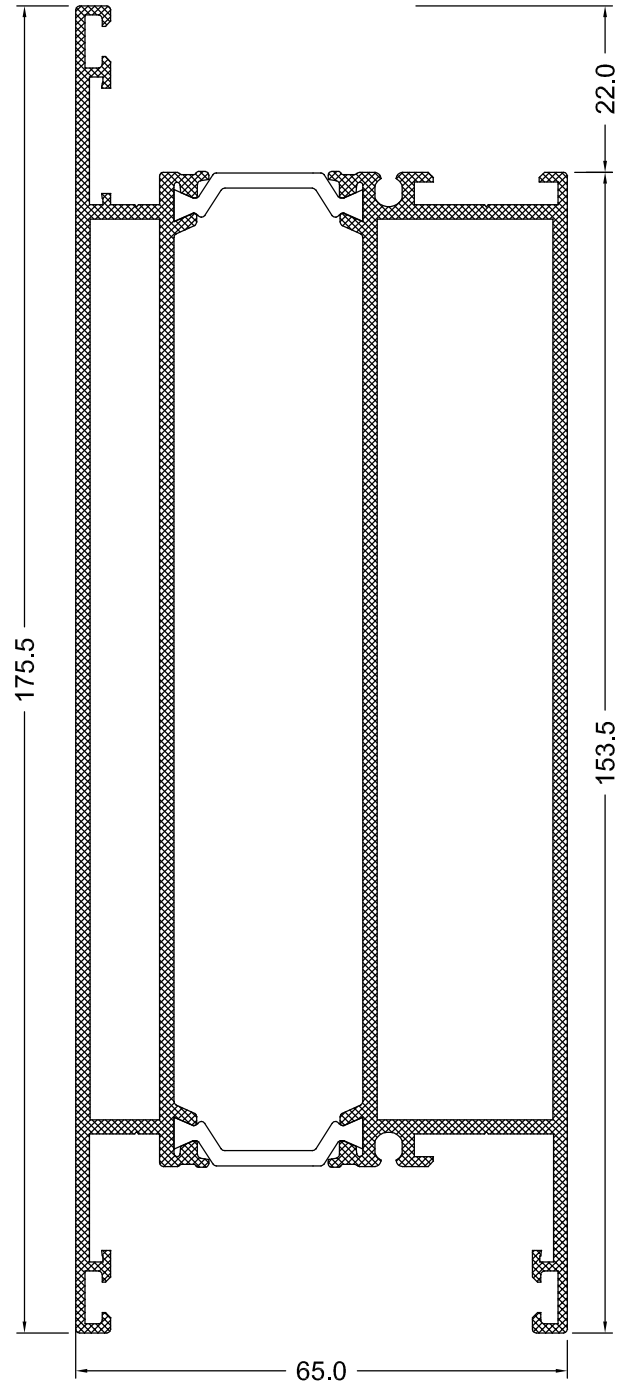

ETEK PROFİLİ

PROFİL KODU	AĞIRLIK (kg/m)	KÖŞE GÖNYE	KESİM ÖLÇÜSÜ		I _x	I _y
			ÜST	ALT		
V-6175-16	3.349	---	---	---	---	---
V-6175-20	3.811	---	---	---	---	---

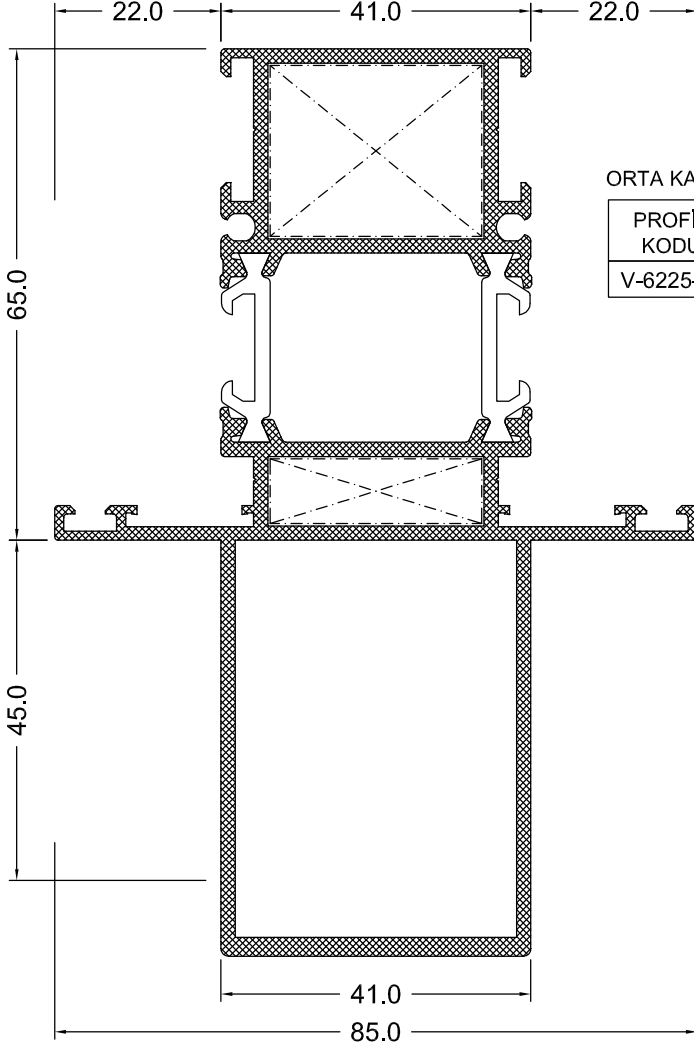

ORTA KAYIT PROFİLİ

PROFİL KODU	AĞIRLIK (kg/m)	KÖŞE GÖNYE	KESİM ÖLÇÜSÜ		I_x	I_y
			ÜST	ALT		
V-6225-20	2.671	TK-280	22.6 mm	8.6 mm	121.66	28.91

ORTA KAYIT PROFİLİ

PROFİL KODU	AĞIRLIK (kg/m)	KÖŞE GÖNYE	KESİM ÖLÇÜSÜ		I_x	I_y
			ÜST	ALT		
V-6226-20	2.527	TK-280	22.6 mm	8.6 mm	121.55	23.57

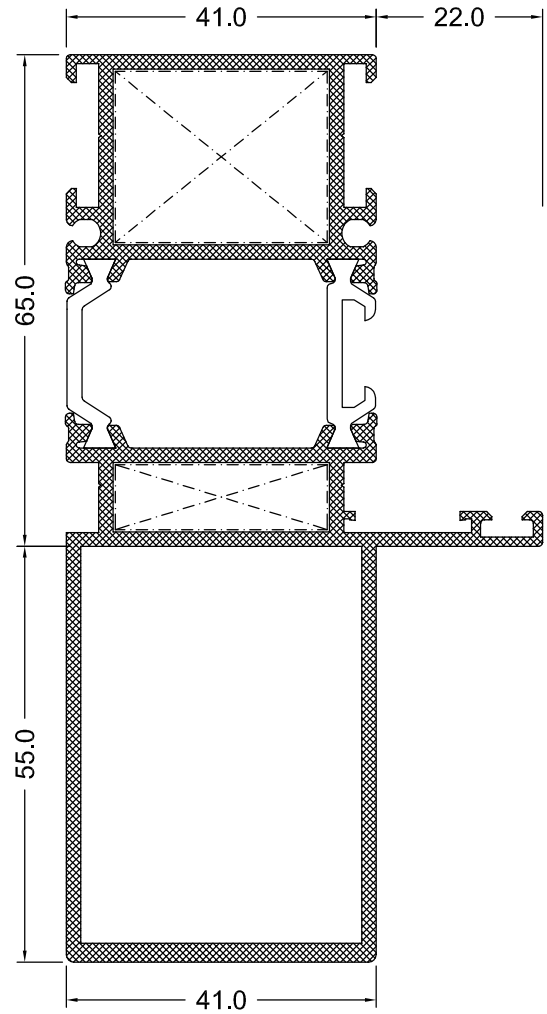

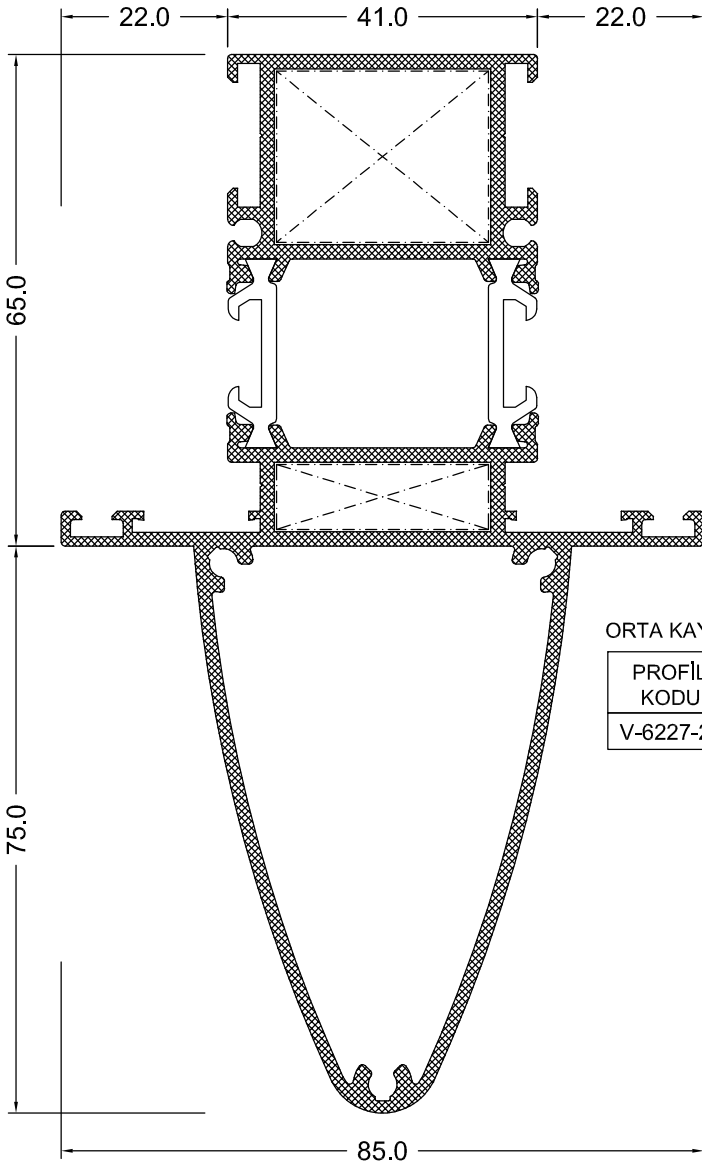

ORTA KAYIT PROFİLİ

PROFİL KODU	AĞIRLIK (kg/m)	KÖŞE GÖNYE	KESİM ÖLÇÜSÜ		I_x	I_y
			ÜST	ALT		
V-6227-20	2.707	TK-280	22.6 mm	8.6 mm	137.59	29.09

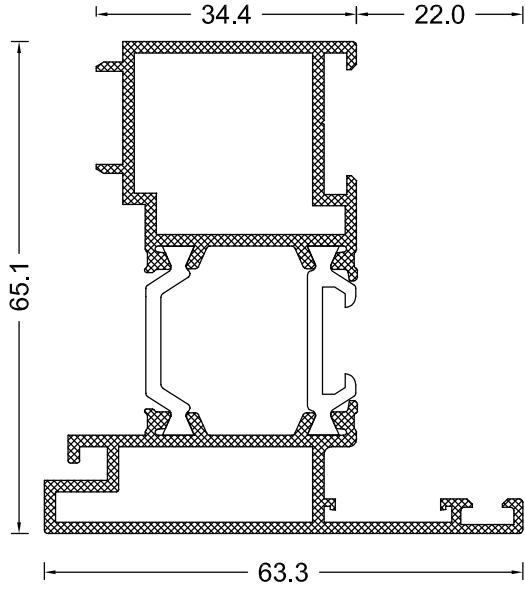

ÇİFT KANAT ADAPTÖRÜ

PROFİL KODU	AĞIRLIK (kg/m)	KÖŞE GÖNYE	KESİM ÖLÇÜSÜ		I _x	I _y
			ÜST	ALT		
V-6502-15	1.411	---	---	---	---	---

DIŞA AÇILIR KAPI ADAPTÖRÜ

PROFİL KODU	AĞIRLIK (kg/m)	KÖŞE GÖNYE	KESİM ÖLÇÜSÜ		I _x	I _y
			ÜST	ALT		
V-6503-16	1.270	---	---	---	---	---

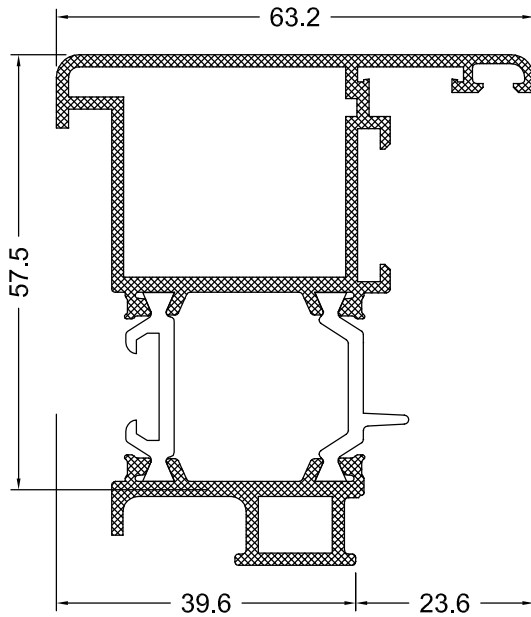
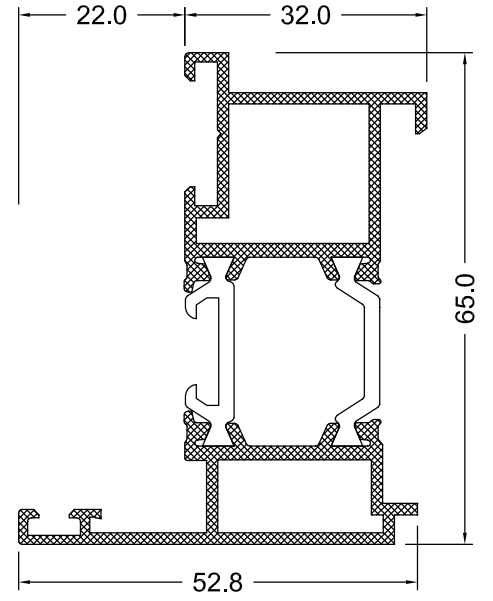

PİVOT AÇILIM ADAPTÖRÜ

PROFİL KODU	AĞIRLIK (kg/m)	KÖŞE GÖNYE	KESİM ÖLÇÜSÜ		I _x	I _y
			ÜST	ALT		
V-6504-16	1.507	---	---	---	---	---

135° OVAL KÖŞE

PROFİL KODU	AĞIRLIK (kg/m)	KÖŞE GÖNYE	KESİM ÖLÇÜSÜ		I_x	I_y
			ÜST	ALT		
V-6603-16	1.405	---	---	---	---	---

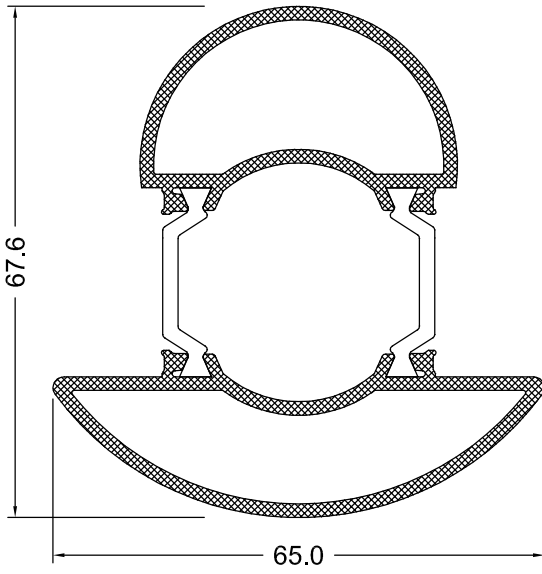
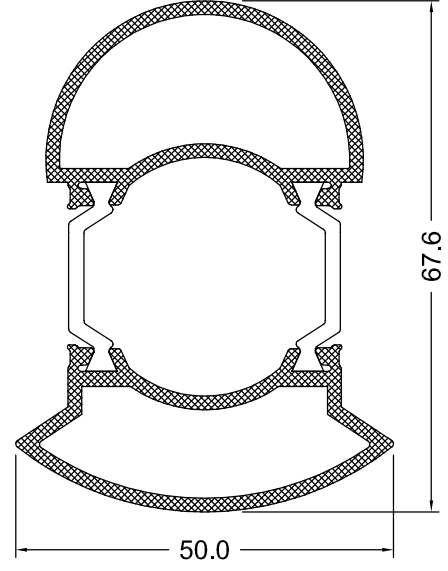

90° DÜZ KÖŞE

PROFİL KODU	AĞIRLIK (kg/m)	KÖŞE GÖNYE	KESİM ÖLÇÜSÜ	I_x	I_y
V-6604-16	1.535	---	---	---	---

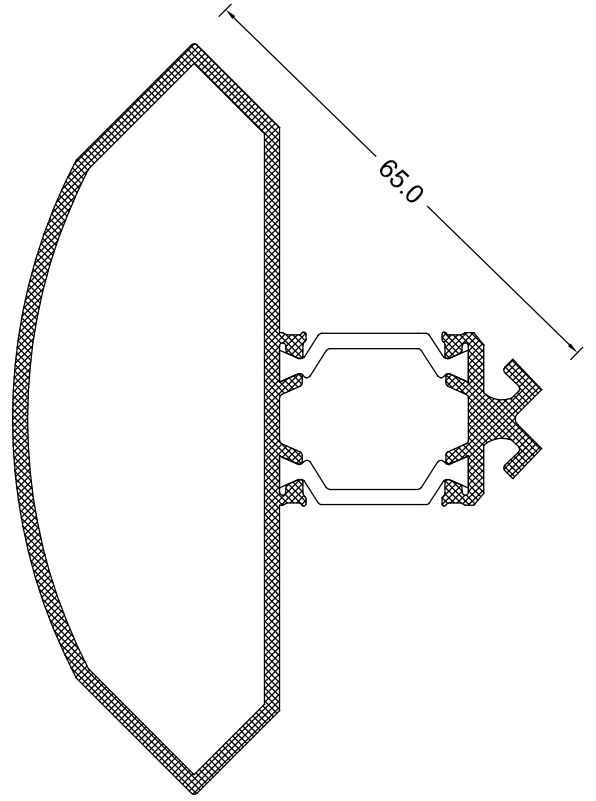

90° OVAL KÖŞE

PROFİL KODU	AĞIRLIK (kg/m)	KÖŞE GÖNYE	KESİM ÖLÇÜSÜ		I _x	I _y
			ÜST	ALT		
V-6602-15	1.522	---	---	---	---	---

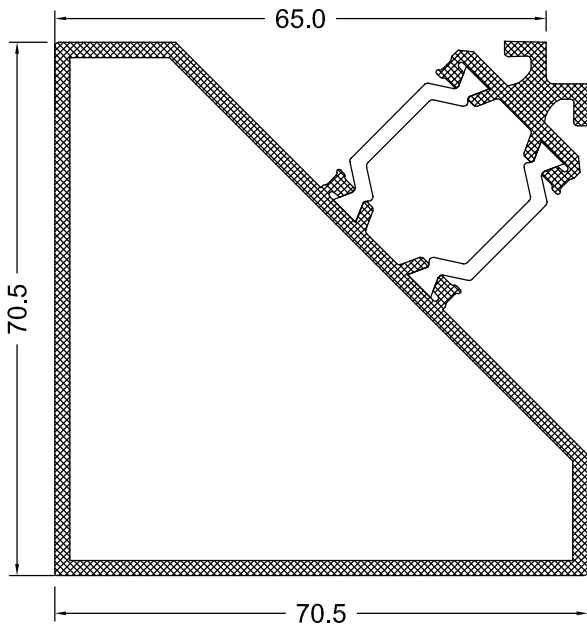

90° KÖŞE

PROFİL KODU	AĞIRLIK (kg/m)	KÖŞE GÖNYE	KESİM ÖLÇÜSÜ		I _x	I _y
			ÜST	ALT		
V-6605-15	1.727	---	---	---	---	---

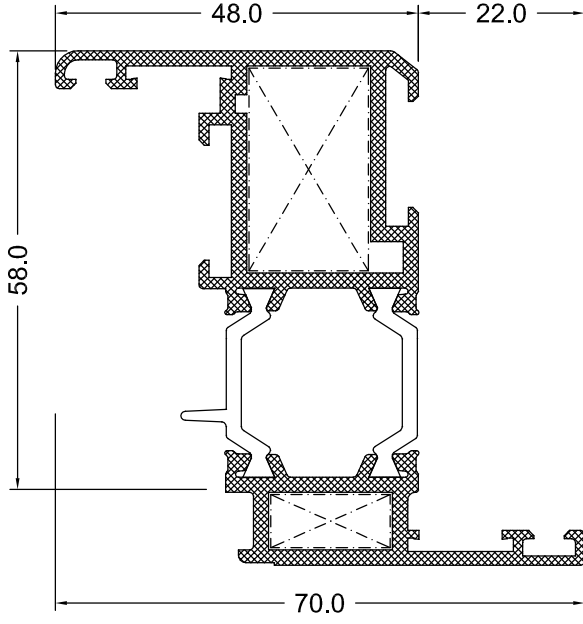

KANAT PROFİLİ

PROFİL KODU	AĞIRLIK (kg/m)	KÖŞE GÖNYE	KESİM ÖLÇÜSÜ		I _x	I _y
			ÜST	ALT		
V-6302-16	1.460	TK-158	26.8 mm	7.0 mm	----	----
V-6302-20	1.612	TK-158	26.8 mm	7.0 mm	----	----

KANAT PROFİLİ

PROFİL KODU	AĞIRLIK (kg/m)	KÖŞE GÖNYE	KESİM ÖLÇÜSÜ		I _x	I _y
			ÜST	ALT		
V-6303-16	1.547	TK-208	26.8 mm	7.0 mm	----	----
V-6303-20	1.718	TK-208	26.8 mm	7.0 mm	----	----

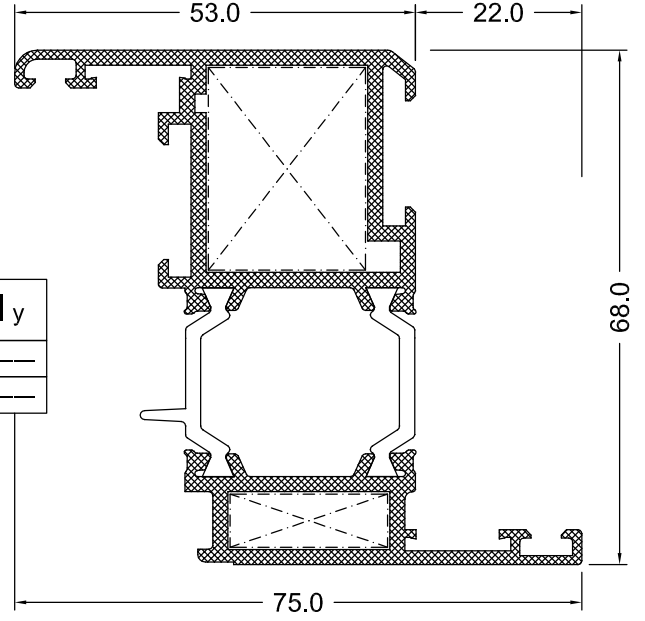

KANAT PROFİLİ

PROFİL KODU	AĞIRLIK (kg/m)	KÖŞE GÖNYE	KESİM ÖLÇÜSÜ		I _x	I _y
			ÜST	ALT		
V-6304-16	1.634	TK-258	26.8 mm	7.0 mm	----	----
V-6304-20	1.826	TK-258	26.8 mm	7.0 mm	----	----

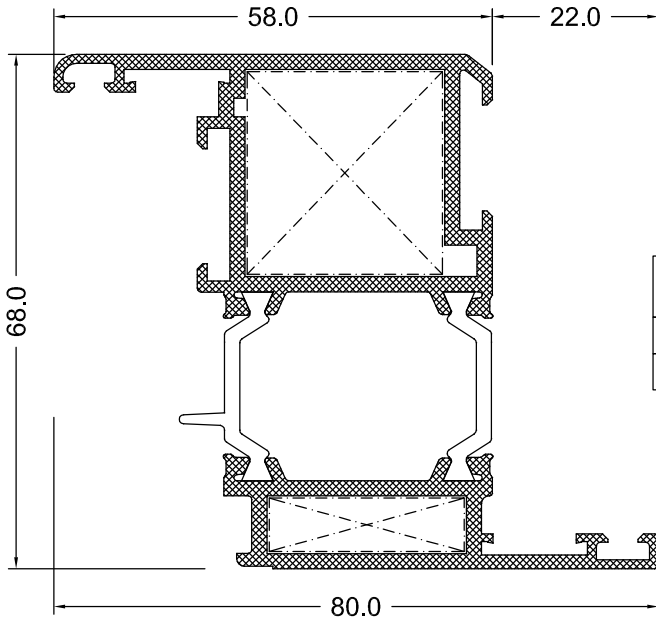

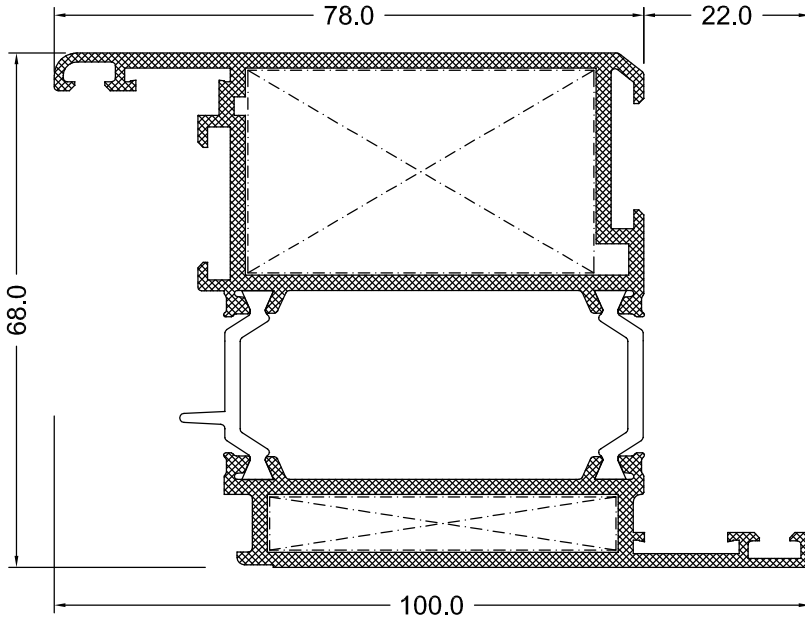

KAPI KANAT PROFİLİ

PROFİL KODU	AĞIRLIK (kg/m)	KÖŞE GÖNYE	KESİM ÖLÇÜSÜ		I _x	I _y
			ÜST	ALT		
V-6308-16	1.981	TK-458	26.8 mm	7.0 mm	----	----
V-6308-20	2.260	TK-458	26.8 mm	7.0 mm	----	----

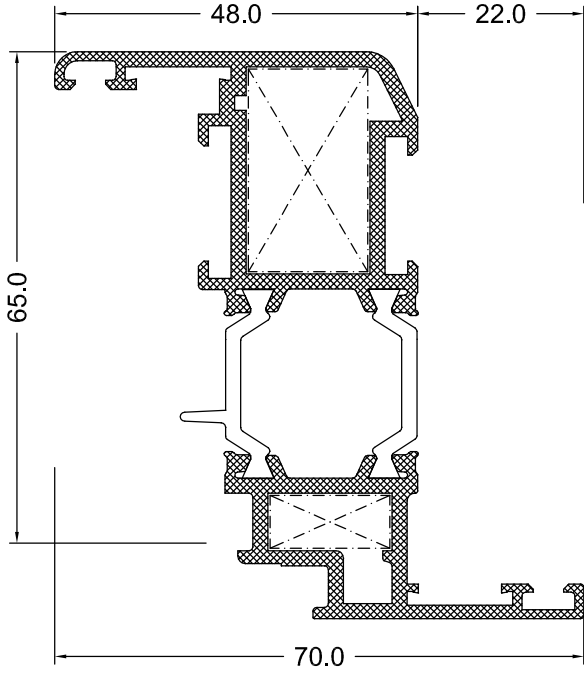

HEMYÜZ KANAT PROFİLİ

PROFİL KODU	AĞIRLIK (kg/m)	KÖŞE GÖNYE	KESİM ÖLÇÜSÜ		I_x	I_y
			ÜST	ALT		
V-6332-16	1.504	TK-158	26.8 mm	7.0 mm	---	---
V-6332-20	1.682	TK-158	26.8 mm	7.0 mm	---	---

HEMYÜZ KANAT PROFİLİ

PROFİL KODU	AĞIRLIK (kg/m)	KÖŞE GÖNYE	KESİM ÖLÇÜSÜ		I_x	I_y
			ÜST	ALT		
V-6333-16	1.590	TK-208	26.8 mm	7.0 mm	---	---
V-6333-20	1.791	TK-208	26.8 mm	7.0 mm	---	---

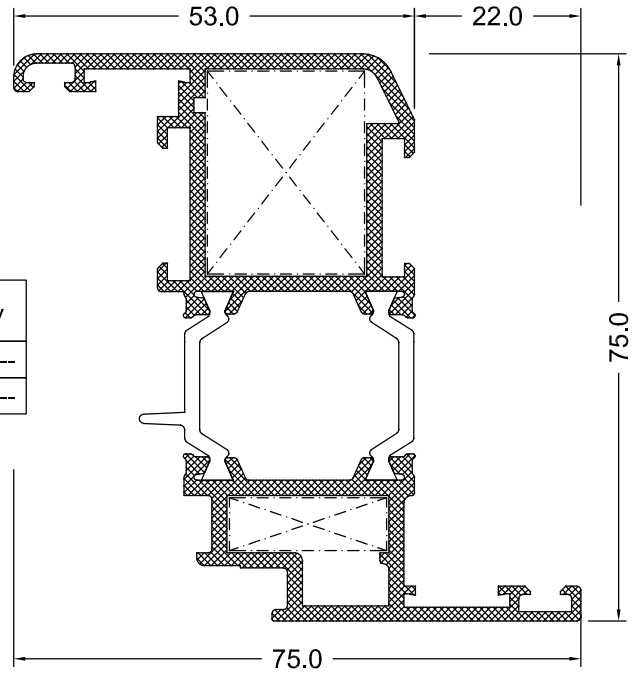

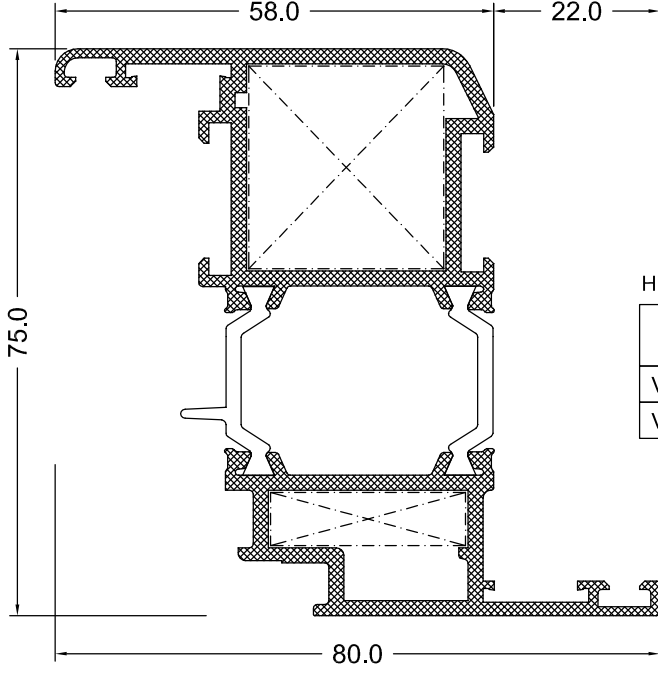

HEMYÜZ KANAT PROFİLİ

PROFİL KODU	AĞIRLIK (kg/m)	KÖŞE GÖNYE	KESİM ÖLÇÜSÜ		I _x	I _y
			ÜST	ALT		
V-6334-16	1.677	TK-258	26.8 mm	7.0 mm	---	---
V-6334-20	1.899	TK-258	26.8 mm	7.0 mm	---	---

HEMYÜZ KANAT PROFİLİ

PROFİL KODU	AĞIRLIK (kg/m)	KÖŞE GÖNYE	KESİM ÖLÇÜSÜ		I _x	I _y
			ÜST	ALT		
V-6335-16	1.733	ÜST TK-180 ÜST TK-258	26.8 mm	7.0 mm	---	---
V-6335-20	1.970	ÜST TK-180 ÜST TK-258	26.8 mm	7.0 mm	---	---

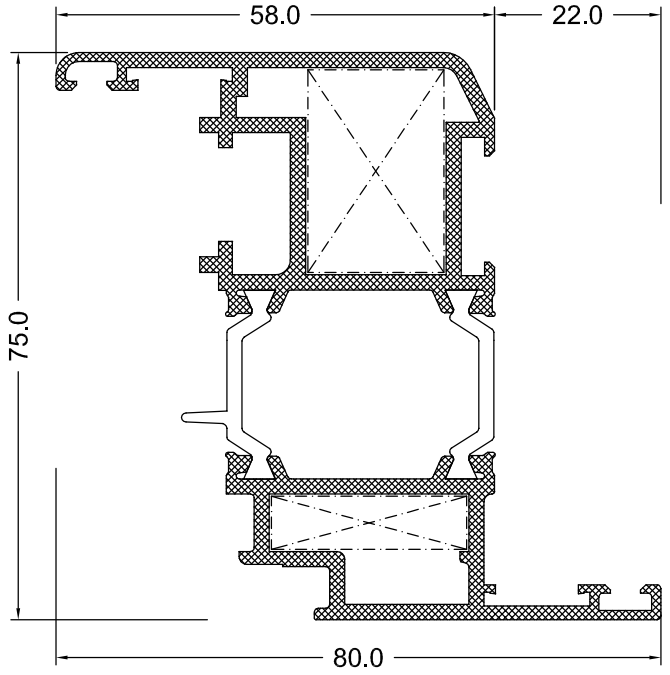

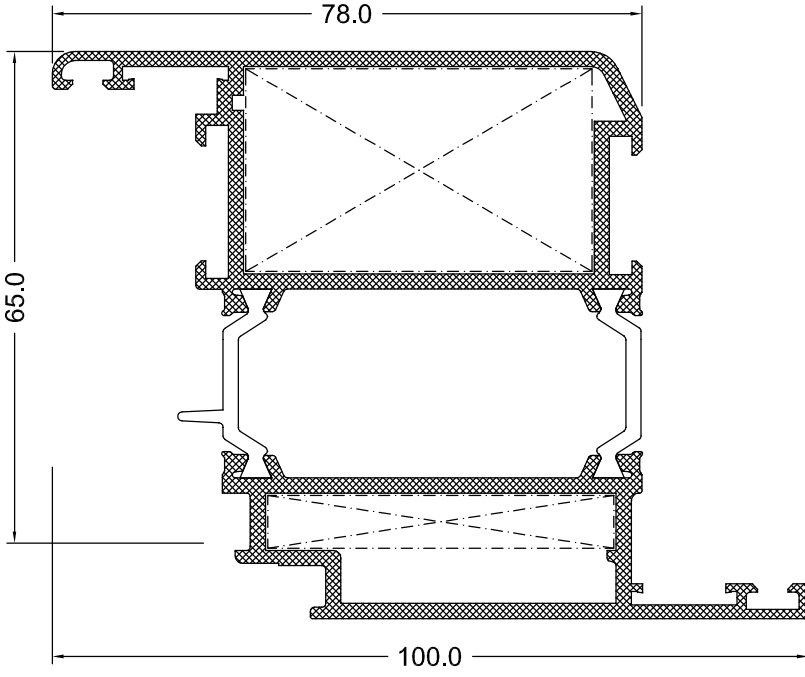

HEMYÜZ KAPI KANAT PROFİLİ

PROFİL KODU	AĞIRLIK (kg/m)	KÖŞE GÖNYE	KESİM ÖLÇÜSÜ		I _x	I _y
			ÜST	ALT		
V-6338-16	2.024	TK-430	26.8 mm	7.0 mm	---	---
V-6338-20	2.333	TK-430	26.8 mm	7.0 mm	---	---

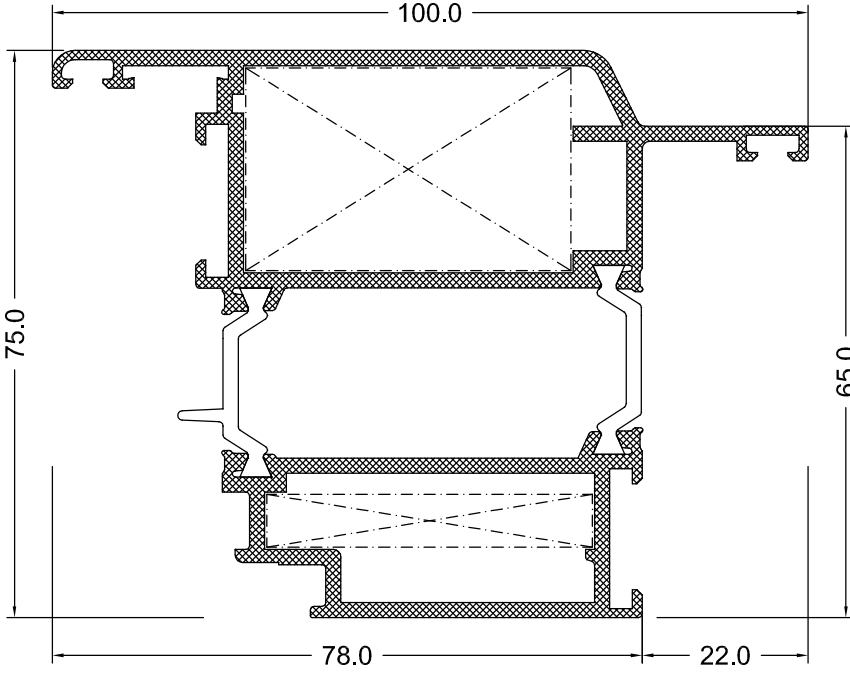

HEMYÜZ DIŞA AÇILIR KAPI KANAT PROFİLİ

PROFİL KODU	AĞIRLIK (kg/m)	KÖŞE GÖNYE	KESİM ÖLÇÜSÜ		I _x	I _y
			ÜST	ALT		
V-6352-16	2.065	TK-430	26.8 mm	7.0 mm	---	---
V-6352-20	2.352	TK-430	26.8 mm	7.0 mm	---	---

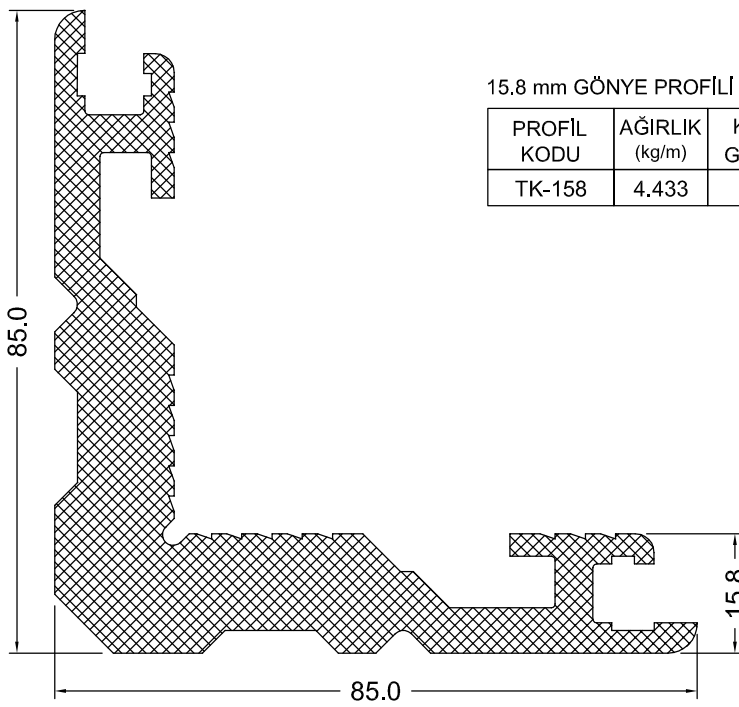
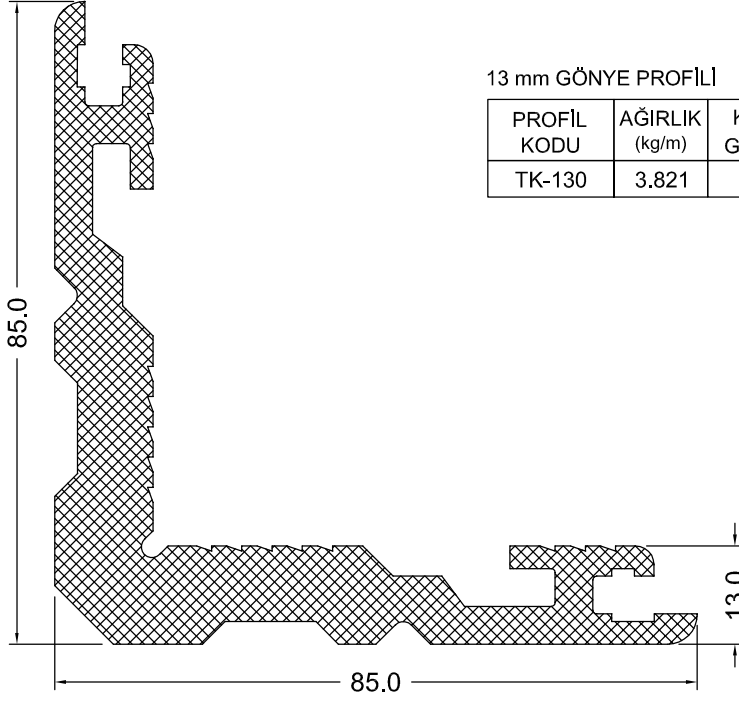

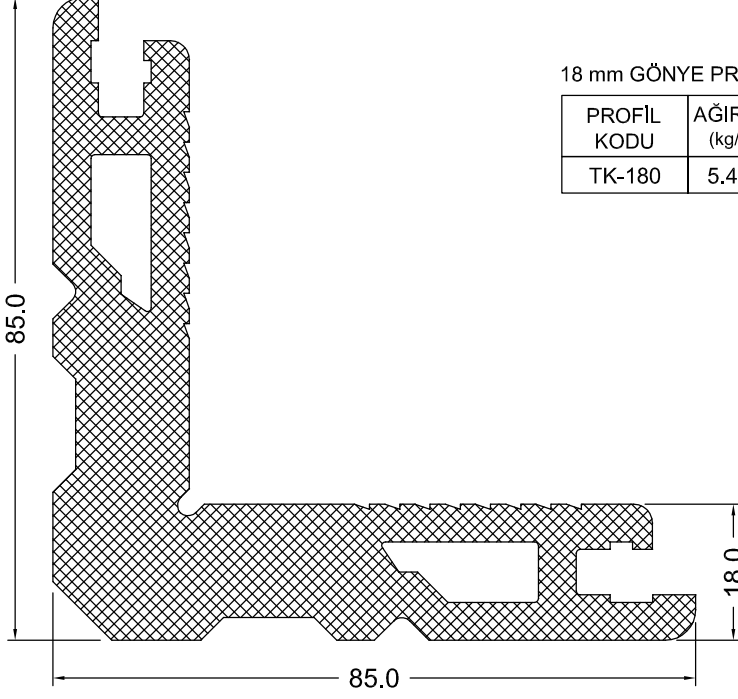

18 mm GÖNYE PROFİLİ

PROFİL KODU	AĞIRLIK (kg/m)	KÖŞE GÖNYE	KESİM ÖLÇÜSÜ		I _x	I _y
			ÜST	ALT		
TK-180	5,474	---	---	---	---	---

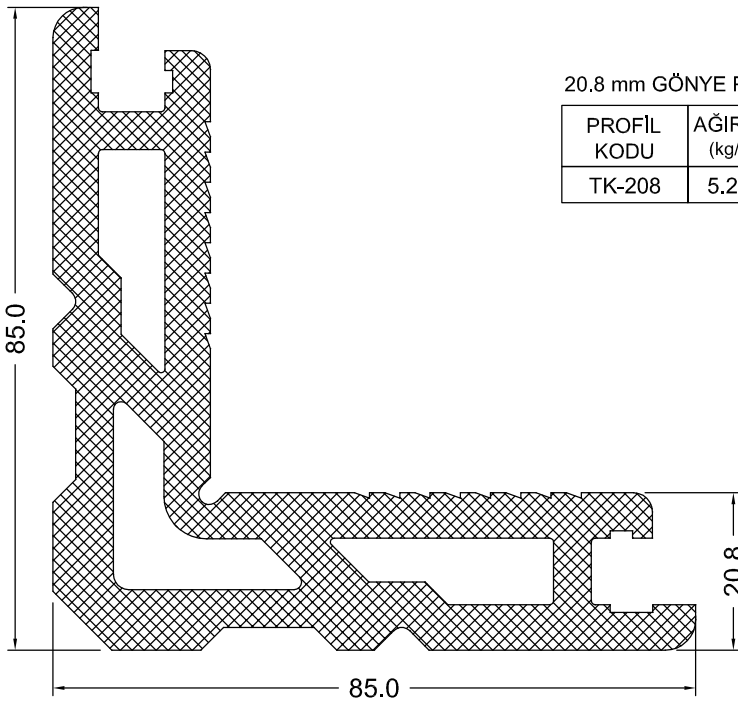

20.8 mm GÖNYE PROFİLİ

PROFİL KODU	AĞIRLIK (kg/m)	KÖŞE GÖNYE	KESİM ÖLÇÜSÜ		I _x	I _y
			ÜST	ALT		
TK-208	5,225	---	---	---	---	---

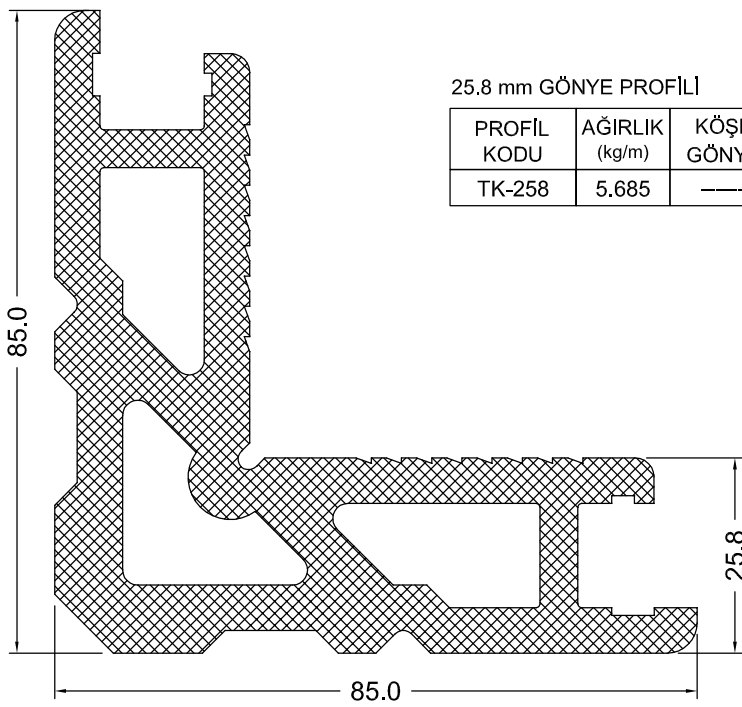
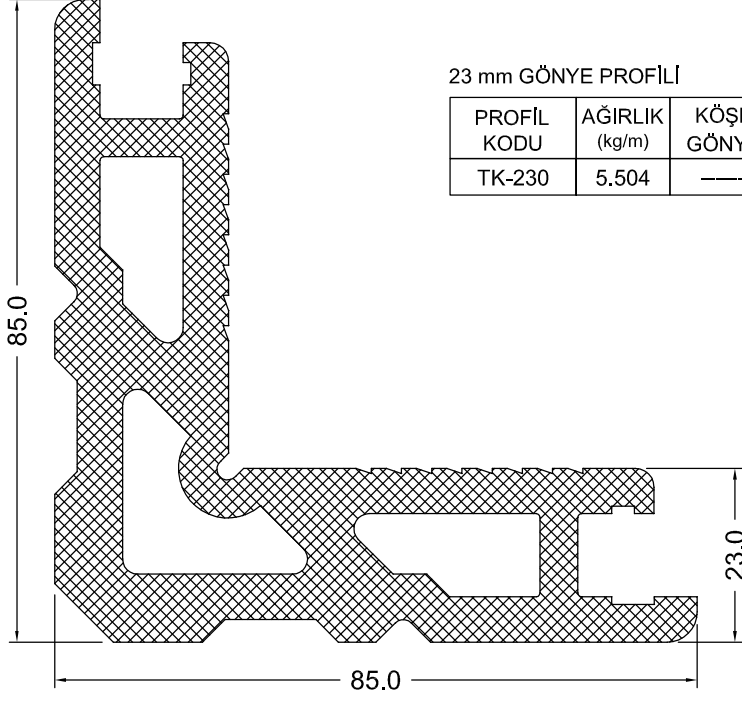

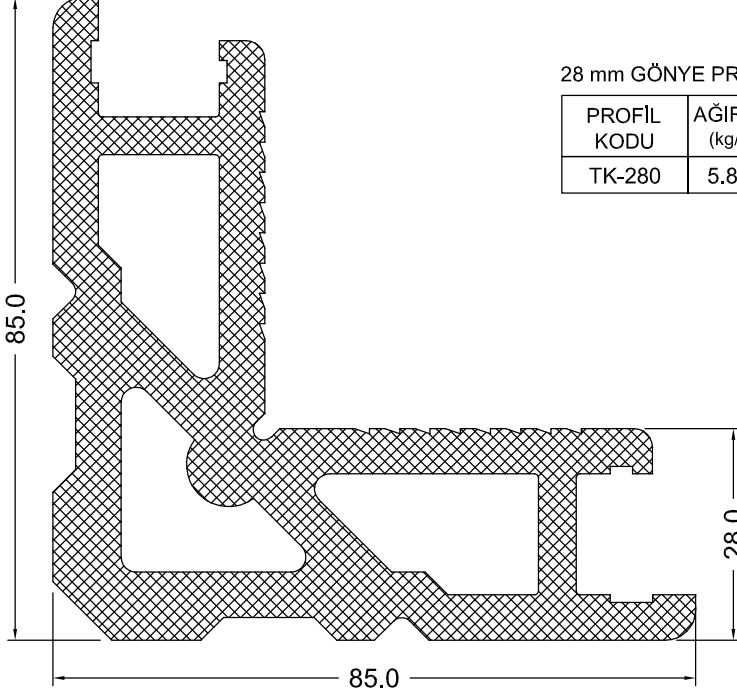

28 mm GÖNYE PROFİLİ

PROFİL KODU	AĞIRLIK (kg/m)	KÖŞE GÖNYE	KESİM ÖLÇÜSÜ		I _x	I _y
			ÜST	ALT		
TK-280	5.816	---	---	---	---	---

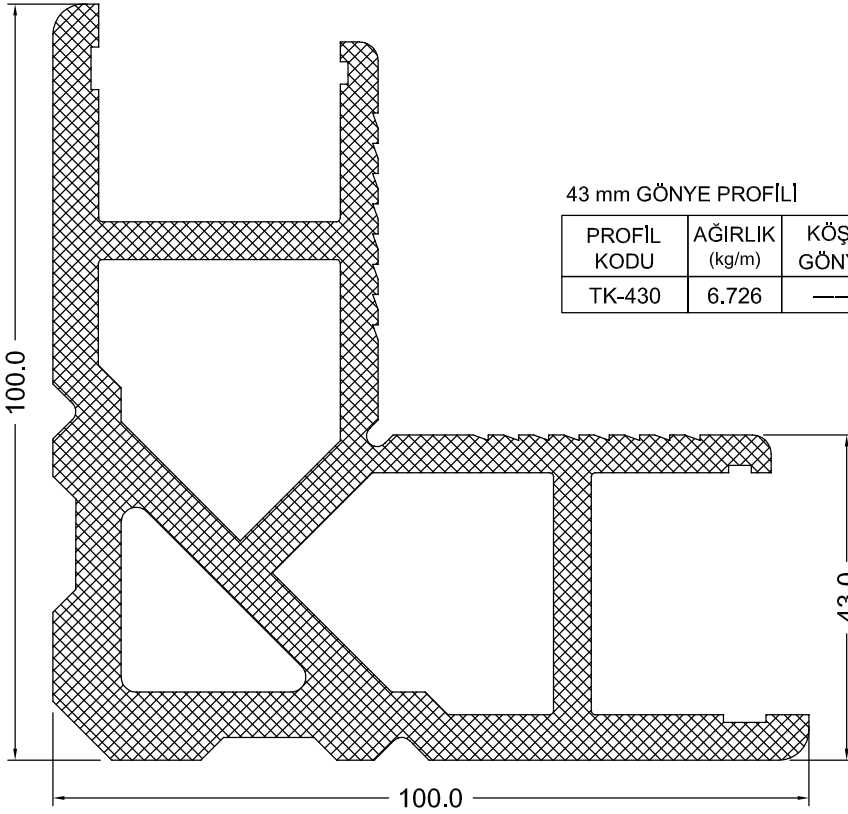

43 mm GÖNYE PROFİLİ

PROFİL KODU	AĞIRLIK (kg/m)	KÖŞE GÖNYE	KESİM ÖLÇÜSÜ		I _x	I _y
			ÜST	ALT		
TK-430	6.726	---	---	---	---	---

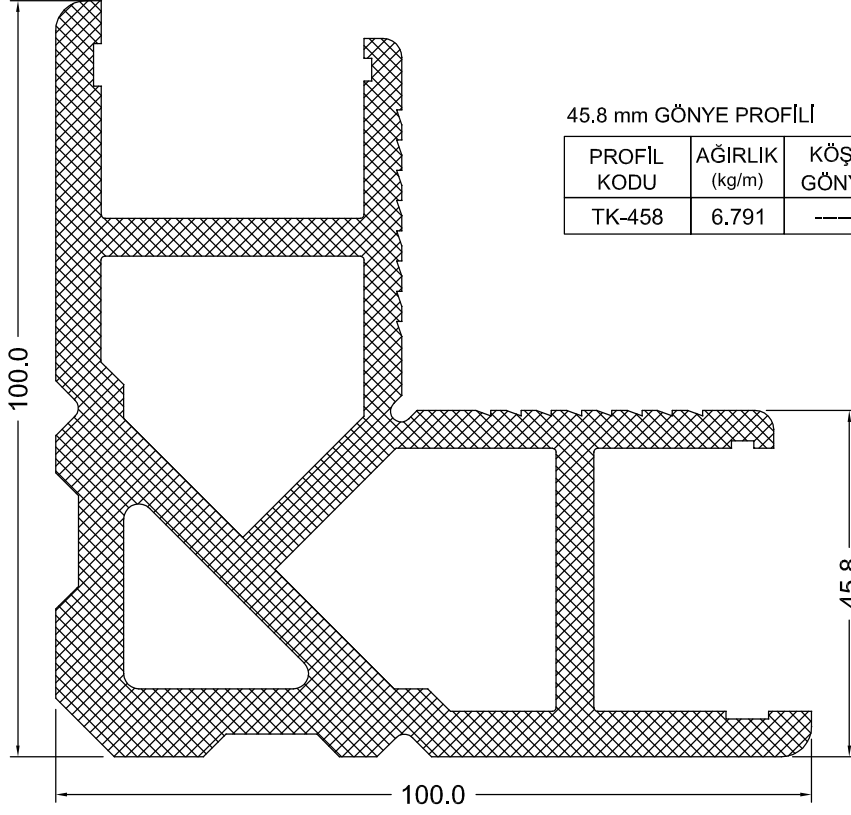

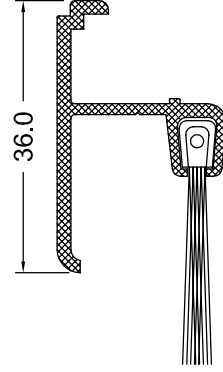

SW ZIVANA PROFİLİ

PROFİL KODU	AĞIRLIK (kg/m)
SW-530-00	0.344

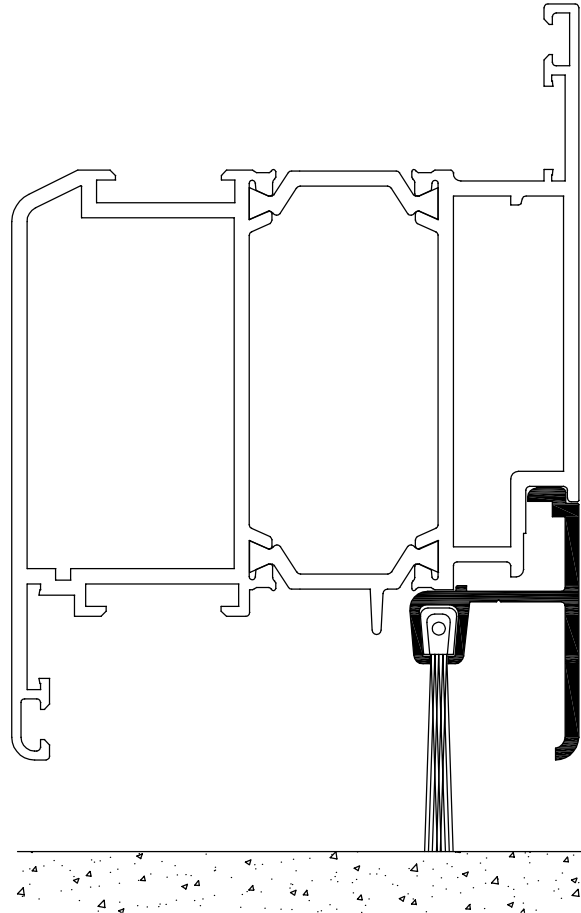

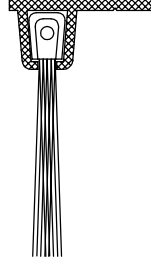

PROFİL KODU	AĞIRLIK (kg/m)
SW-531-00	0,135

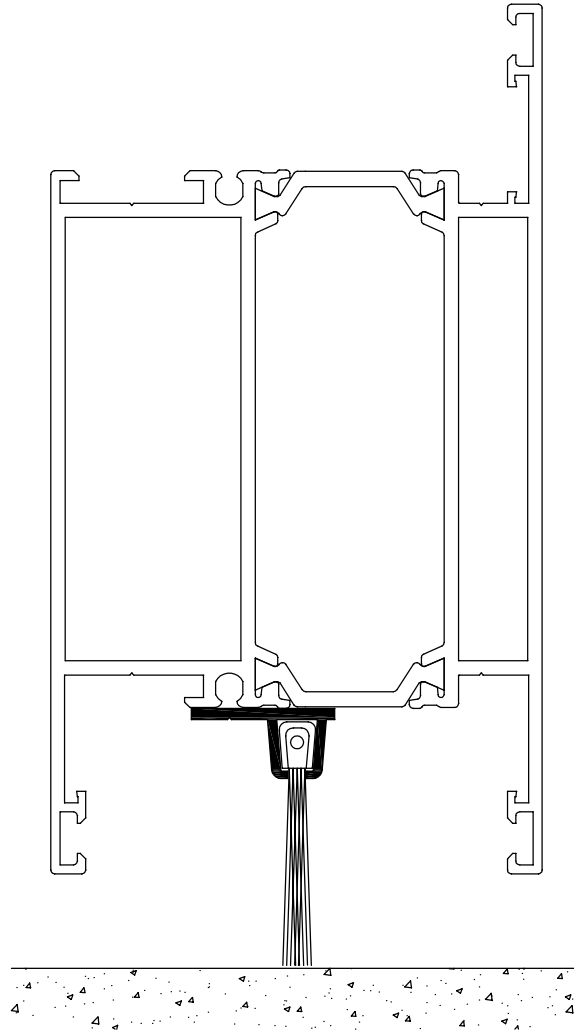

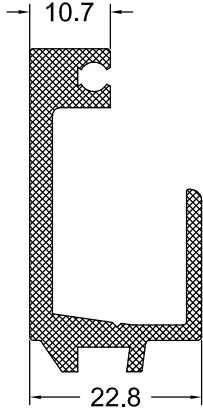

SW ZIVANA PROFİLİ

PROFİL KODU	AĞIRLIK (kg/m)
SW-541-00	0.742

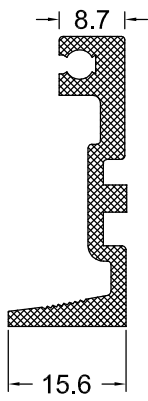

SW ZIVANA PROFİLİ

PROFİL KODU	AĞIRLIK (kg/m)
SW-542-00	0.499

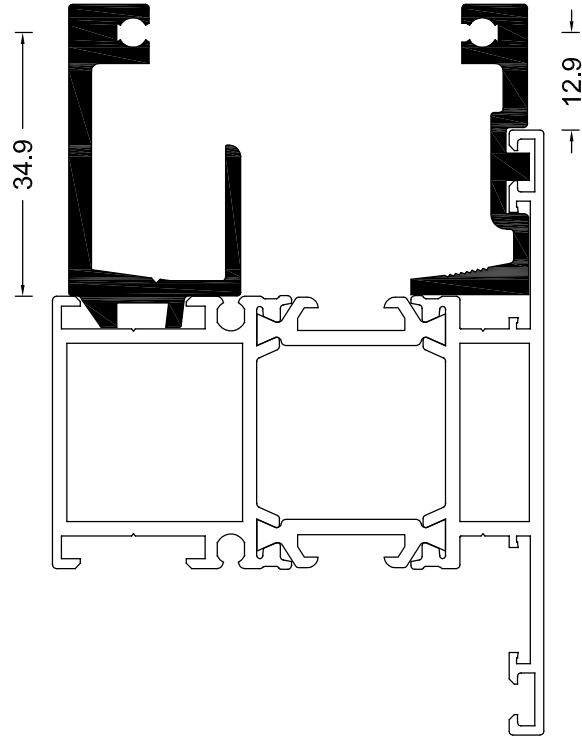

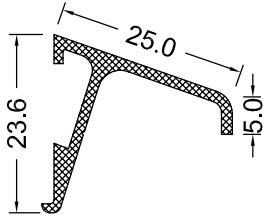

SW ZIVANA PROFİLİ

PROFİL KODU	AĞIRLIK (kg/m)
SW-532-00	0.217kg/m

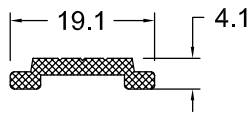
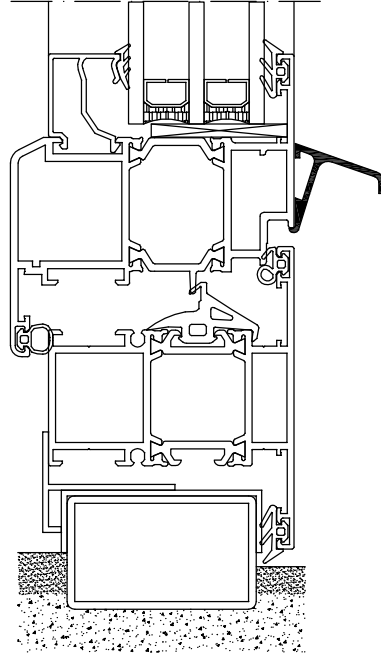

PROFİL KODU	AĞIRLIK (kg/m)
SW-533-00	0.124

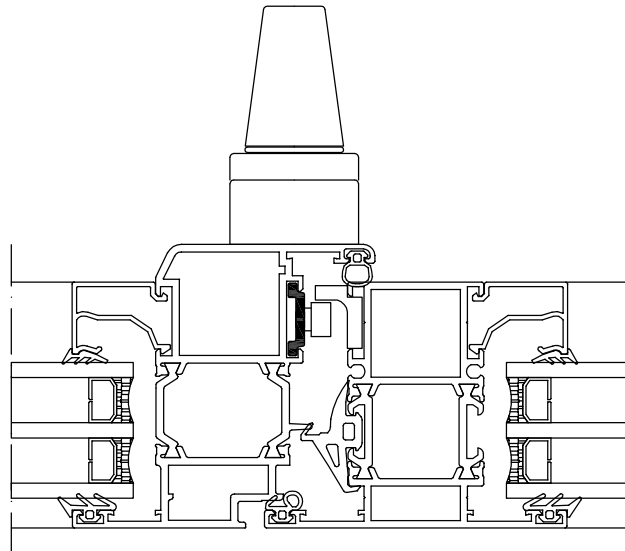

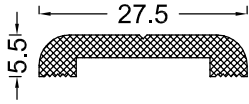

PROFİL KODU	AĞIRLIK (kg/m)
SW-548-00	0.268

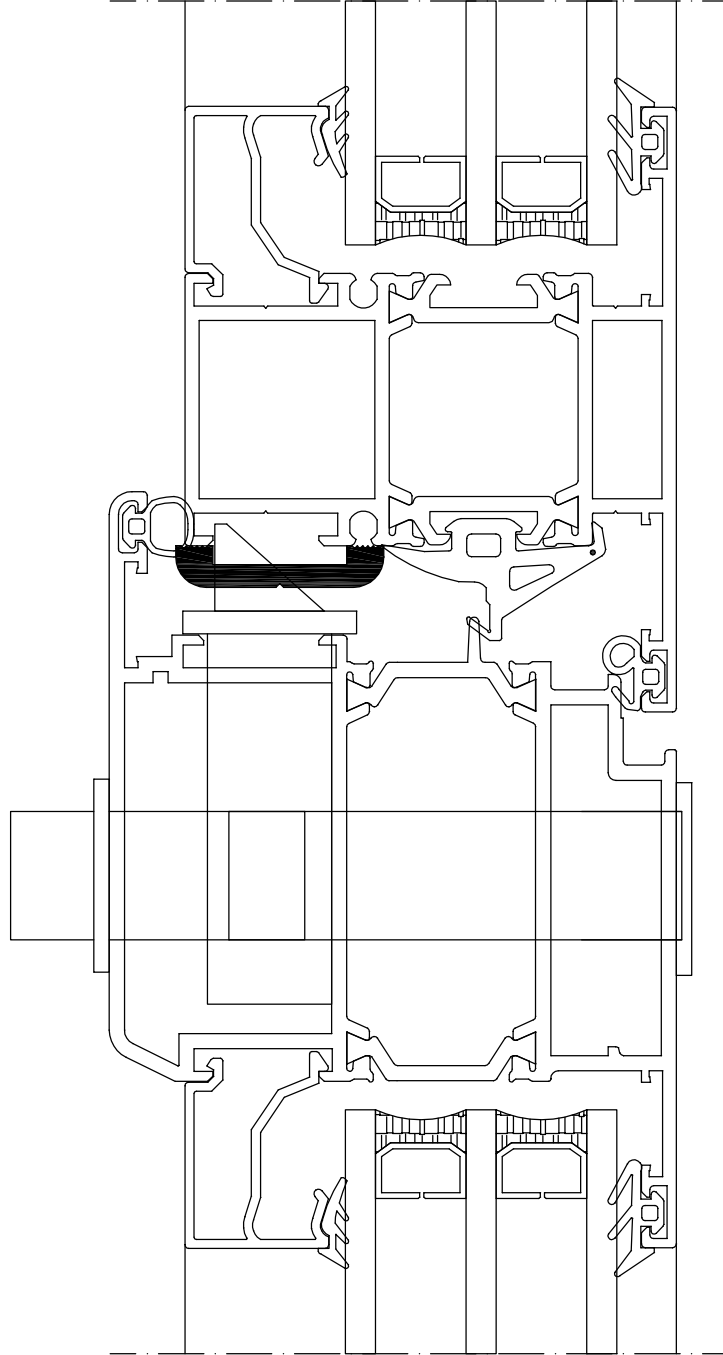

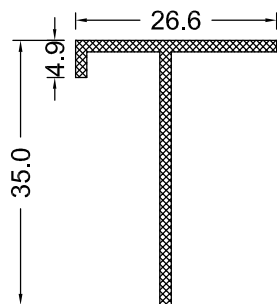

PROFİL KODU	AĞIRLIK (kg/m)
SW-901-15	0.257

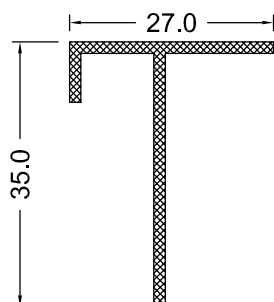

PROFİL KODU	AĞIRLIK (kg/m)
SW-902-15	0.271

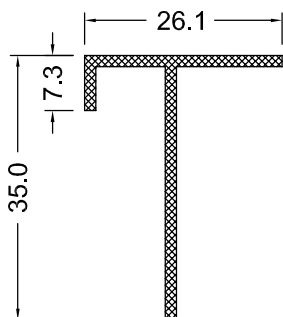

PROFİL KODU	AĞIRLIK (kg/m)
SW-903-15	0.265

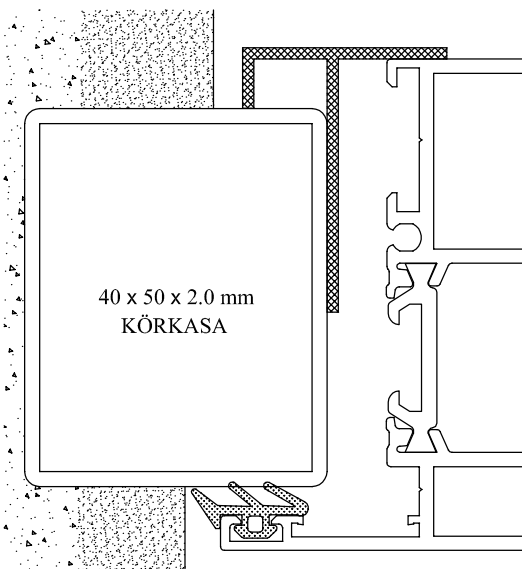
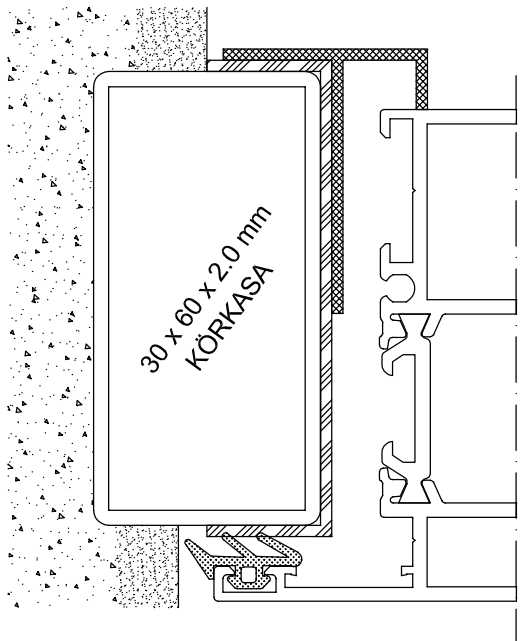
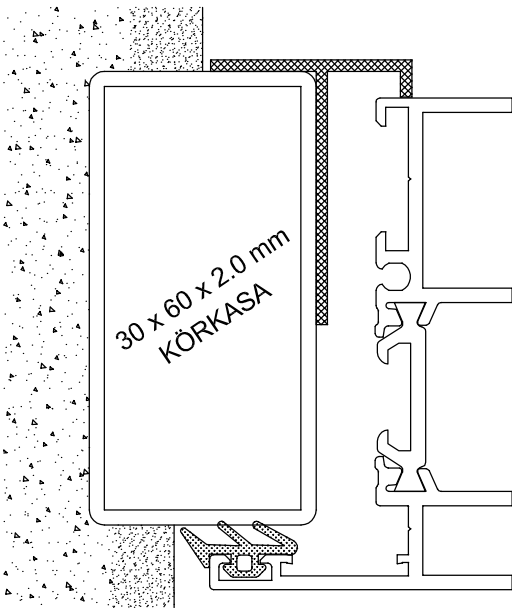
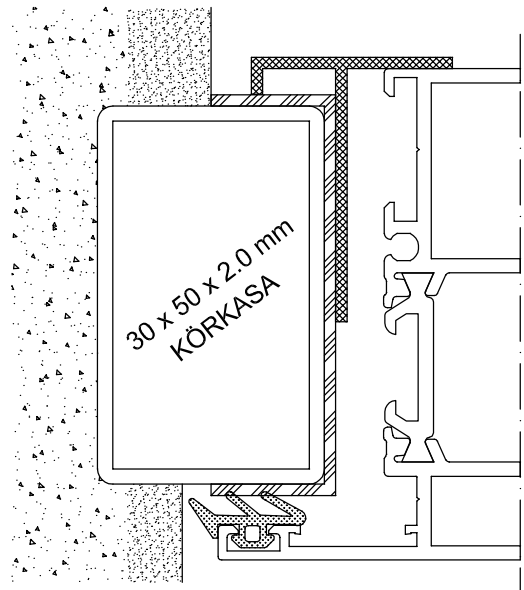
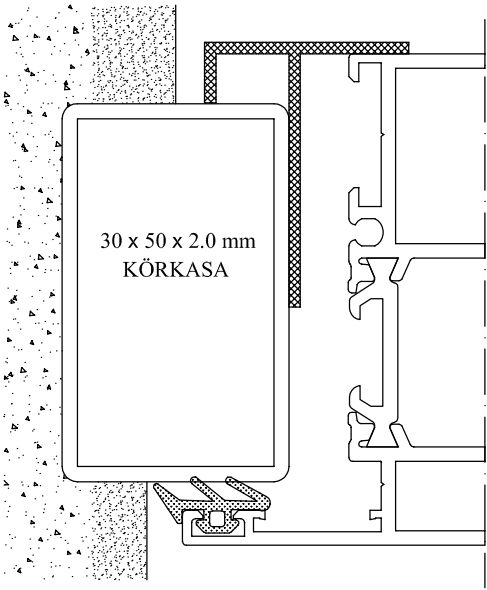

BRUT CAM BOŞLUĞU

SW-441-12

0.341 Kg/m

SW-441-15

0.420 Kg/m

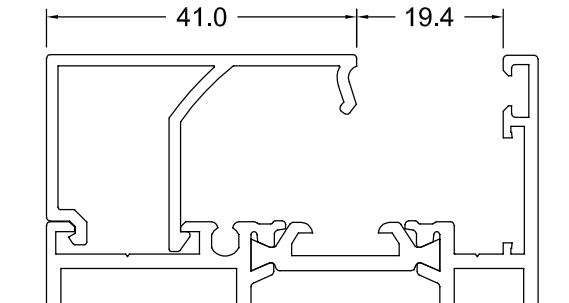
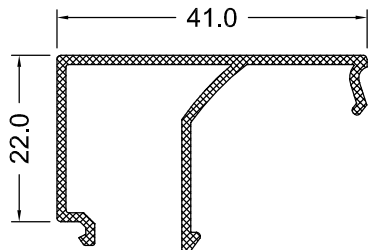

SW-439-12

0.336 Kg/m

SW-439-15

0.412 Kg/m

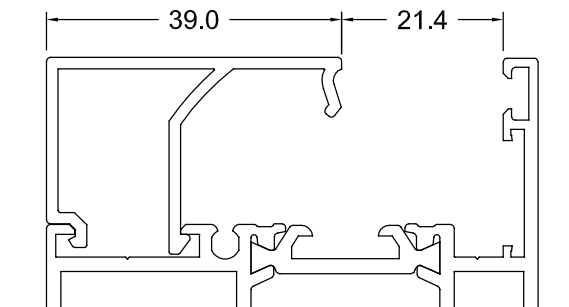
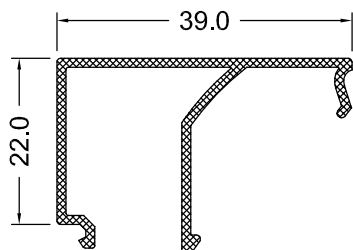

SW-437-12

0.328 Kg/m

SW-437-15

0.404 Kg/m

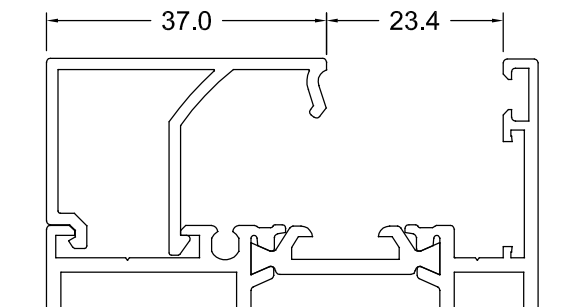
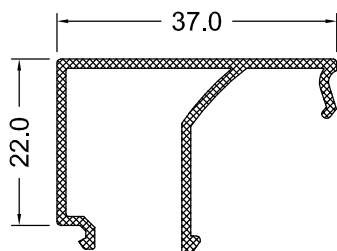

SW-435-12

0.322 Kg/m

SW-435-15

0.396 Kg/m

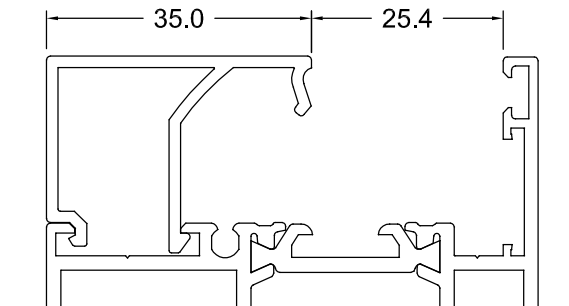
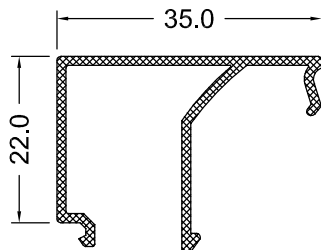

SW-433-12

0.314 Kg/m

SW-433-15

0.387 Kg/m

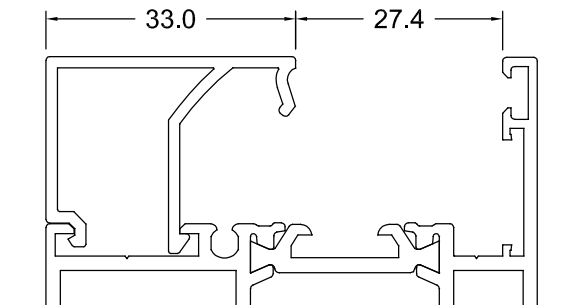
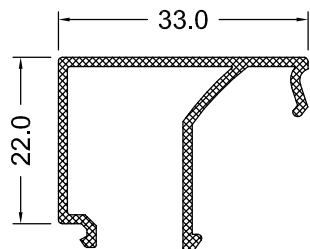

SW-431-12

0.309 Kg/m

SW-431-15

0.379 Kg/m

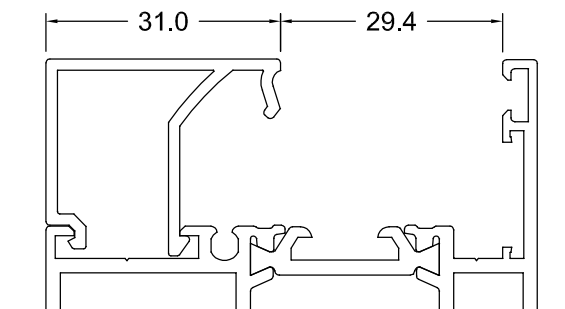
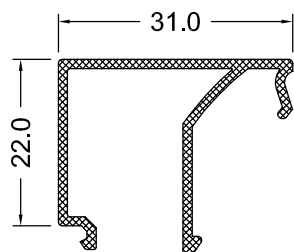

SW-429-12

0.303 Kg/m

SW-429-15

0.371 Kg/m

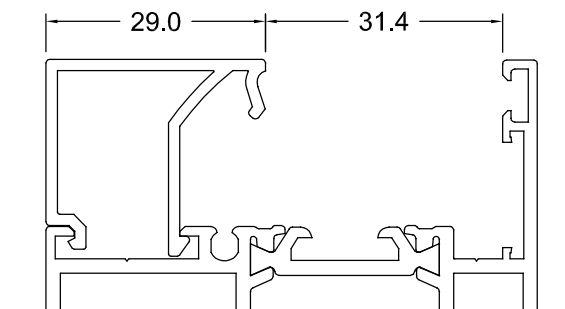
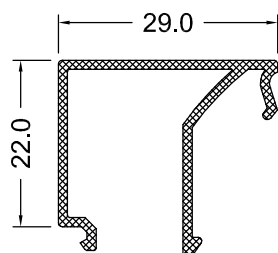

SW-427-12

0.295 Kg/m

SW-427-15

0.357 Kg/m

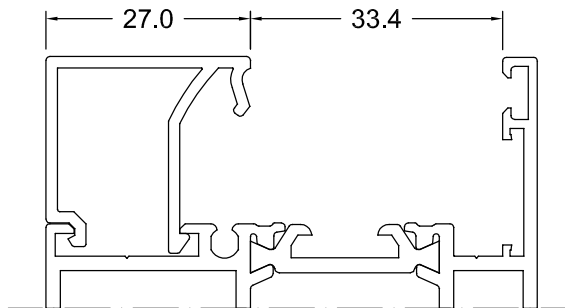
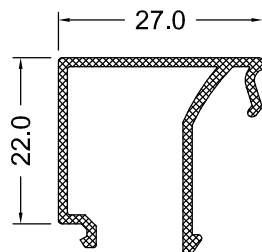

SW-425-12

0.290 Kg/m

SW-425-15

0.347 Kg/m

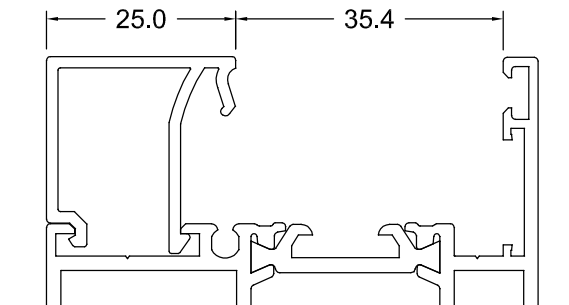
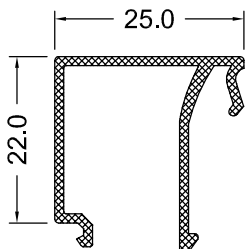

SW-423-12

0.279 Kg/m

SW-423-15

0.341 Kg/m

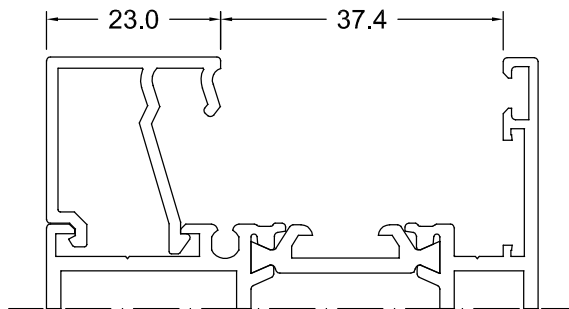
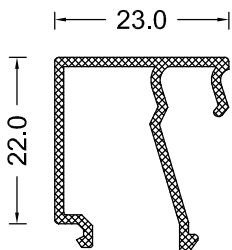

SW-421-12

0.271 Kg/m

SW-421-15

0.333 Kg/m

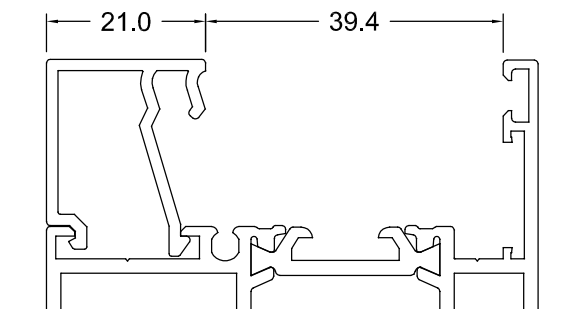
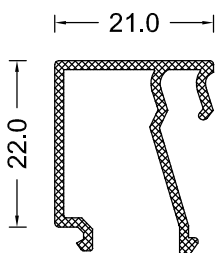

SW-419-12

0.274 Kg/m

SW-419-15

0.336 Kg/m

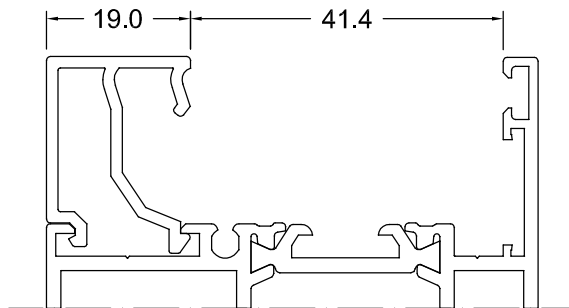
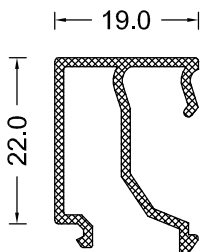

SW-417-12

0.268 Kg/m

SW-417-15

0.328 Kg/m

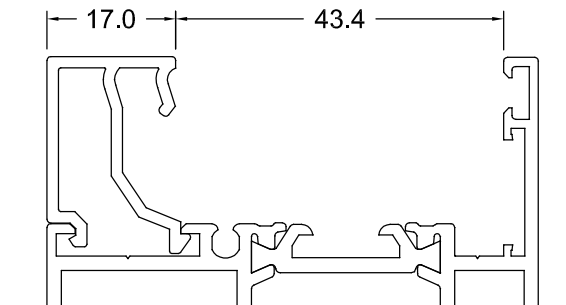
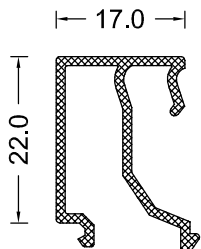

SW-415-12

0.236 Kg/m

SW-415-15

0.290 Kg/m

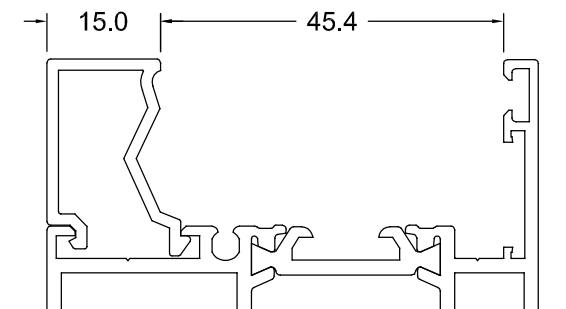
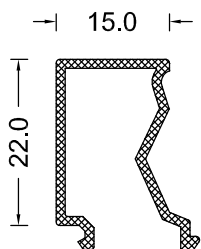

SW-413-12

0.230 Kg/m

SW-413-15

0.282 Kg/m

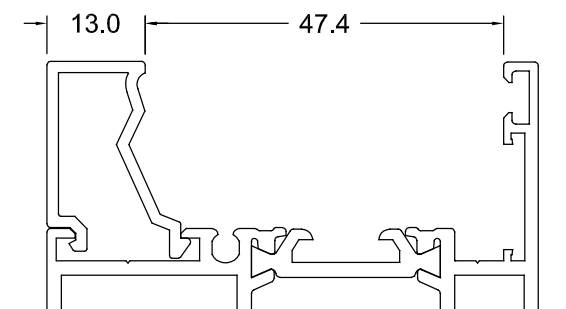
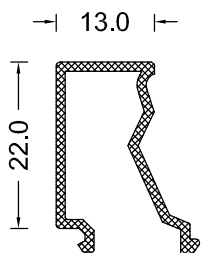

SW-410-12

0.225 Kg/m

SW-410-15

0.276 Kg/m

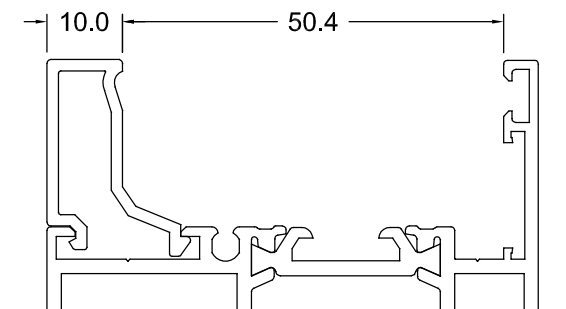
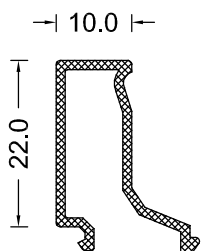

PROFİL KODU	AĞIRLIK (kg/m)
SW-405-14	0.198

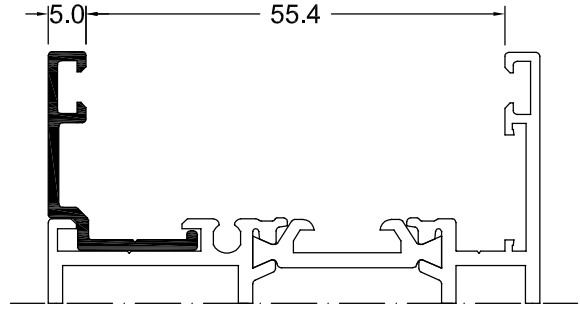
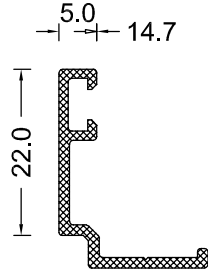

NET CAM BOŞLUĞU

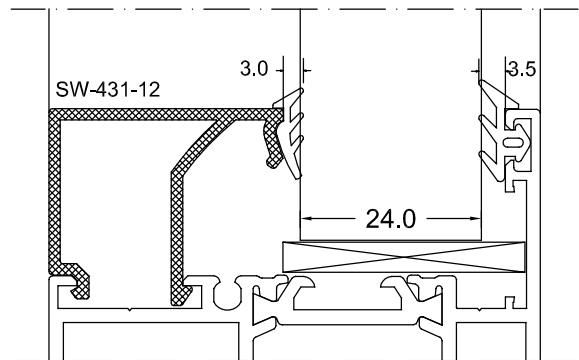
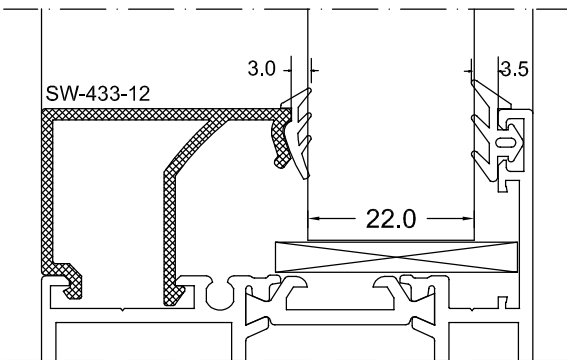
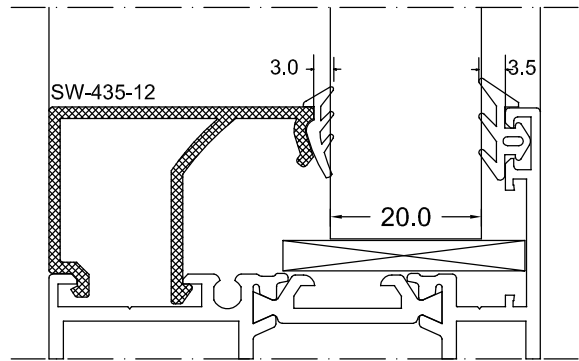
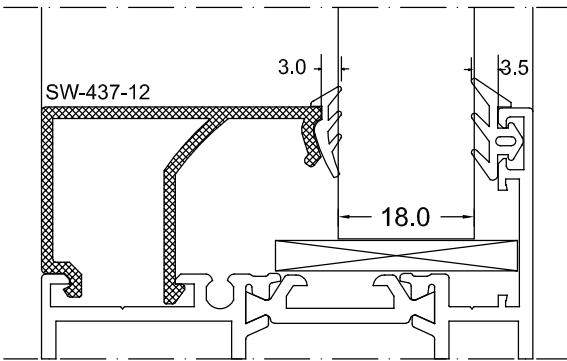
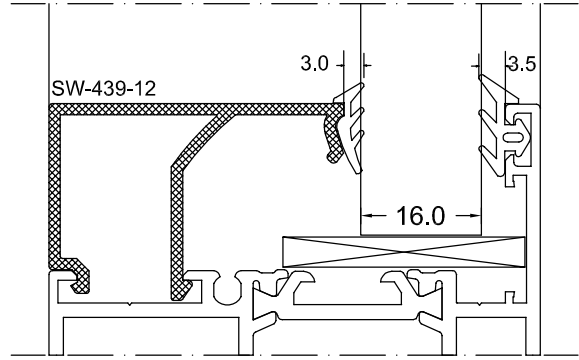
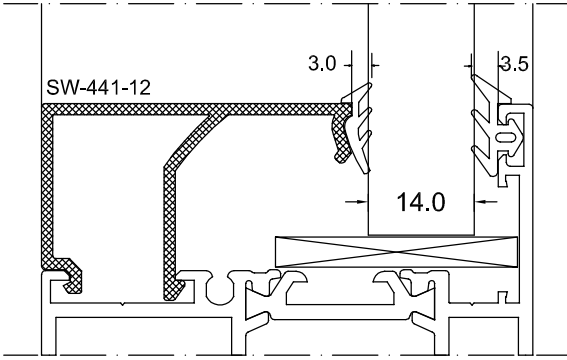

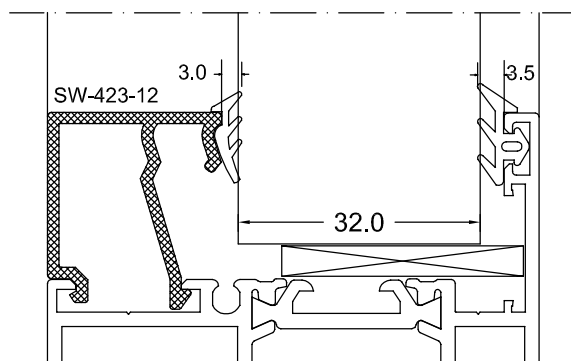
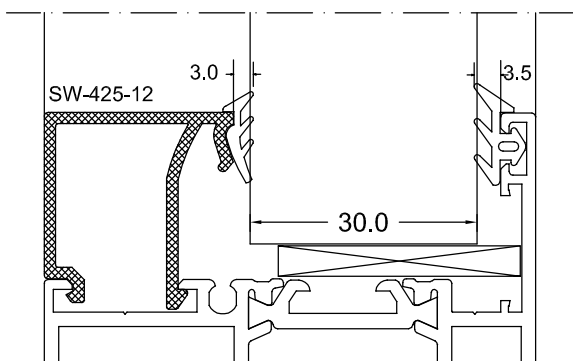
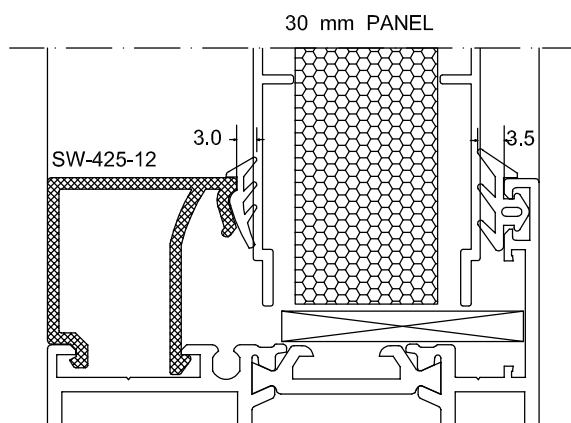
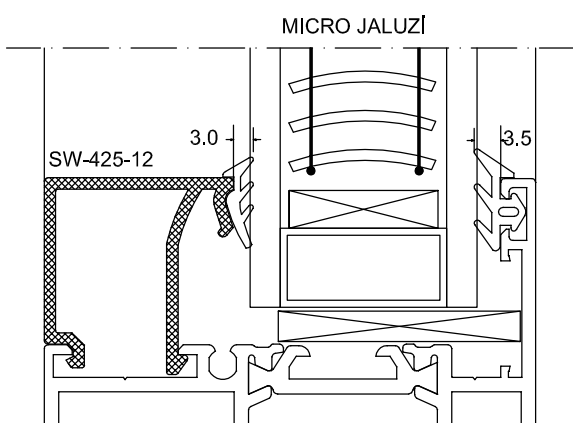
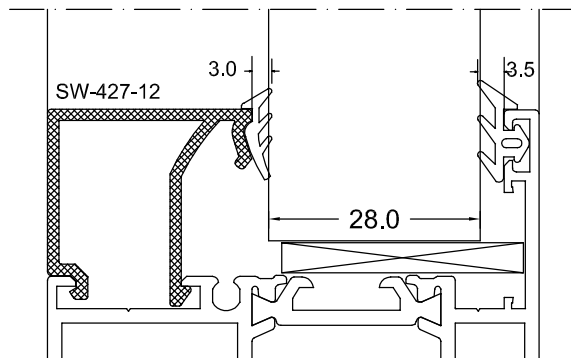
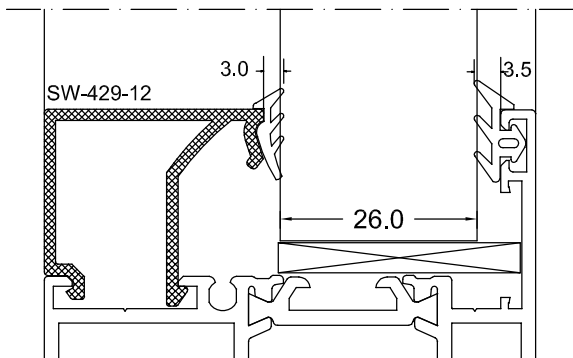

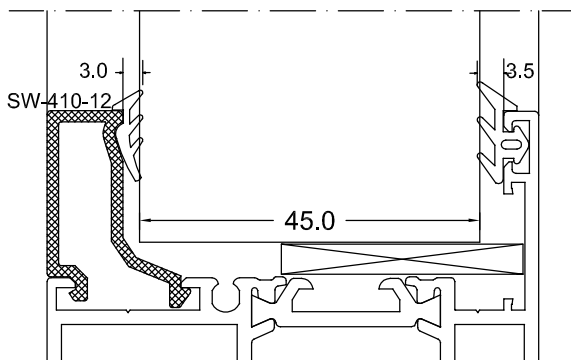
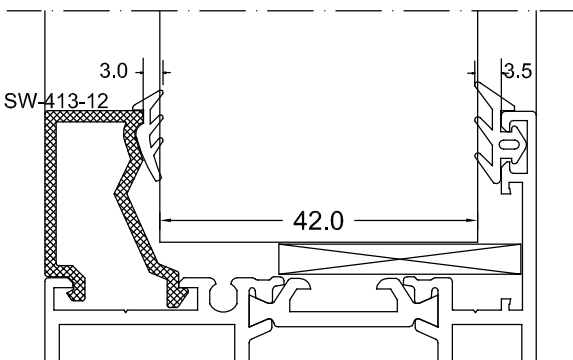
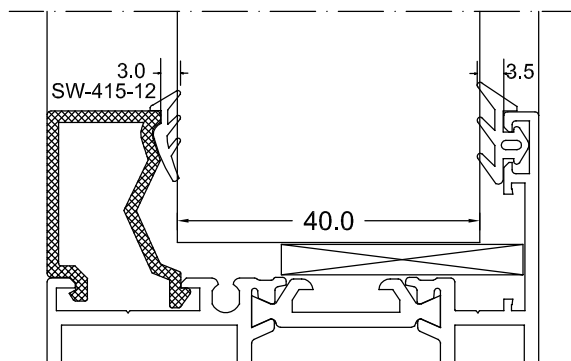
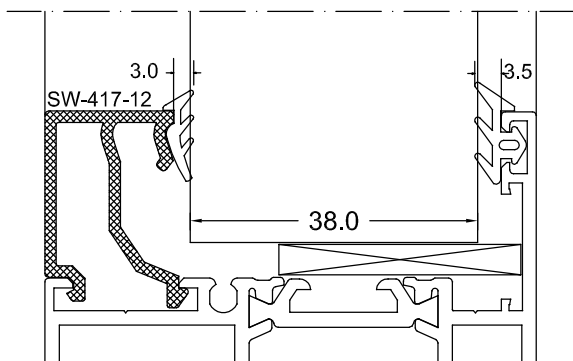
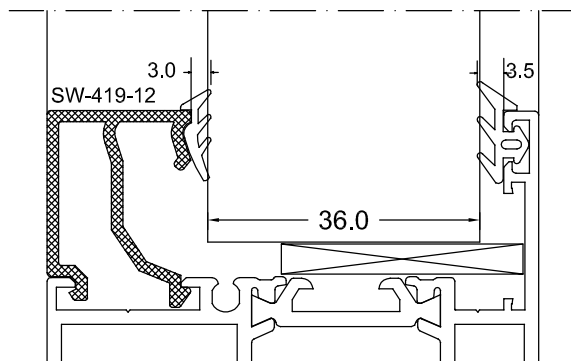
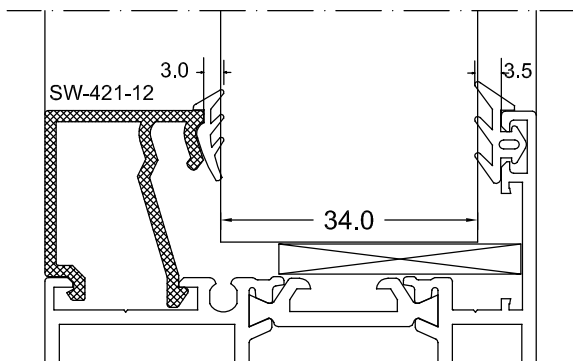

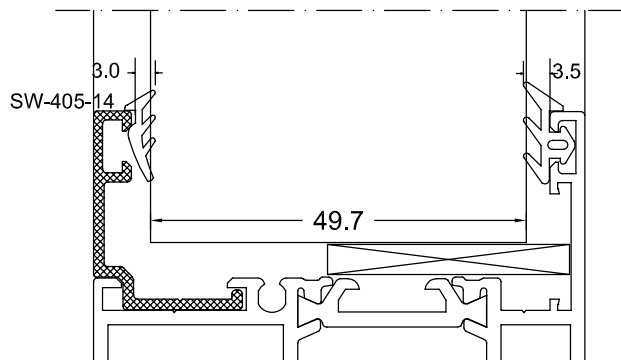





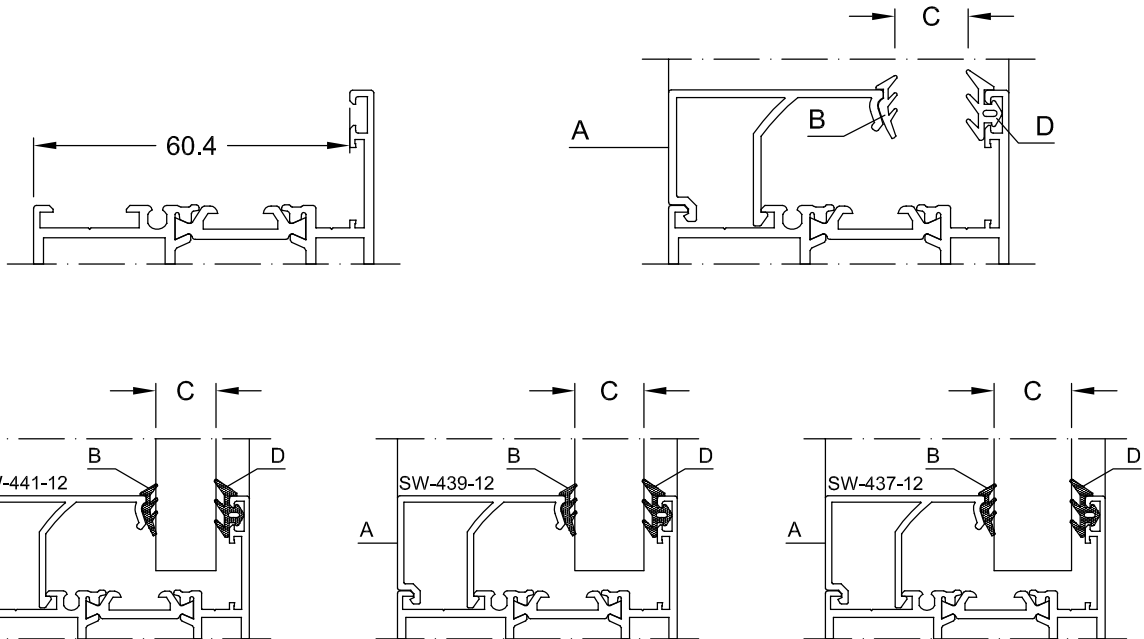

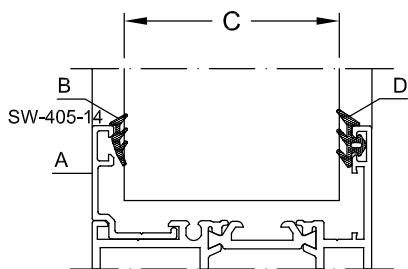
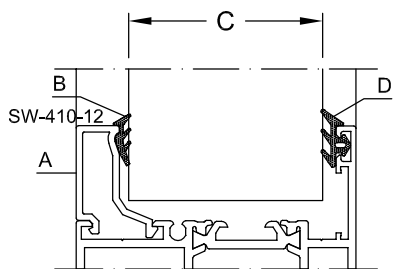
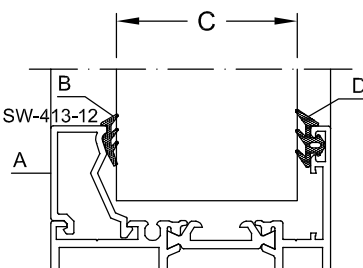
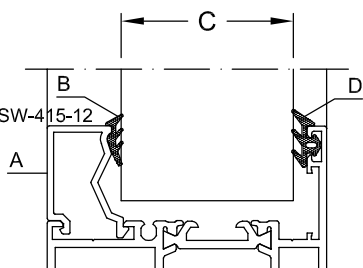
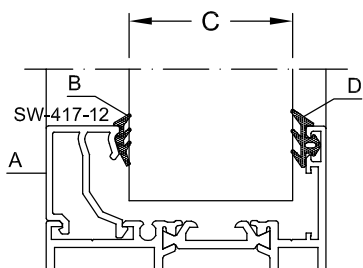
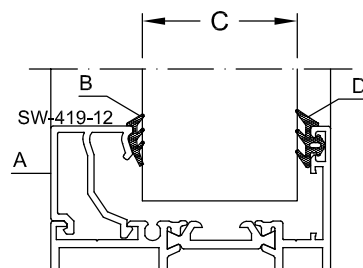
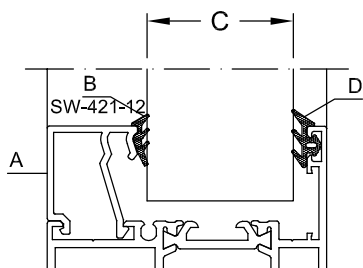
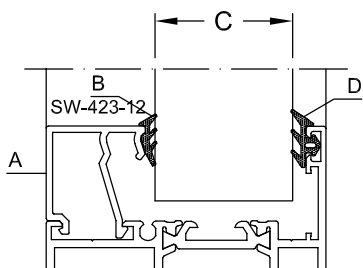
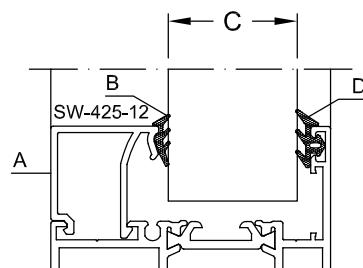
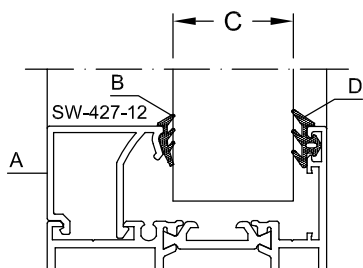
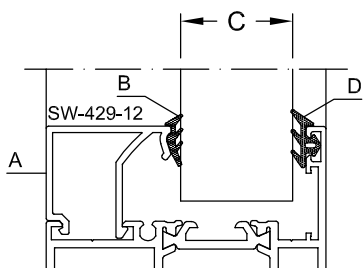
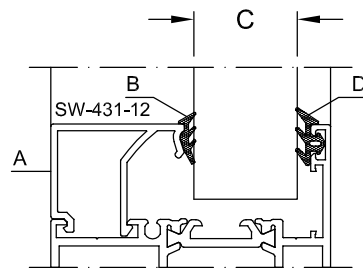
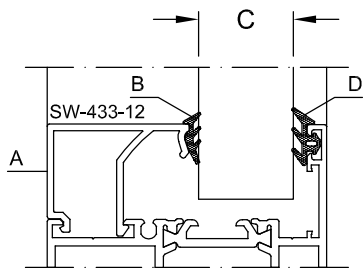
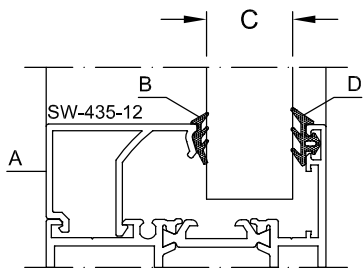

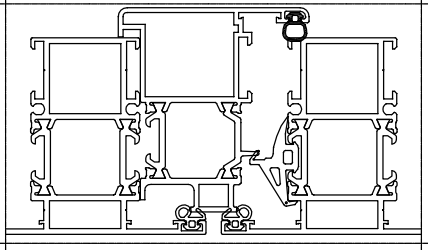

CAM KALINLIĞINA GÖRE FİTİL TAYİNİ

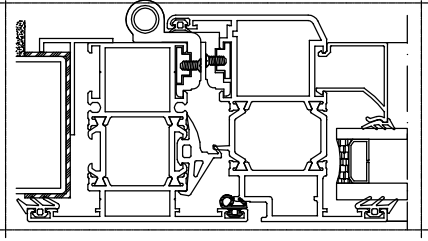
A CAM ÇITASI	B İÇ CAM FİTİLİ	C CAM KALINLIĞI	D DIŞ CAM FİTİLİ	TOPLAM BOŞLUK
SW-441-12	EPD 05	14 mm	EPD 04	60.4 mm
SW-439-12	EPD 05	16 mm	EPD 04	
SW-437-12	EPD 05	18 mm	EPD 04	
SW-435-12	EPD 05	20 mm	EPD 04	
SW-433-12	EPD 05	22 mm	EPD 04	
SW-431-12	EPD 05	24 mm	EPD 04	
SW-429-12	EPD 05	26 mm	EPD 04	
SW-427-12	EPD 05	28 mm	EPD 04	
SW-425-12	EPD 05	30 mm	EPD 04	
SW-423-12	EPD 05	32 mm <td EPD 04		
SW-421-12	EPD 05	34 mm	EPD 04	
SW-419-12	EPD 05	36 mm	EPD 04	
SW-417-12	EPD 05	38 mm	EPD 04	
SW-415-12	EPD 05	40 mm	EPD 04	
SW-413-12	EPD 05	42 mm	EPD 04	
SW-410-12	EPD 05	45 mm	EPD 04	
SW-405-14	EPD 05	50 mm	EPD 04	

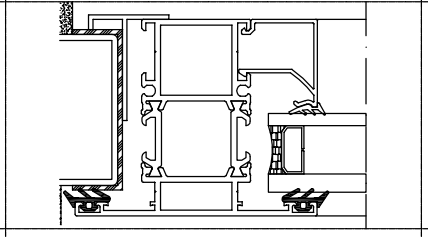

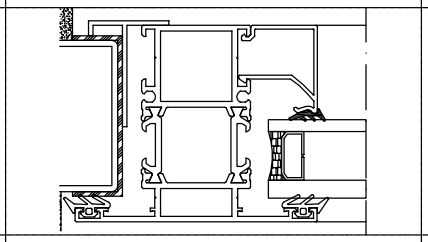
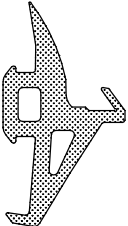
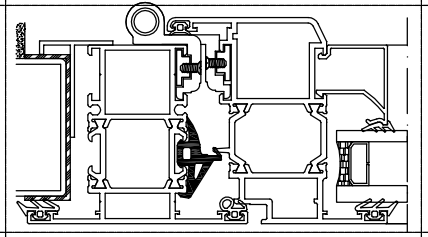

Fıtıl Kodu	Fıtıl Resmi	Teslimat Şekli	Montaj Çizimi
<u>EPD 01</u>		1 KOLİ 380mt/13Kg 34gr/m	
<u>EPD 02</u>		1 KOLİ 350mt/15Kg 42gr/m	
<u>EPD 04</u>		1 KOLİ 270mt/16Kg 59gr/m	
<u>EPD 05</u>		1 KOLİ 340mt/15Kg 44gr/m	
<u>EPD 07</u>		1 KOLİ 70mt/13Kg 185gr/m	

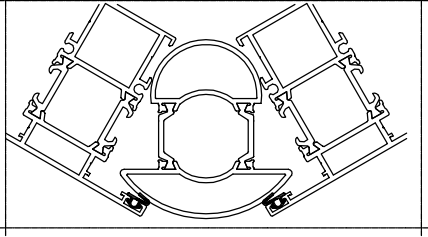
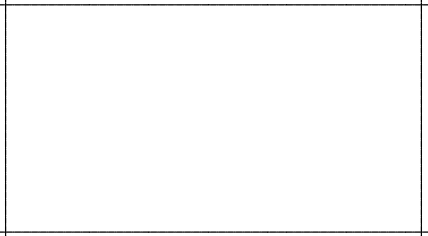
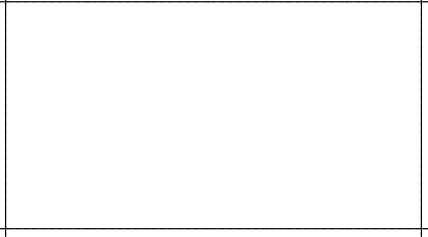
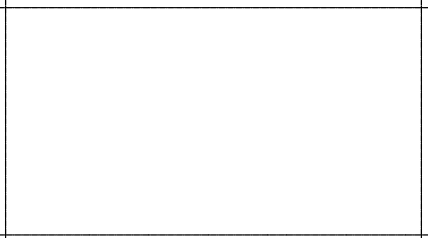
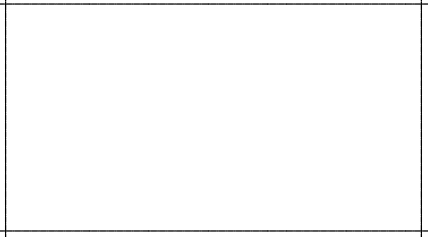
Ftil Kodu	Ftil Resmi	Teslimat Őekli	Montaj izimi
<u>EPC 71</u>		1 KOLİ 260mt/13Kg 50gr/m	
			
			
			
			



ALUFOUR

YALITIMLI DOĞRAMA SİSTEMİ



ALUFOUR

YALITIMLI DOĞRAMA SİSTEMİ

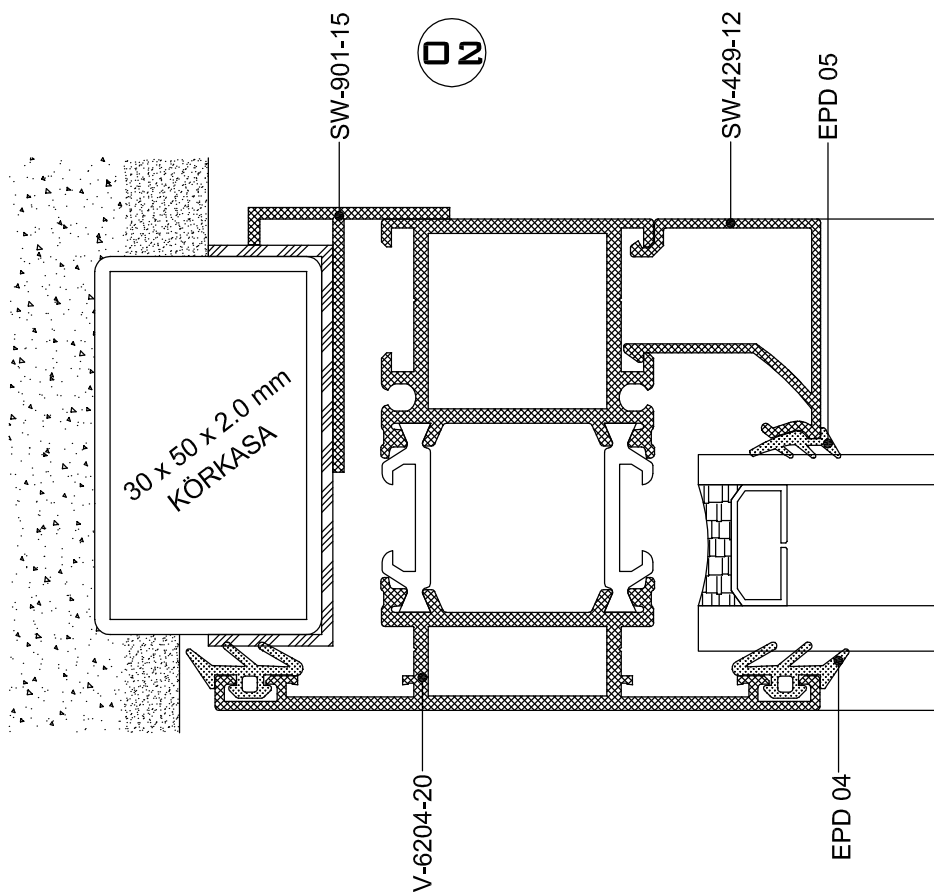
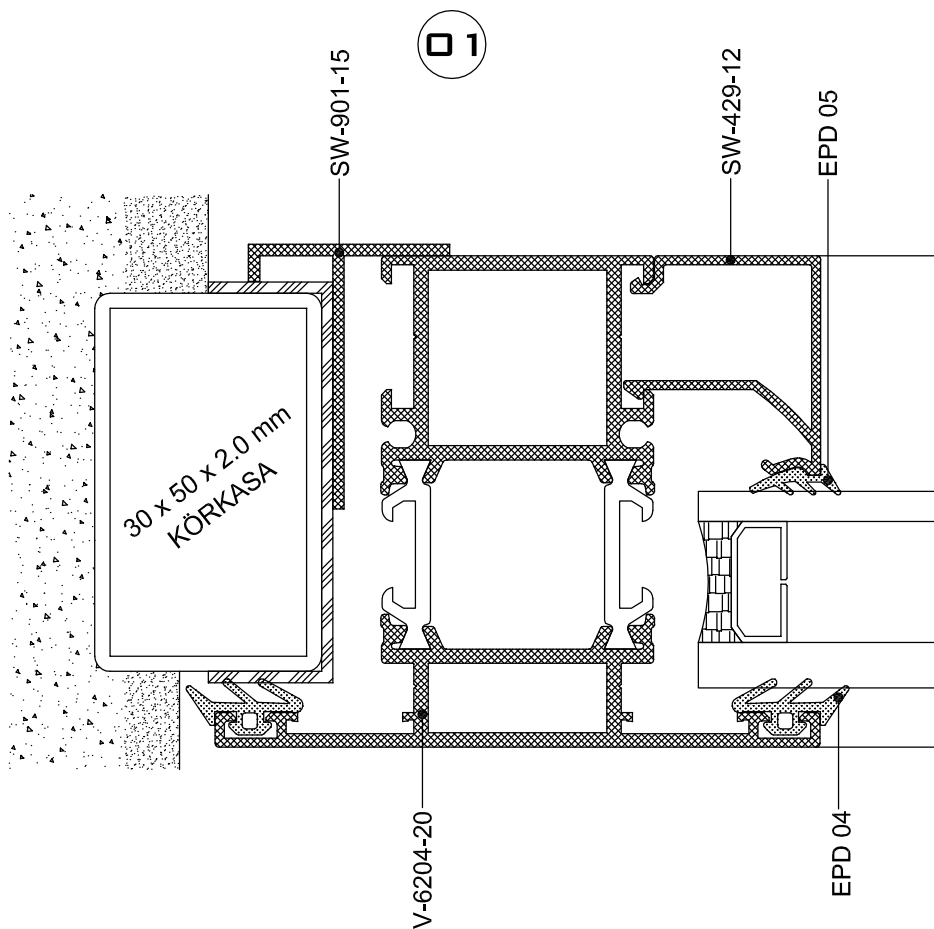

03

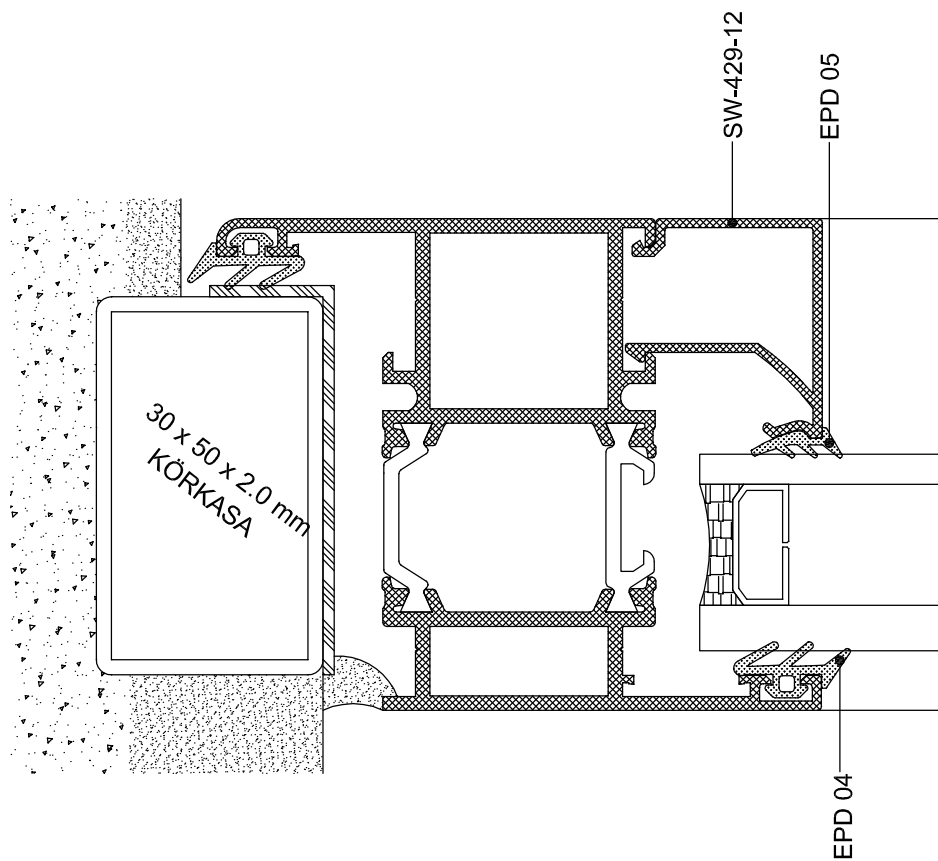

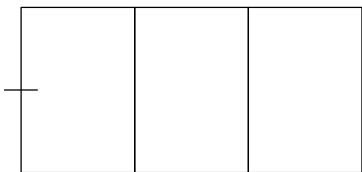

04

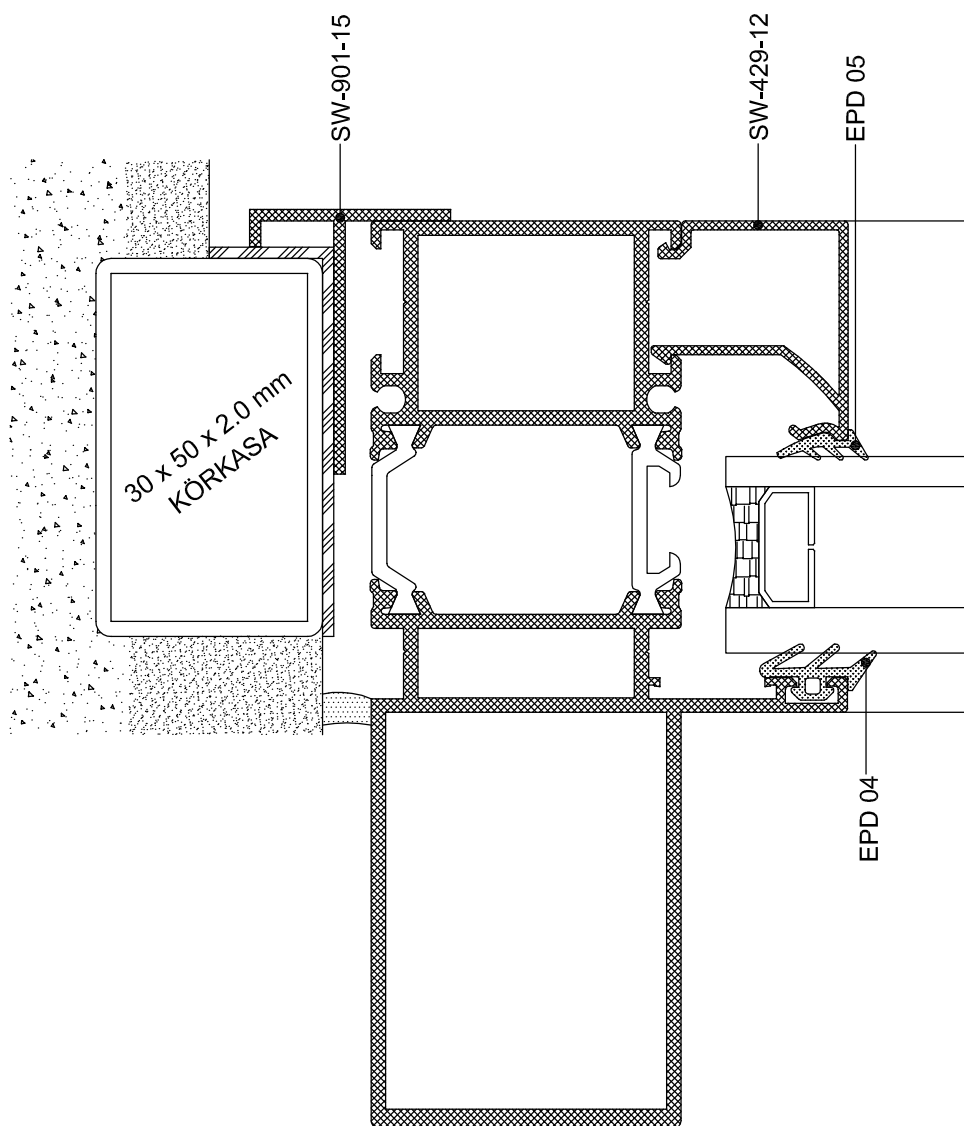

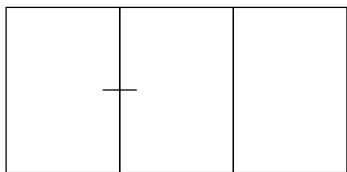

05

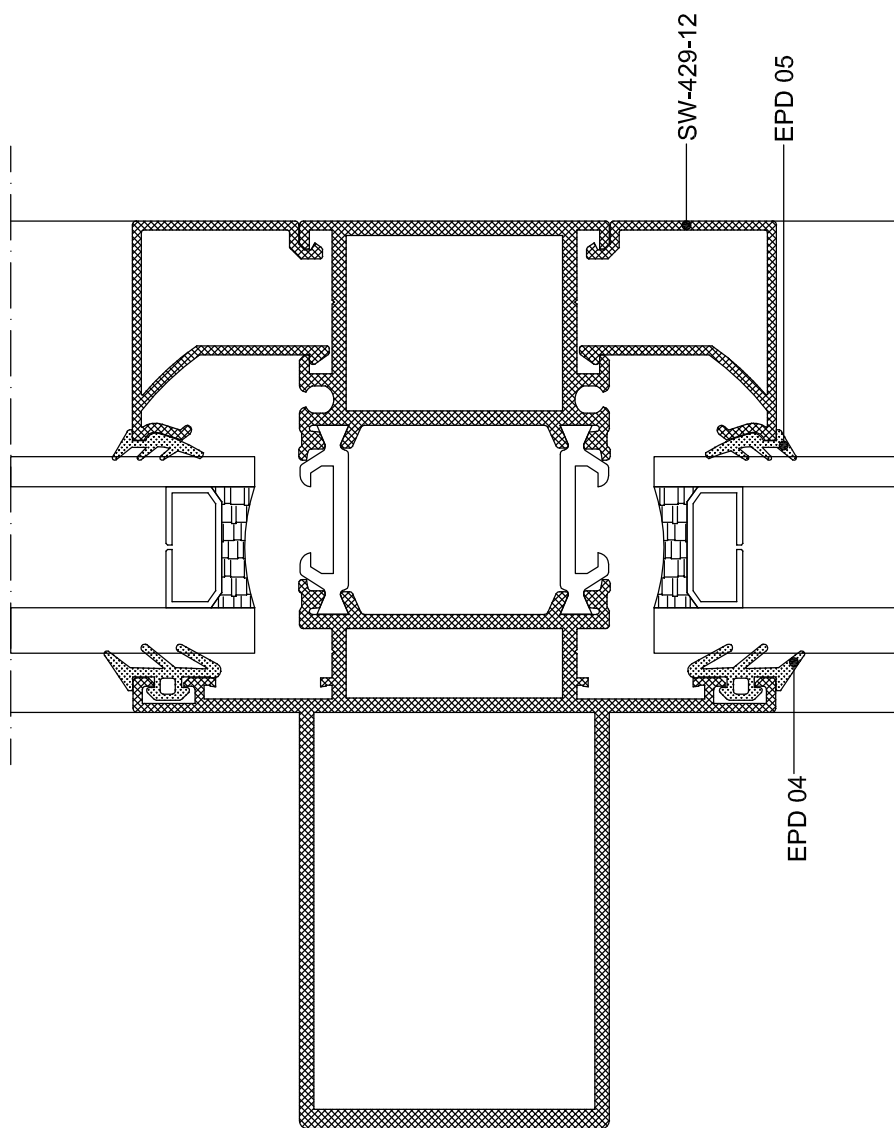

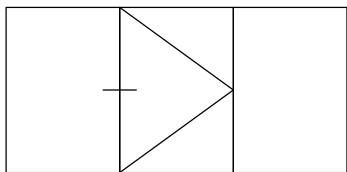

06

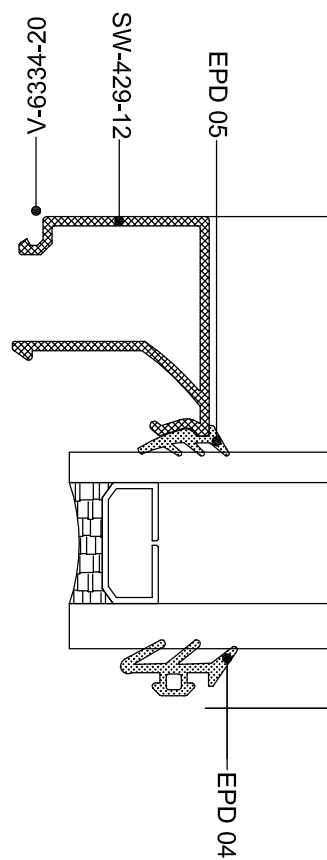
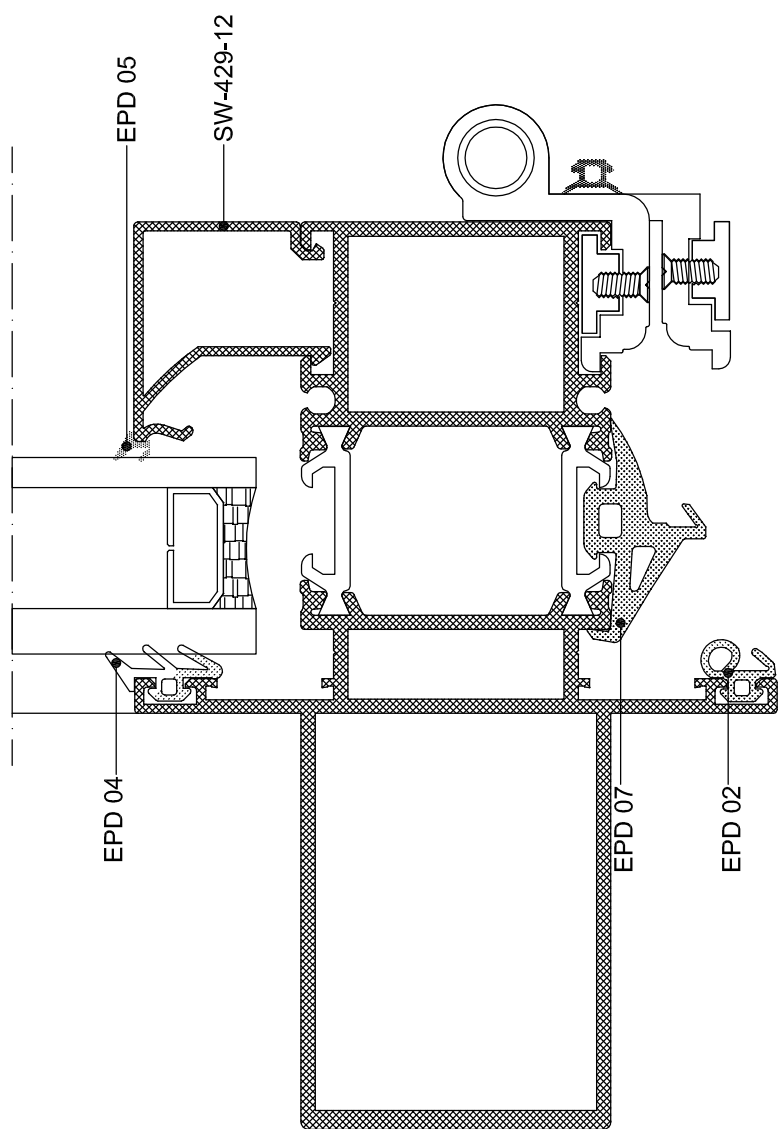

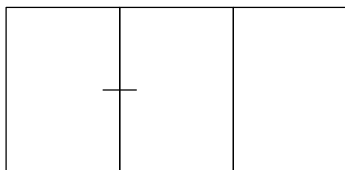

07

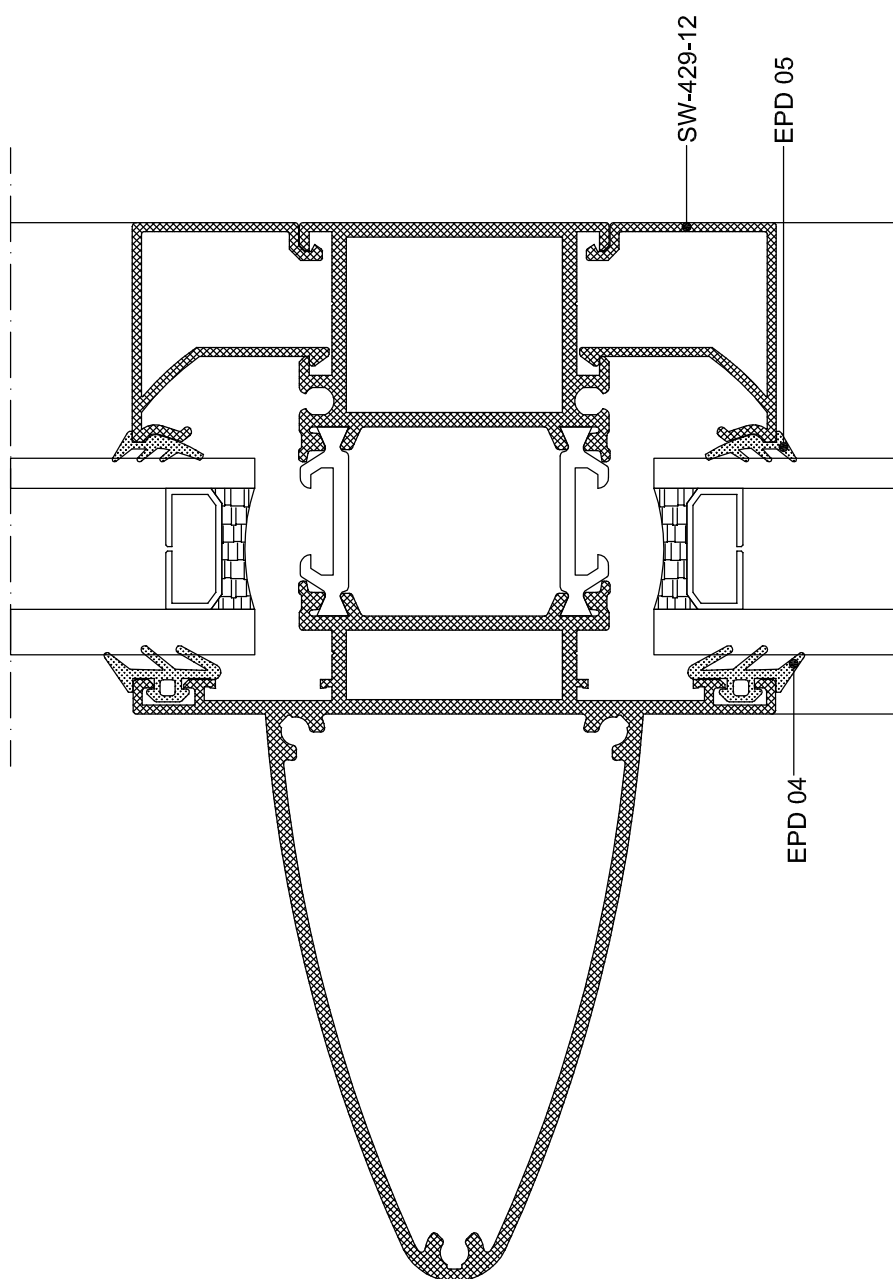

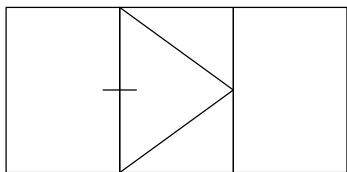

08

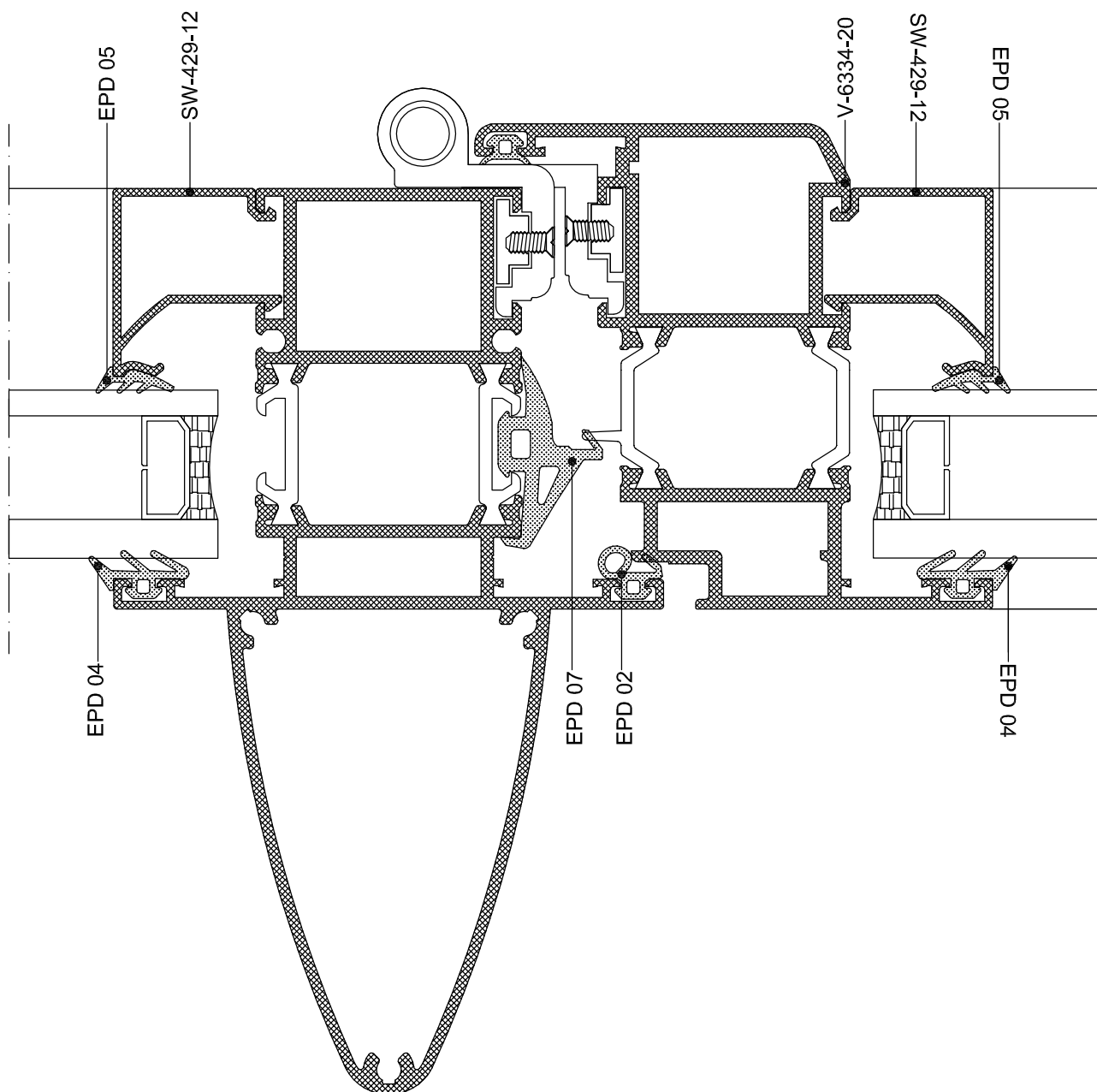

09

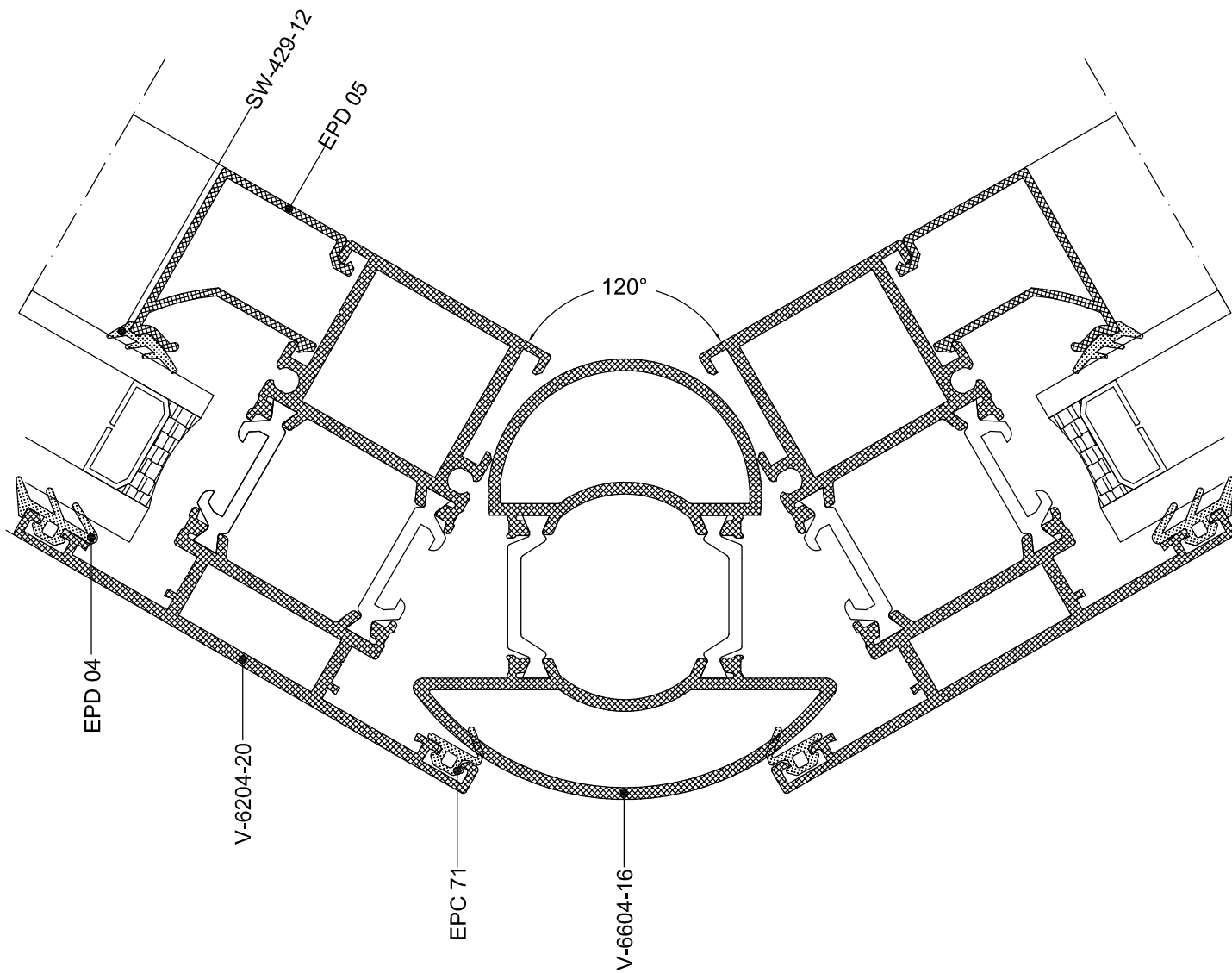

10

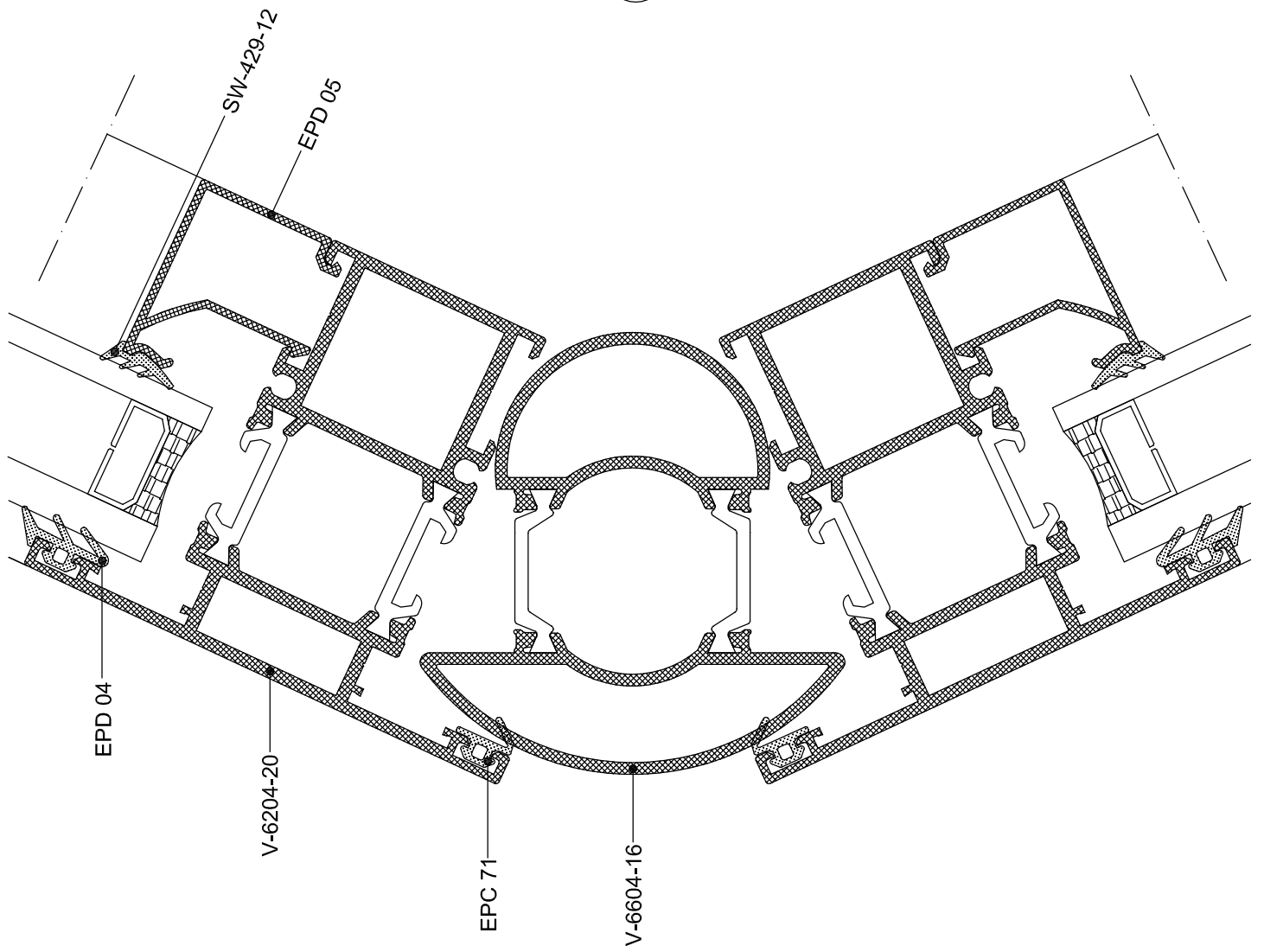

11

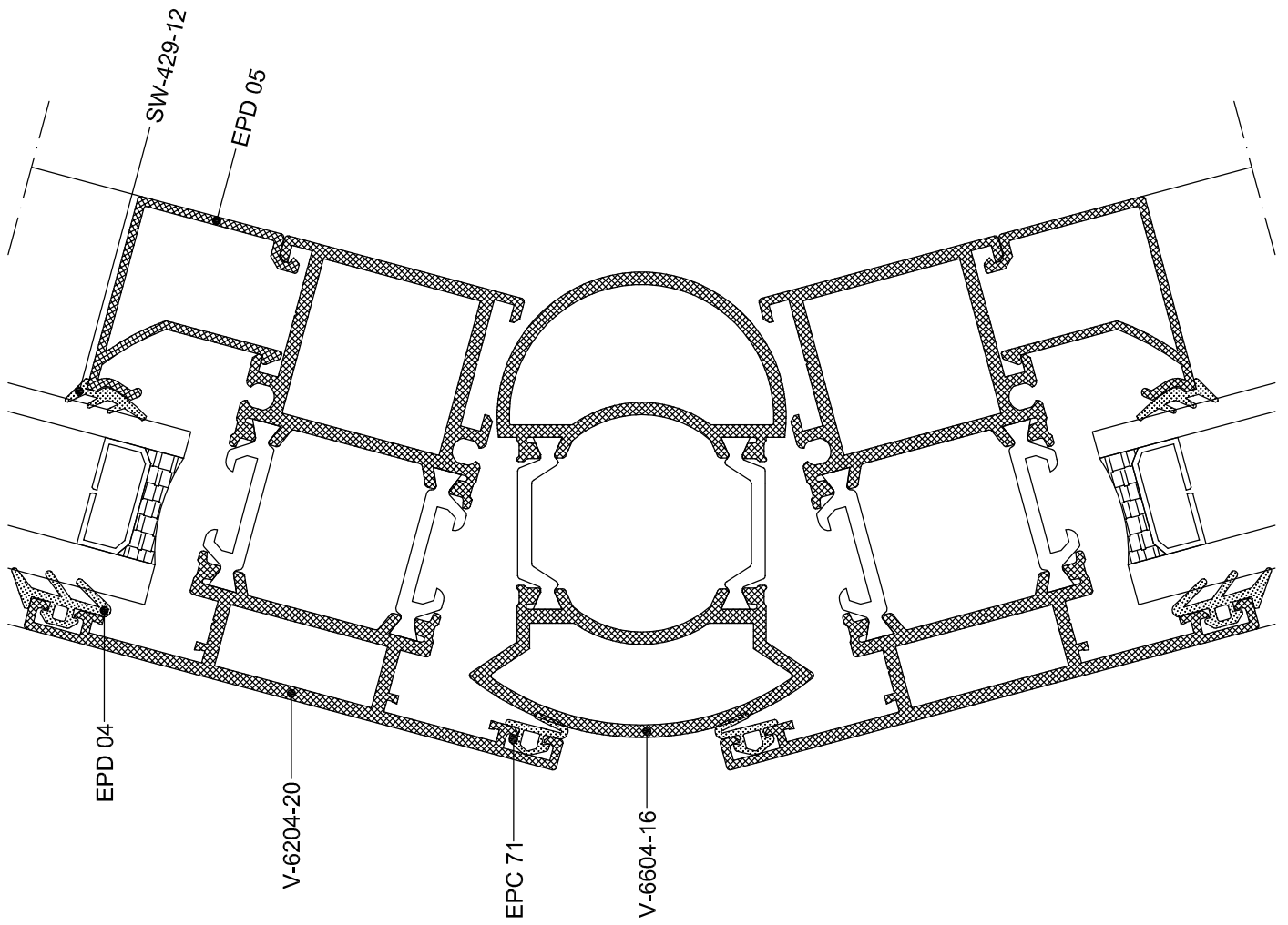

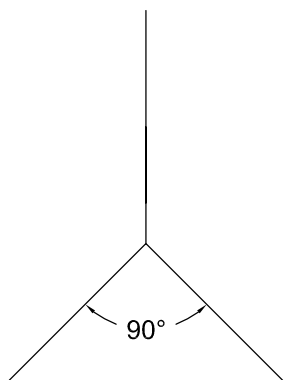

12

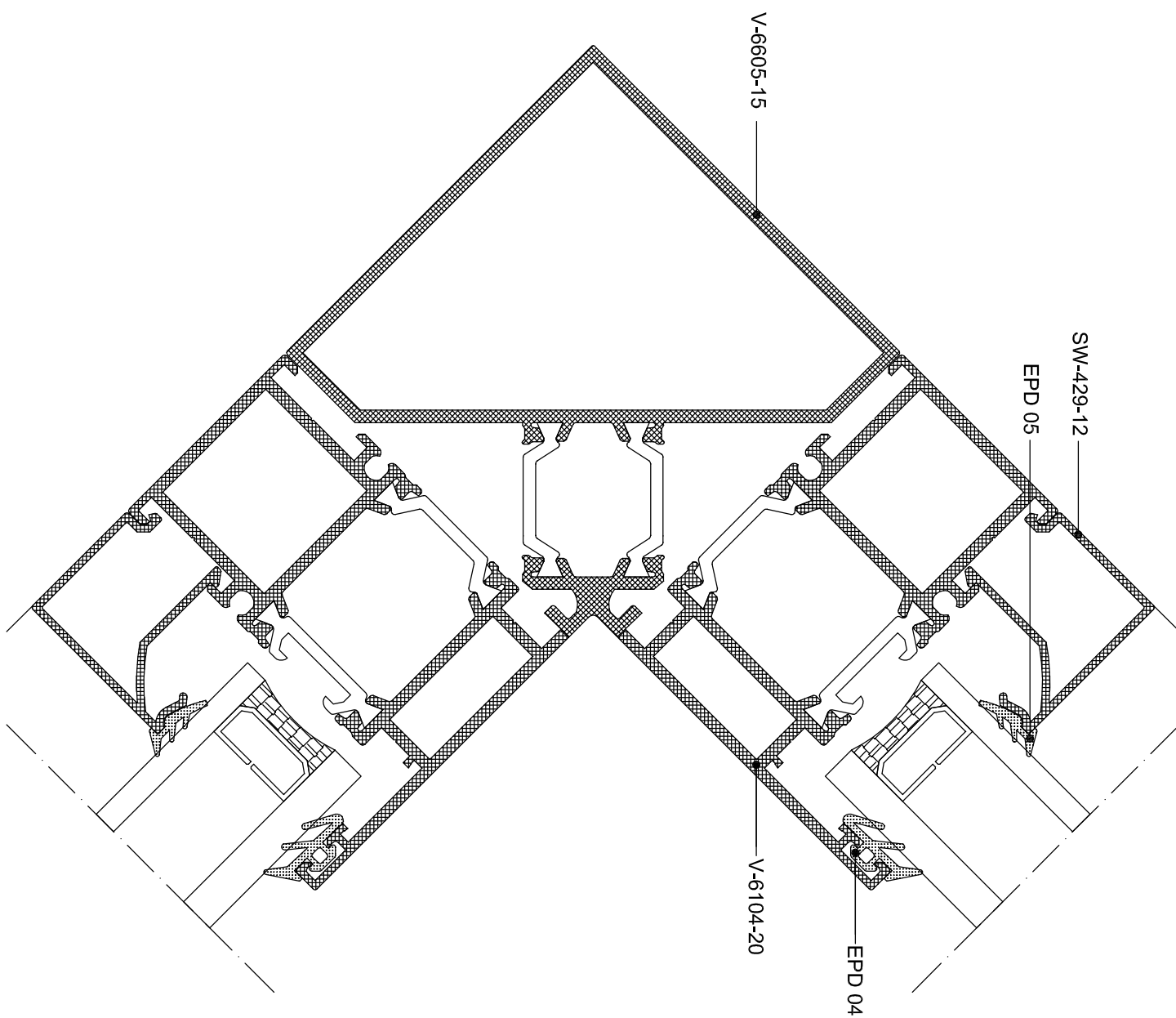

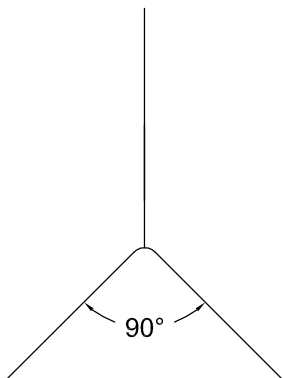

13

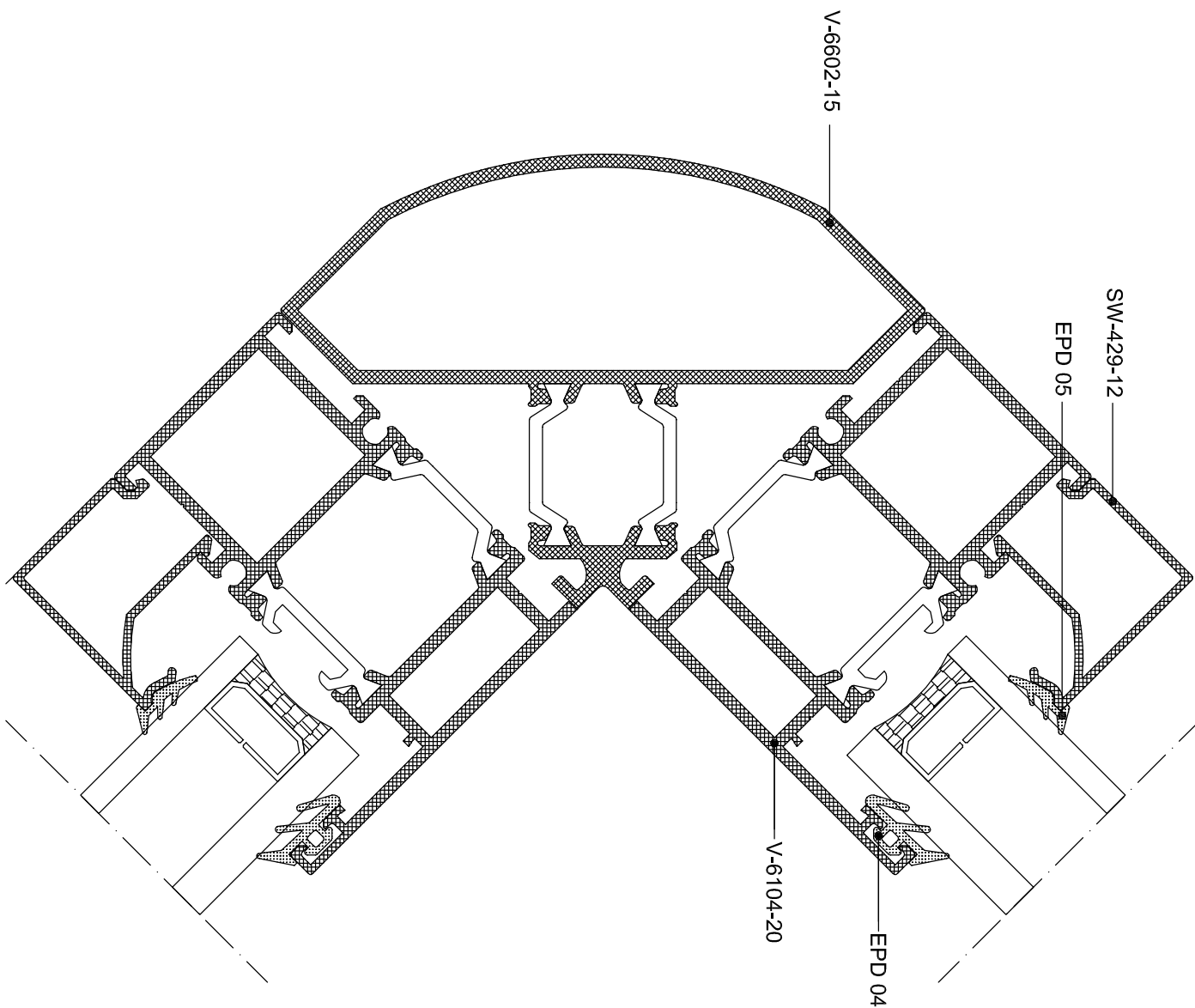

14

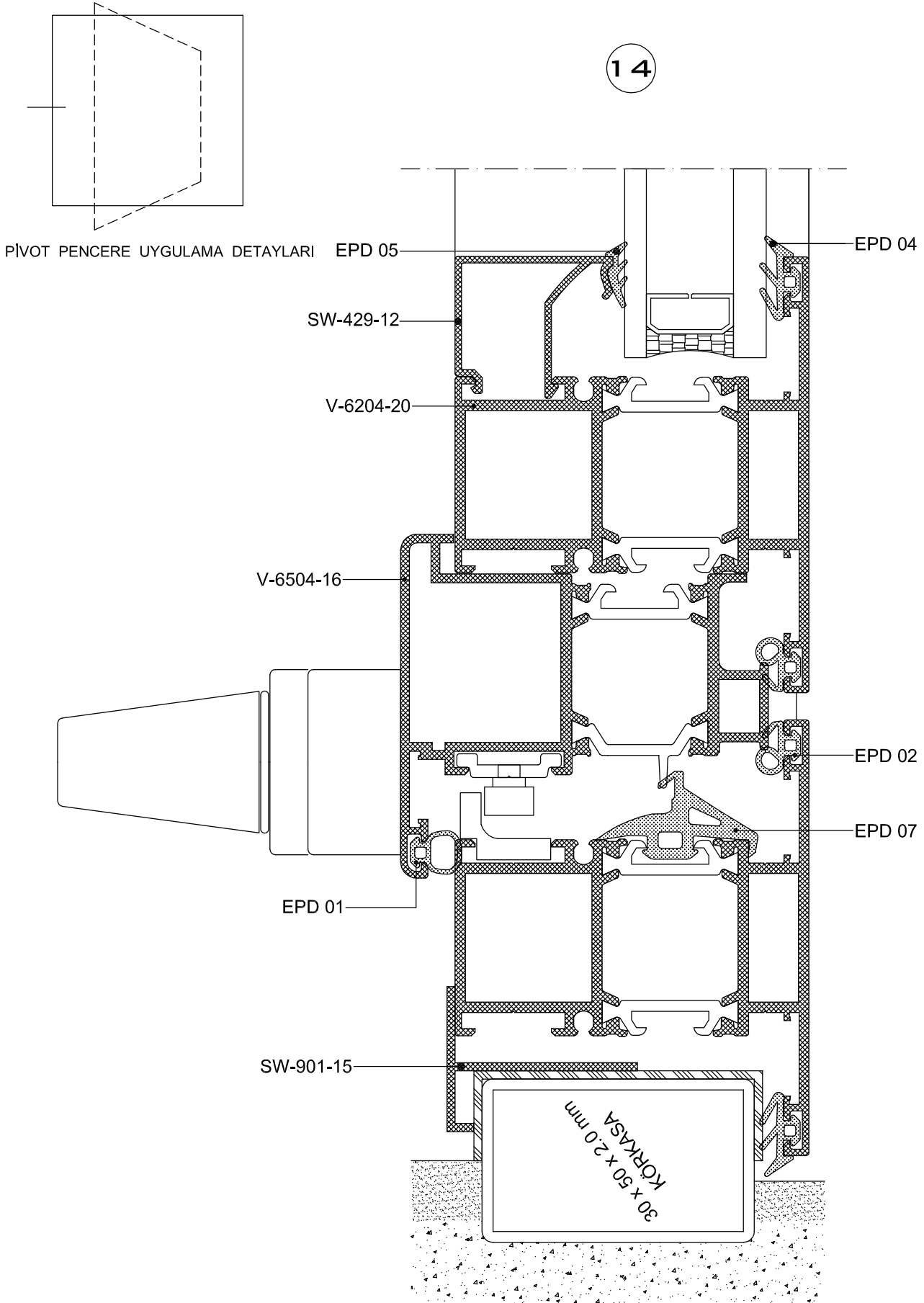

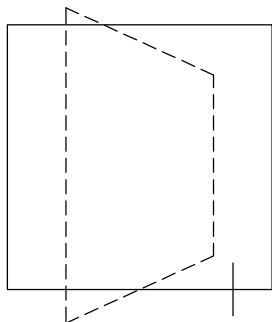

15

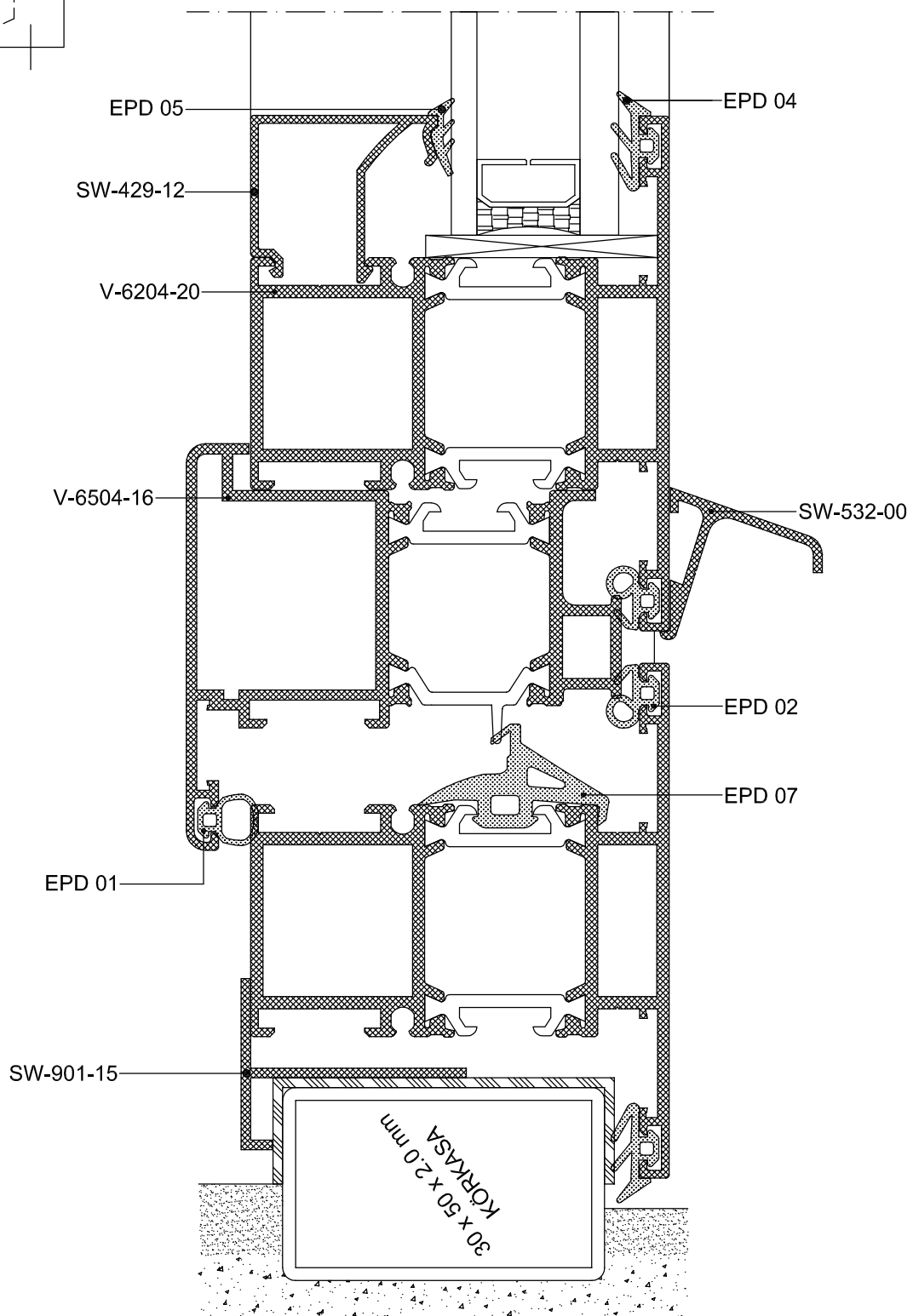

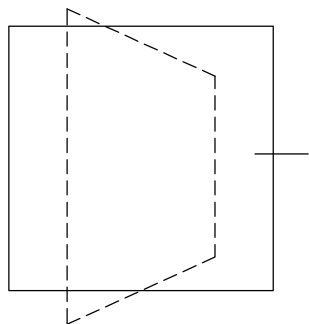

16

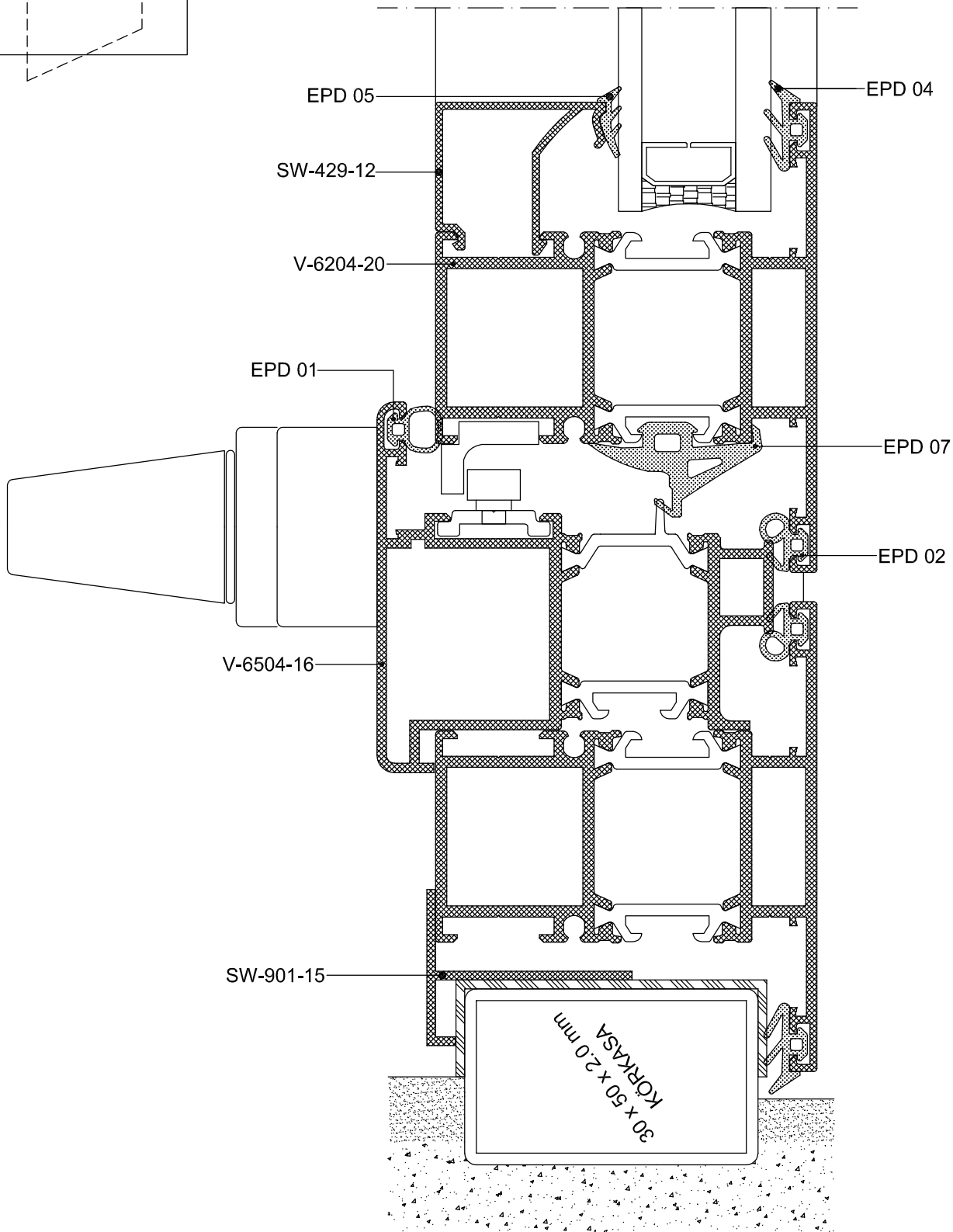

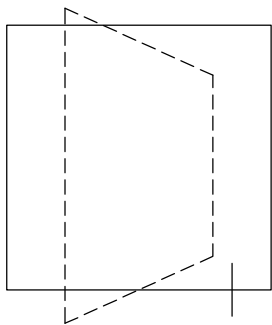

17

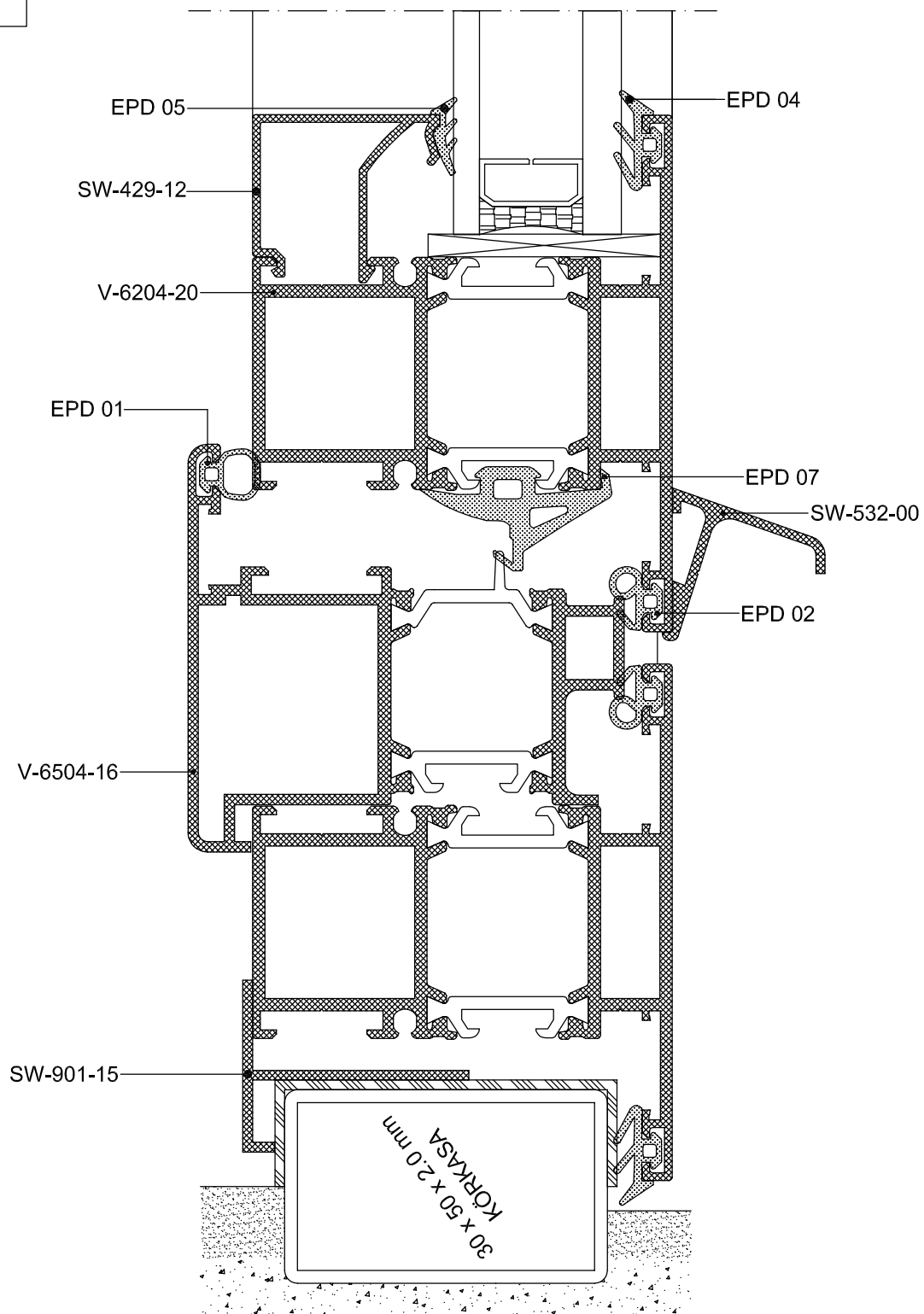

18

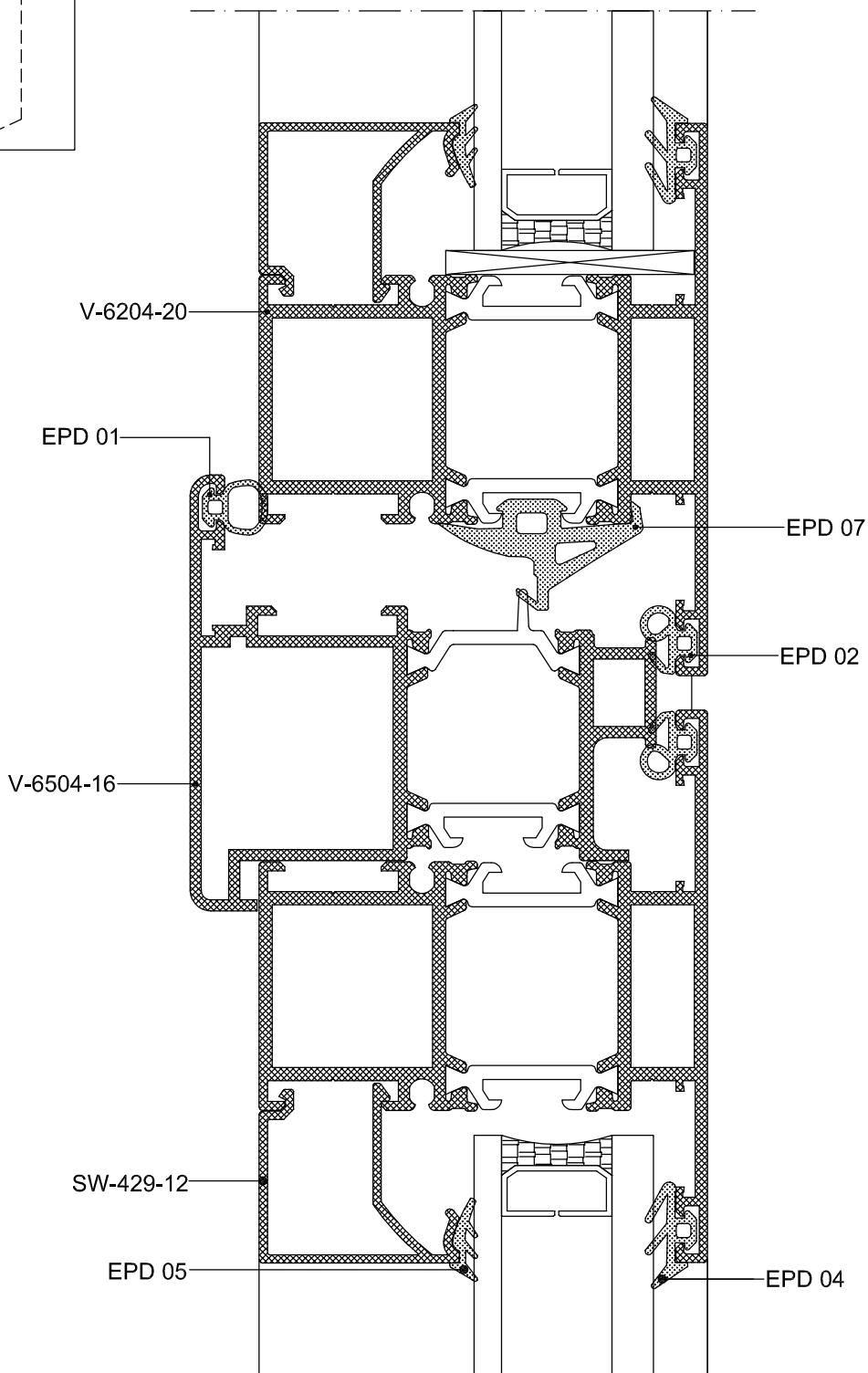
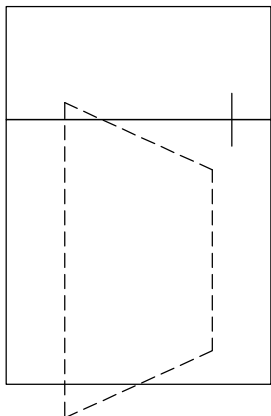

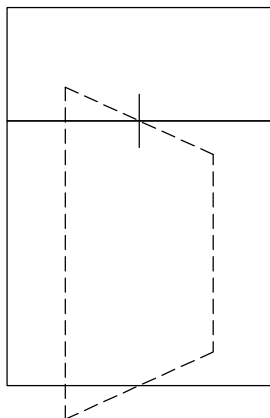

19

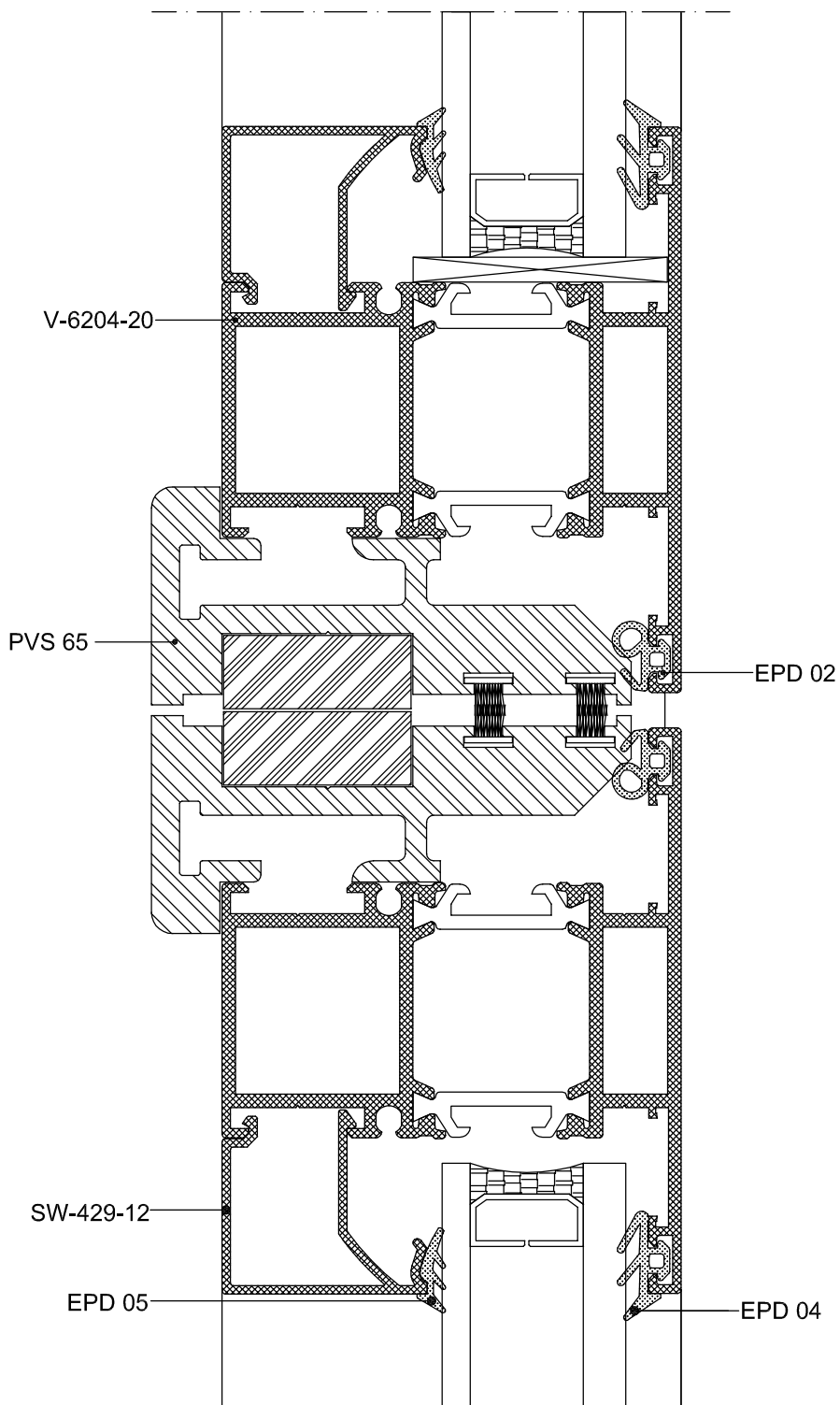

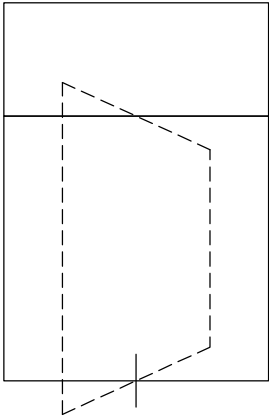

20

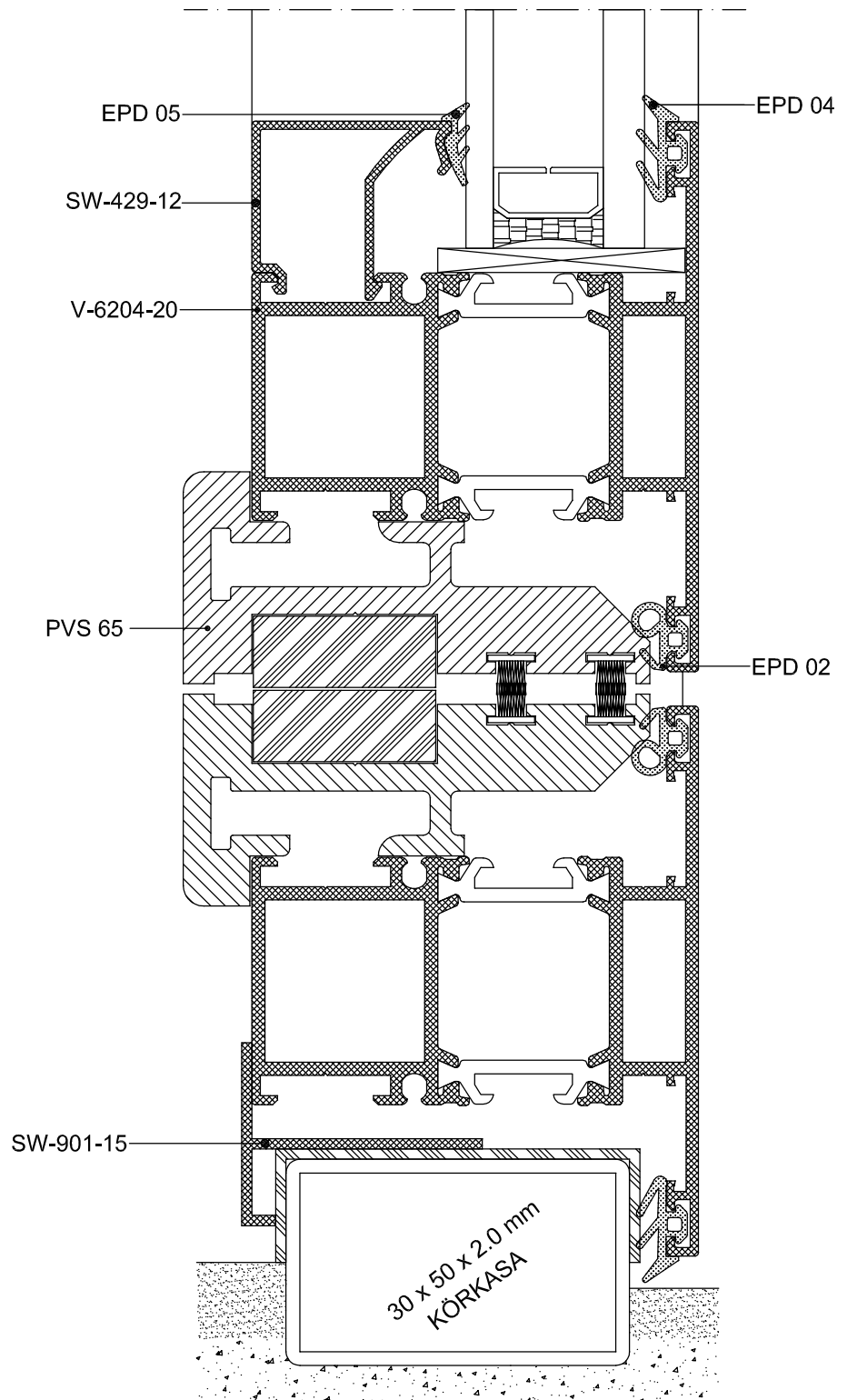

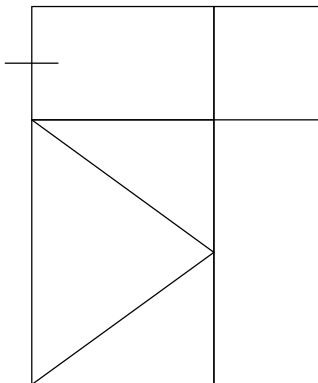

21

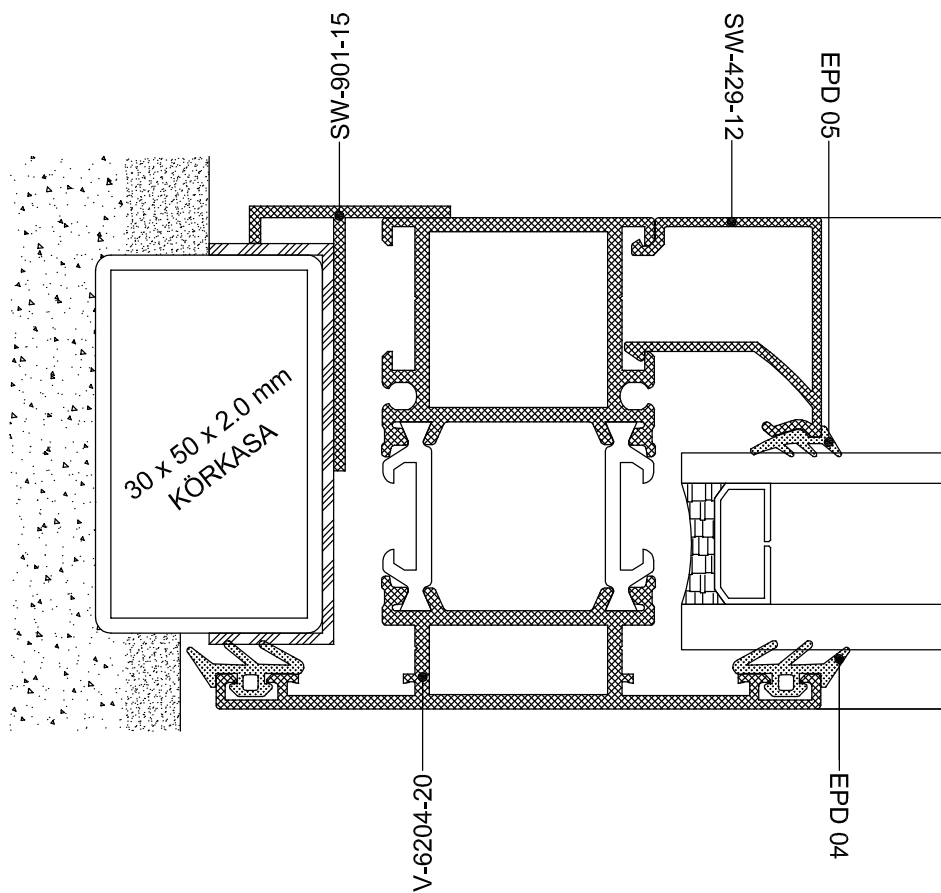

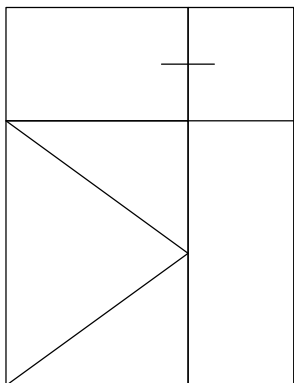

22

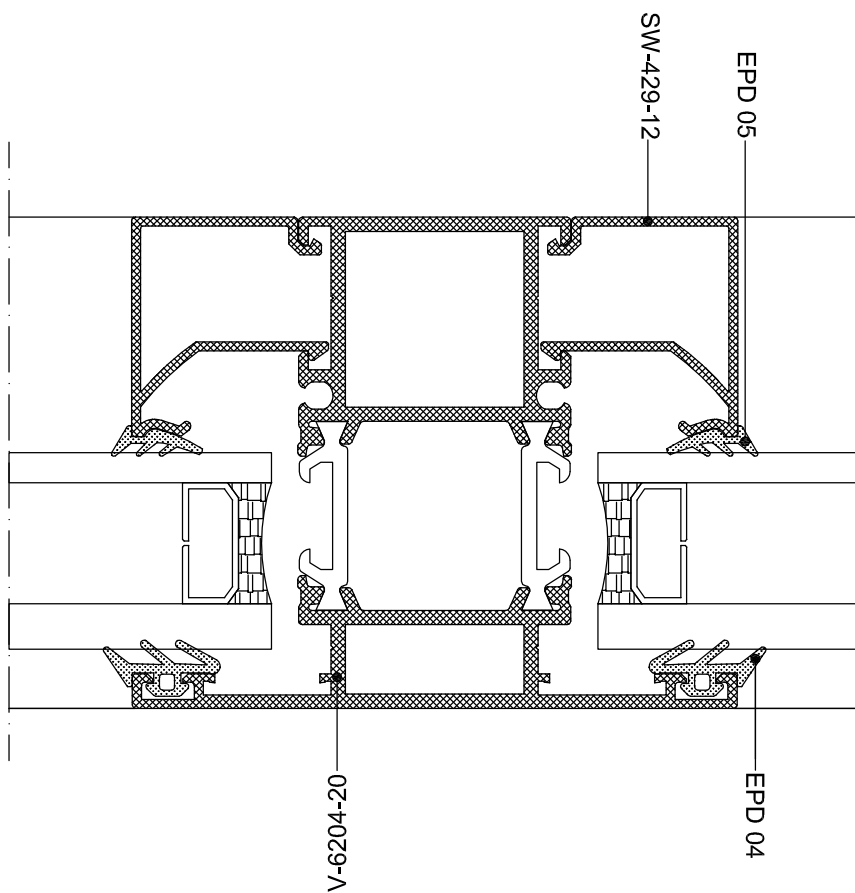

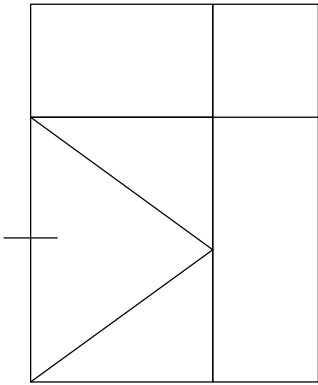

23

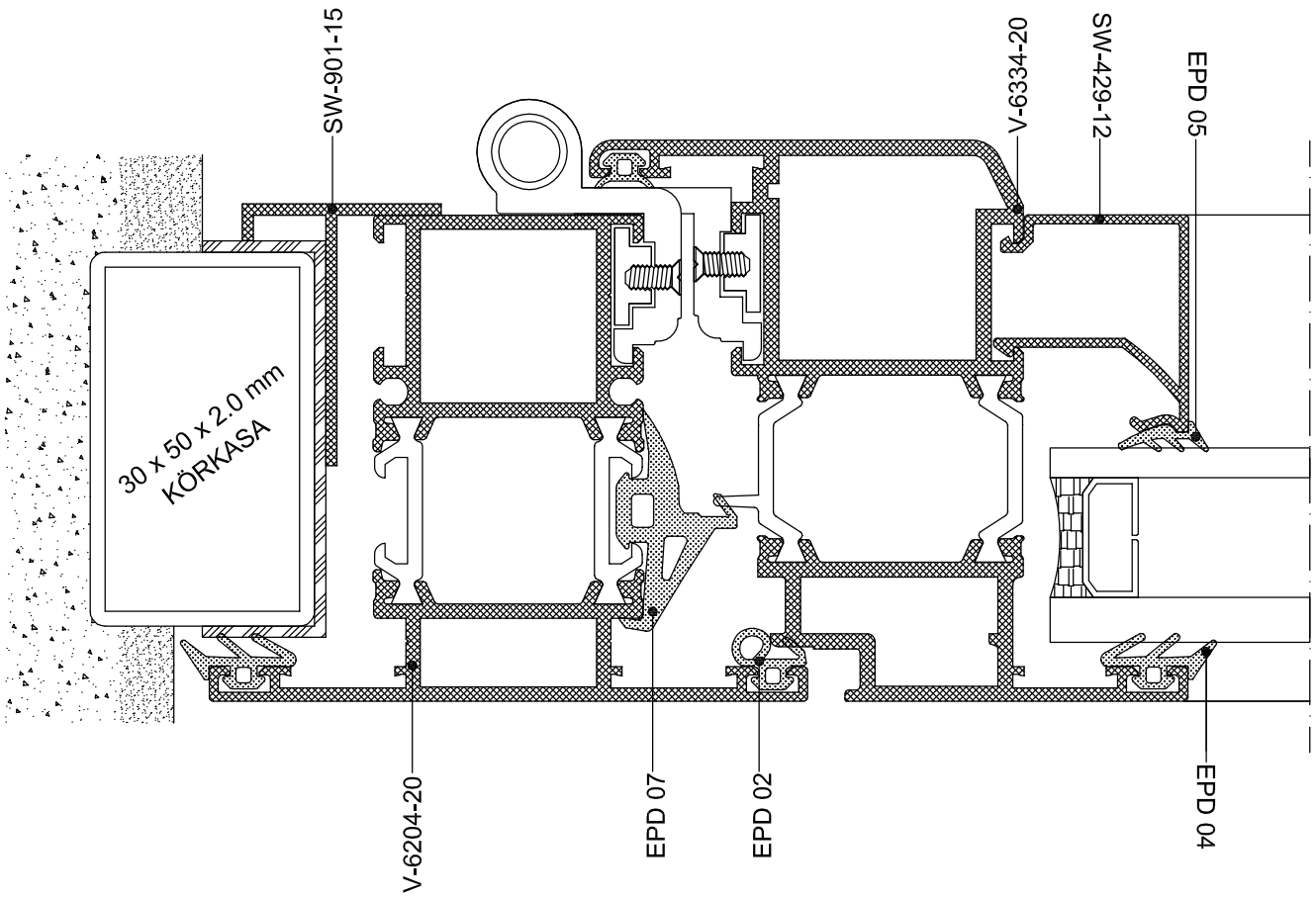

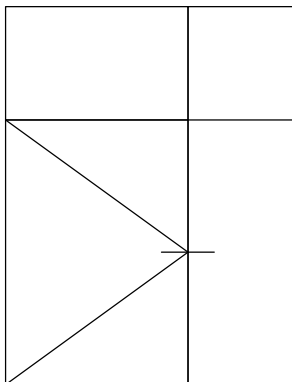

24

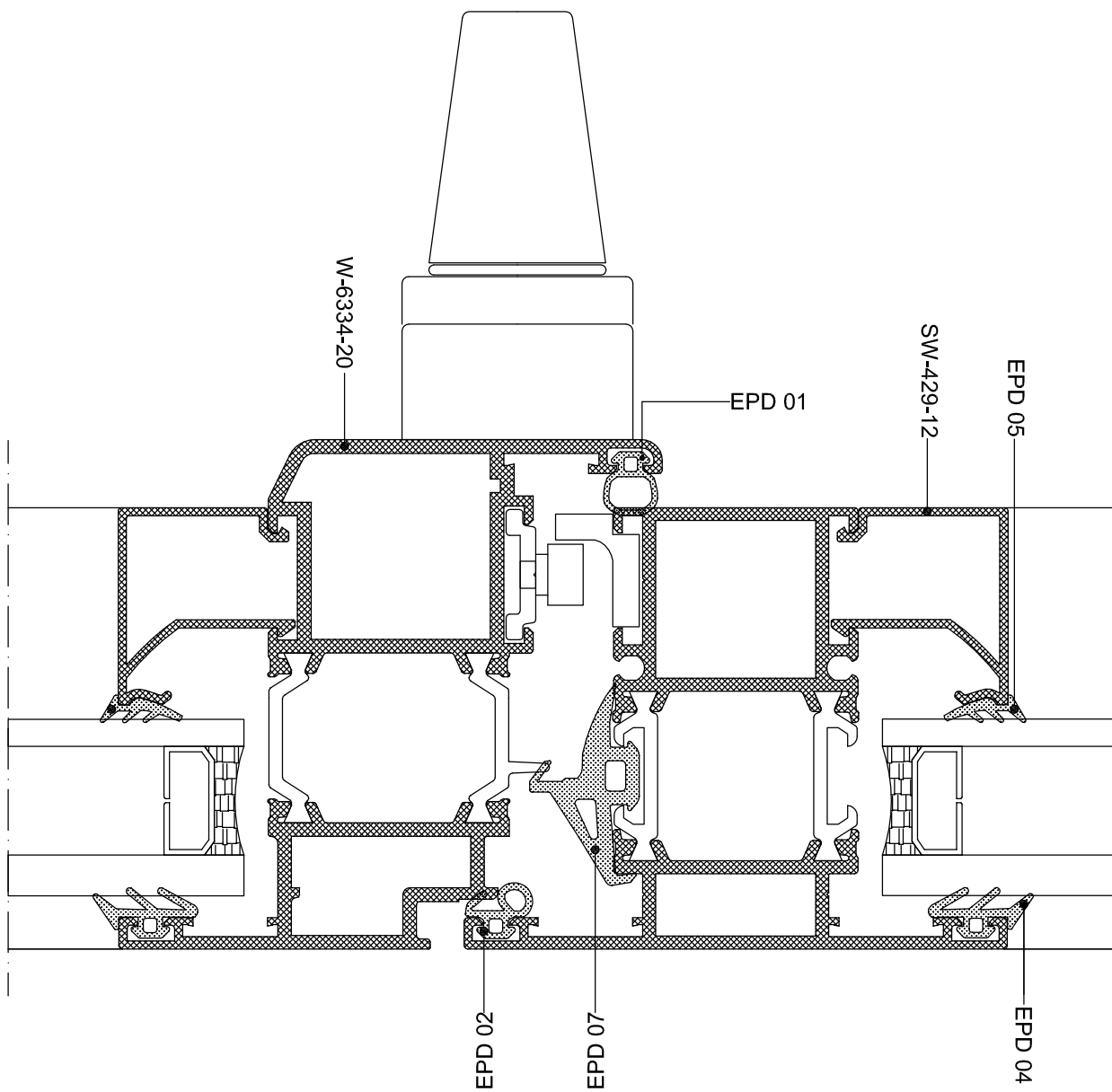

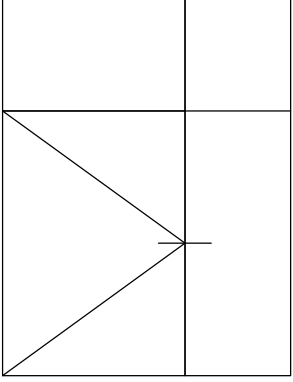

İSPANYOLET İLE KANAT
TEŞKİLİ

24*

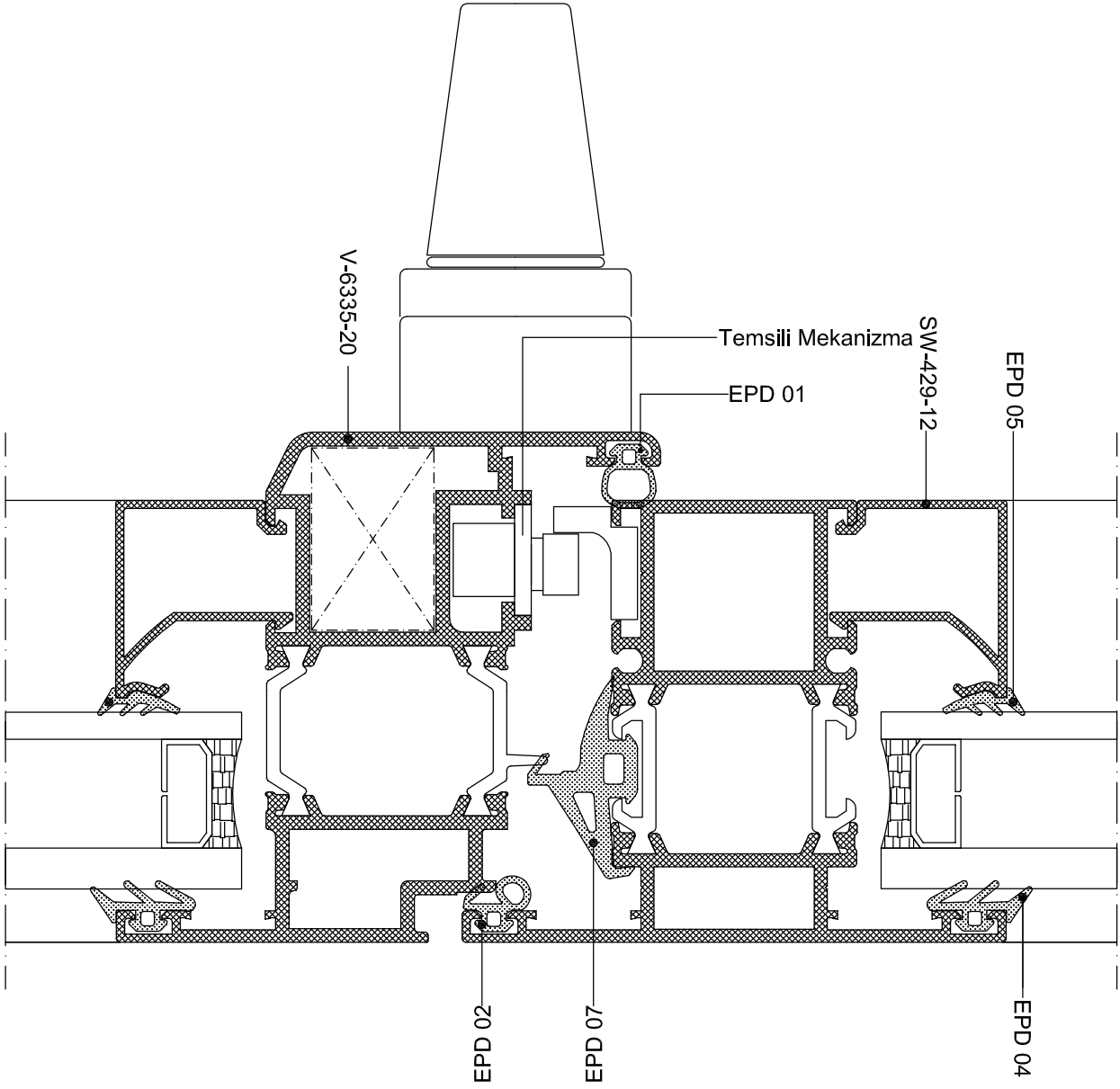

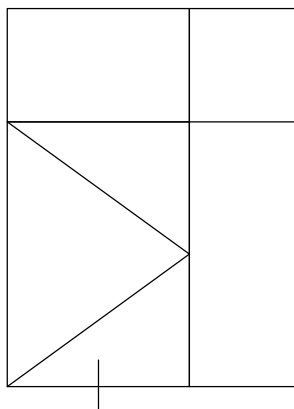

25

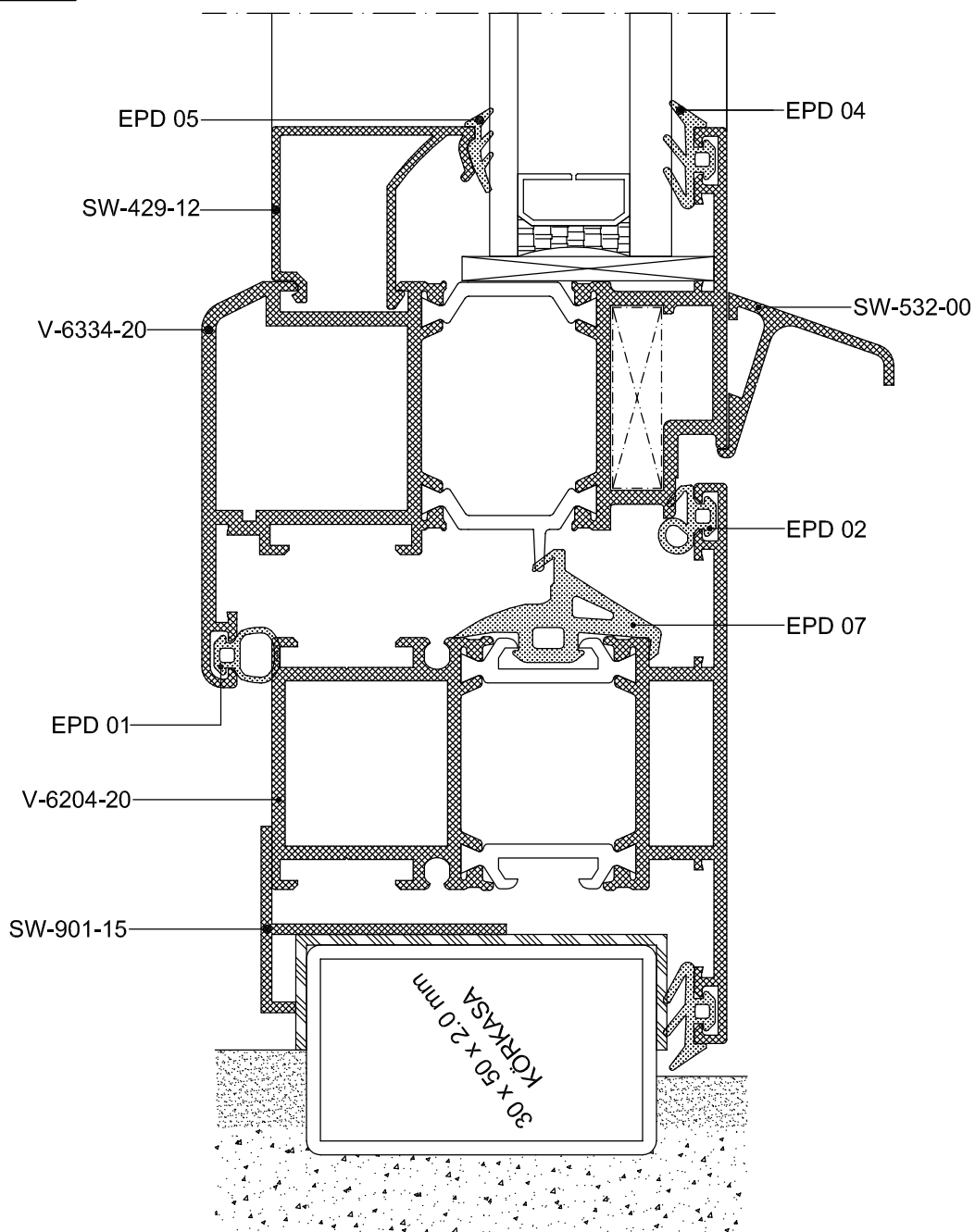

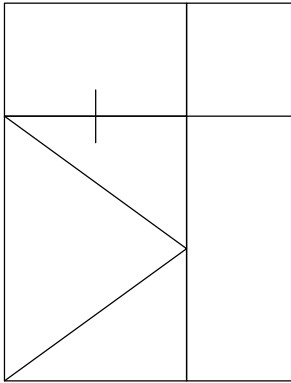

26

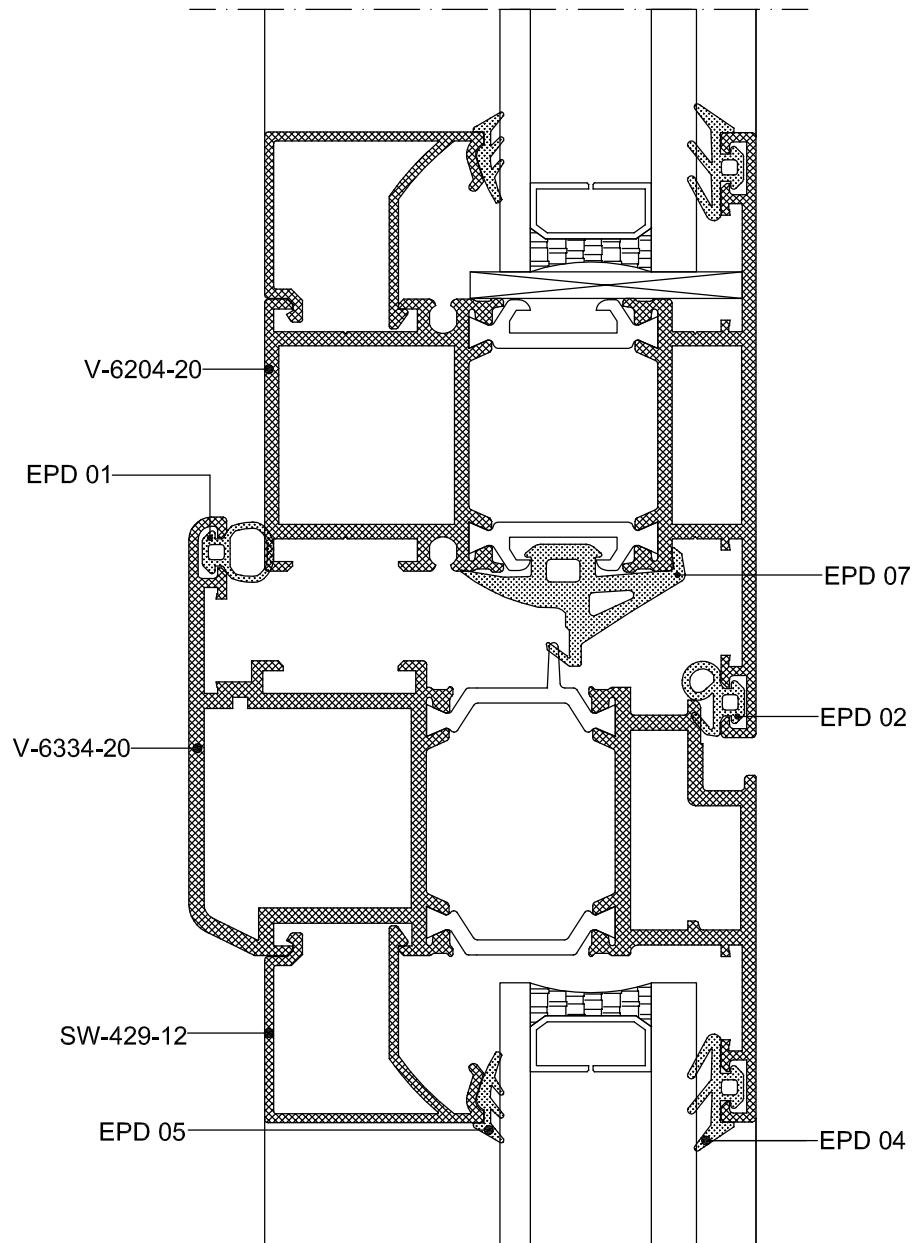

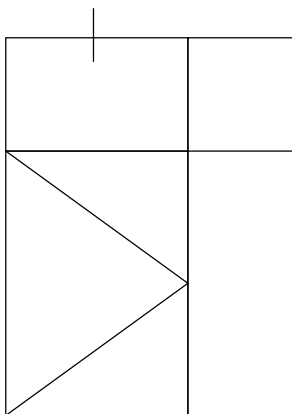

27

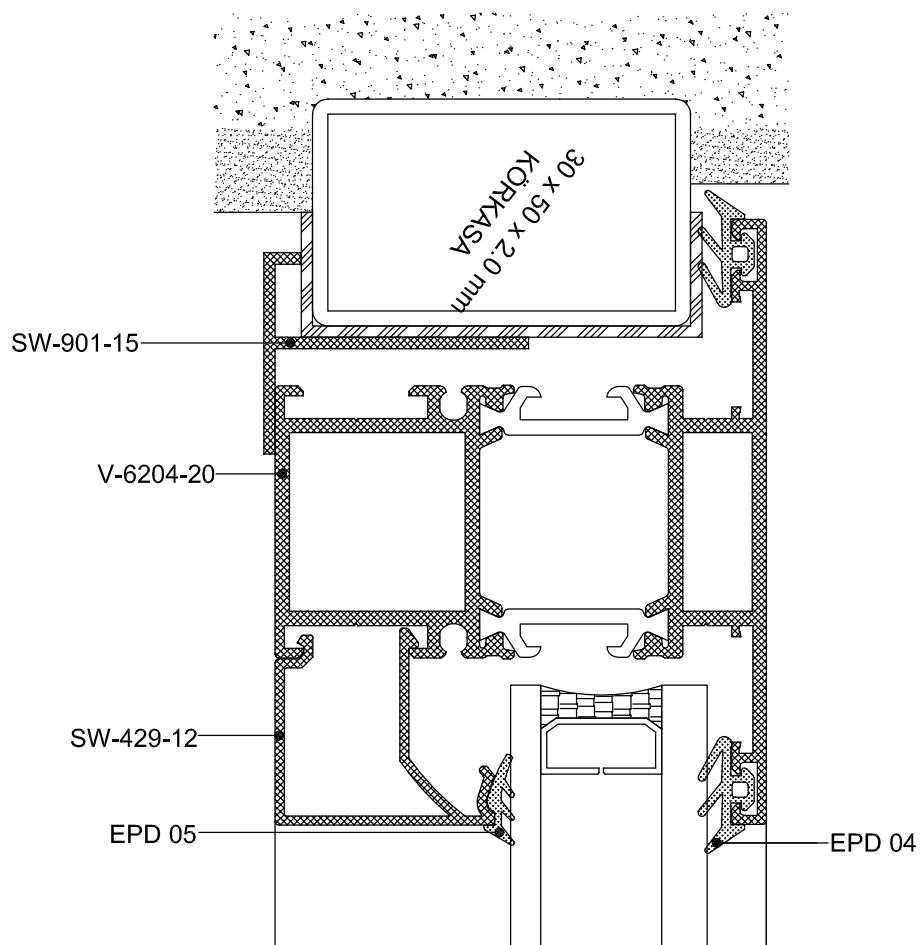

28

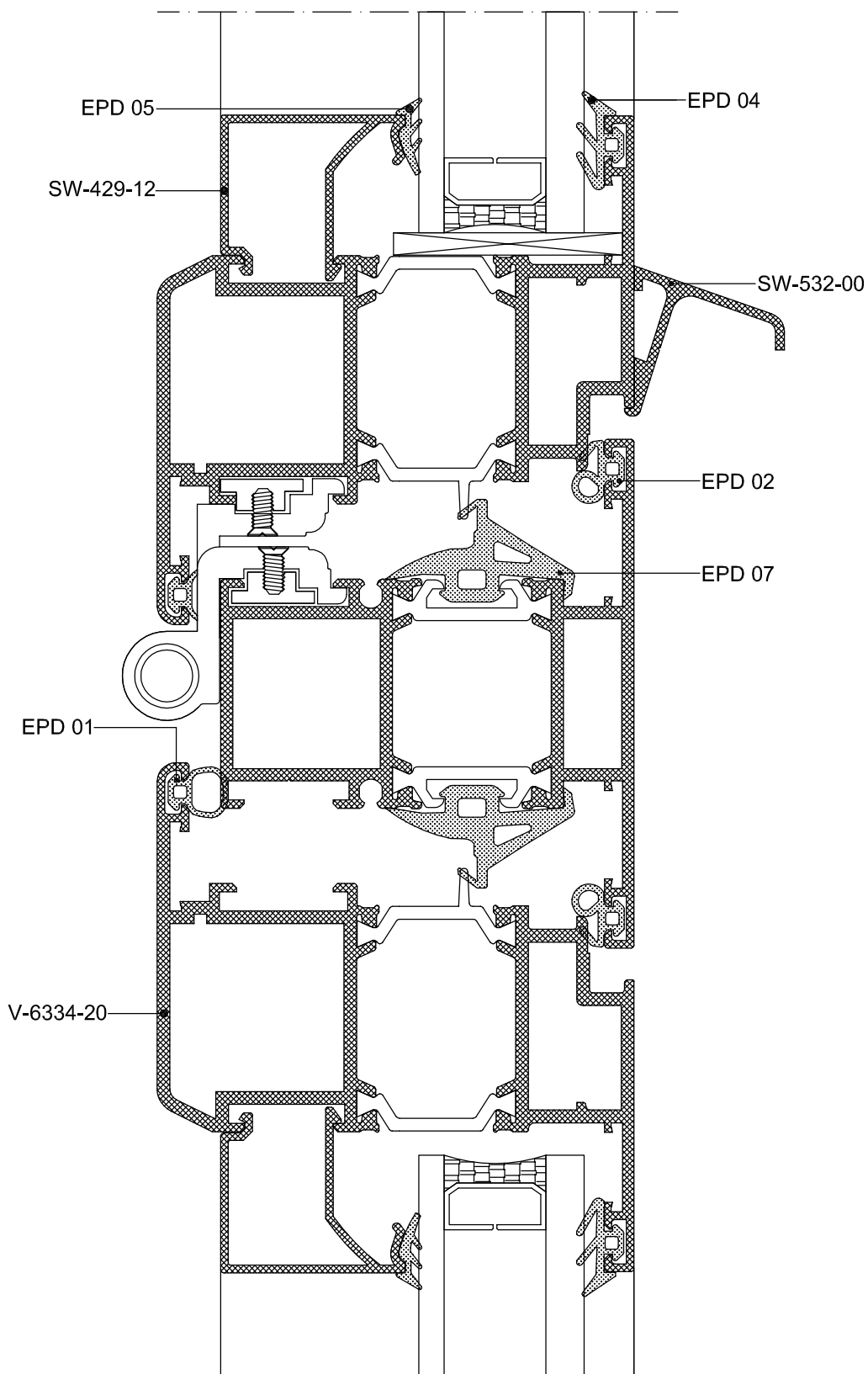
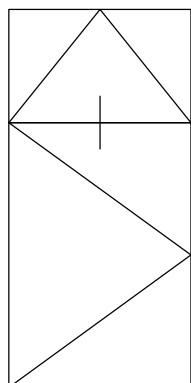

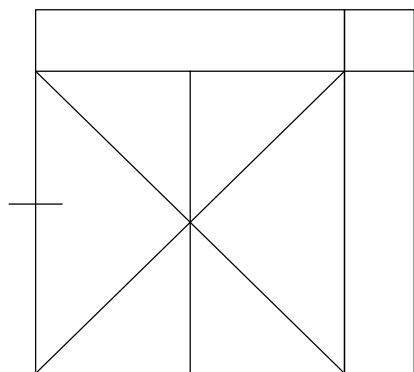

29

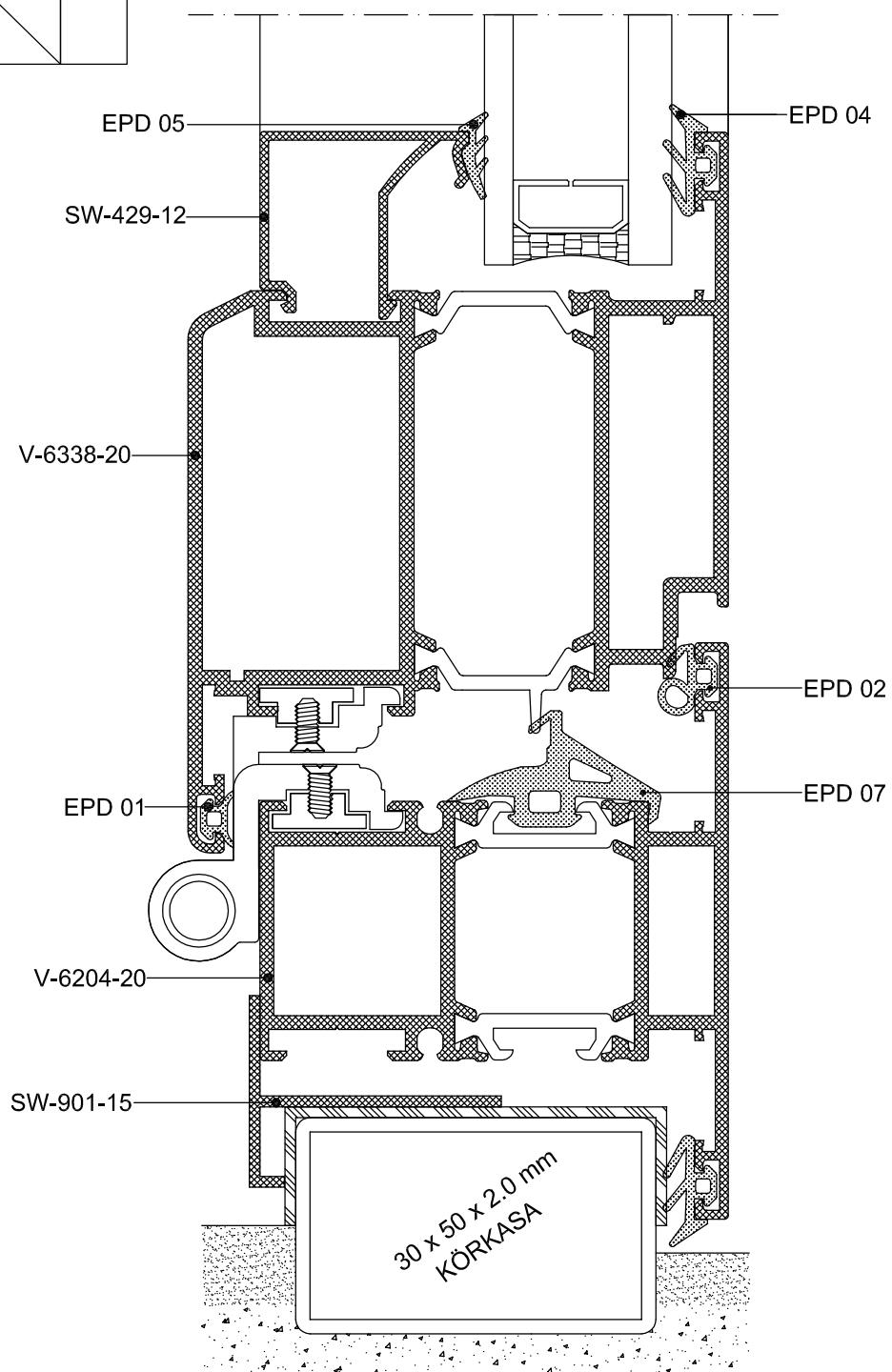

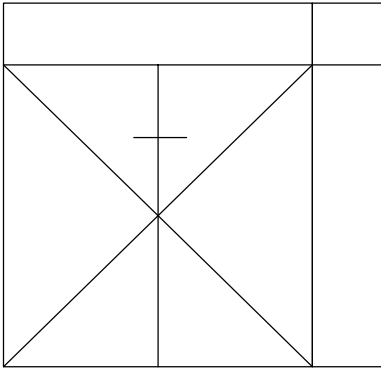

30

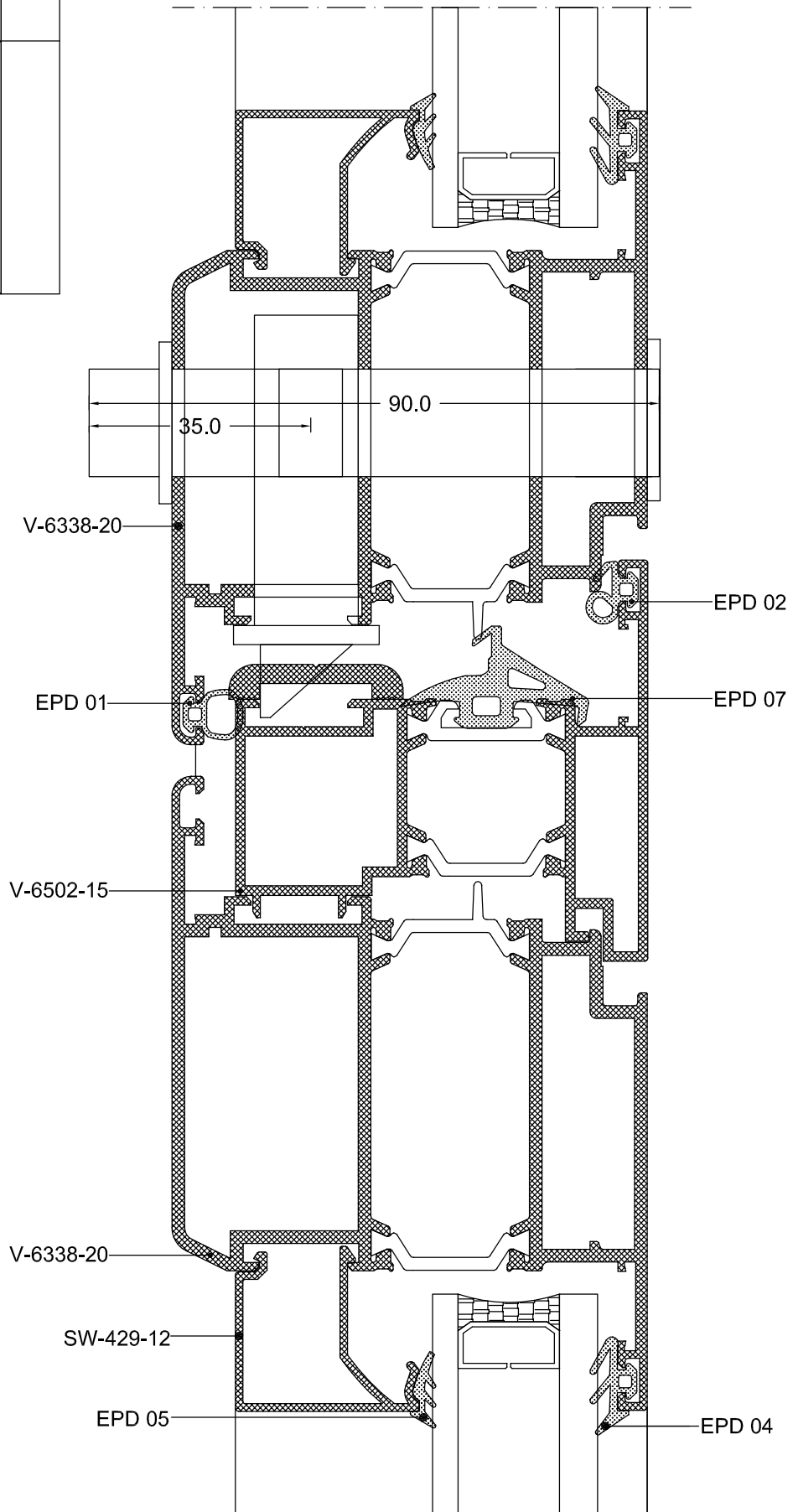

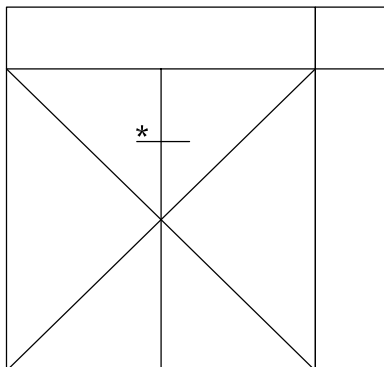

31

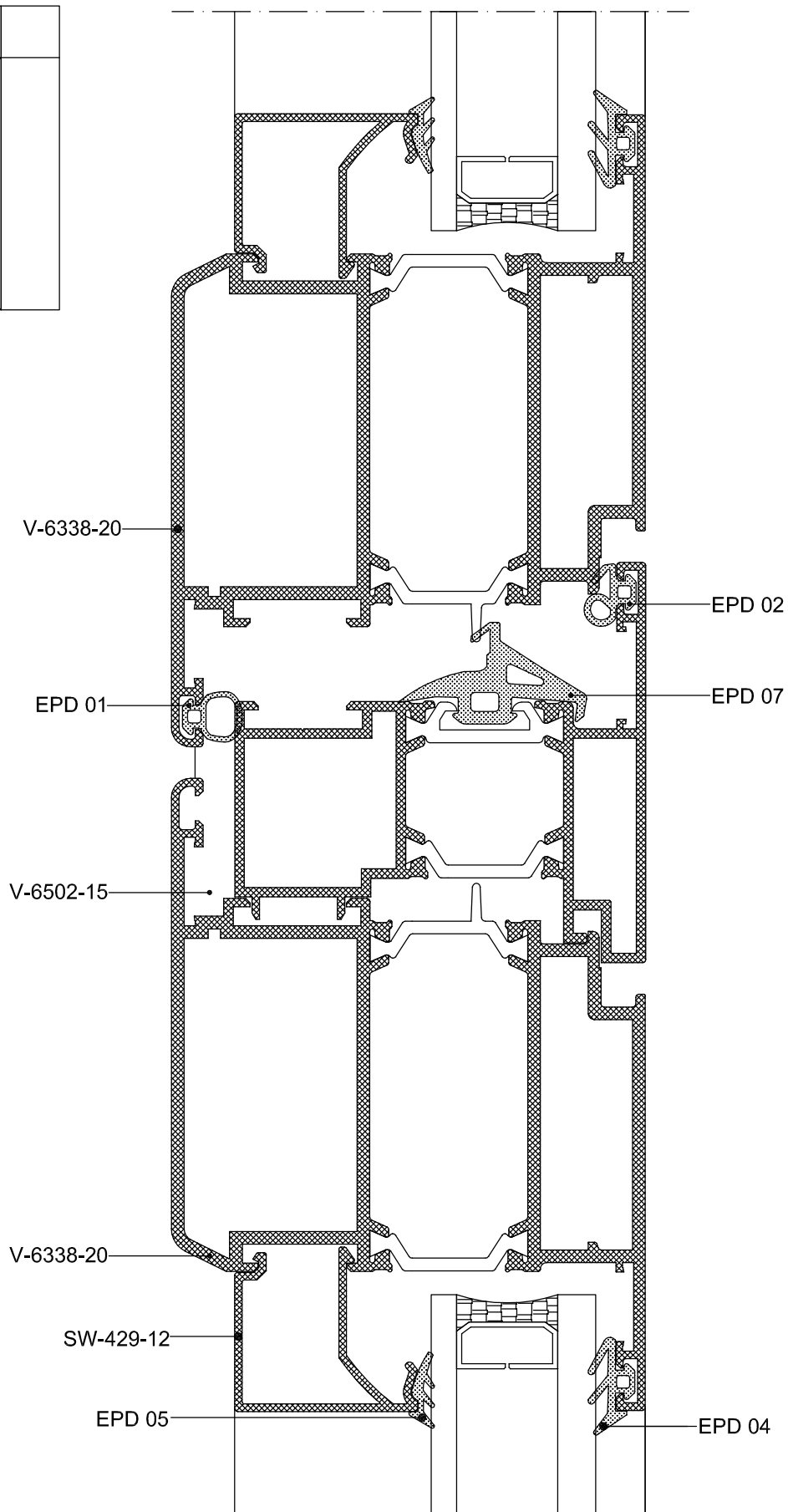

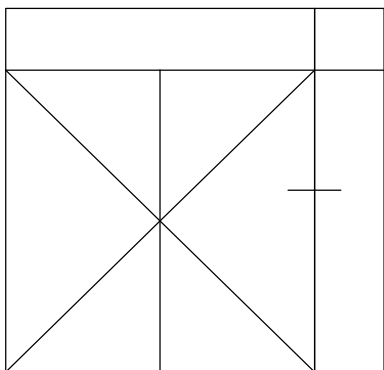

32

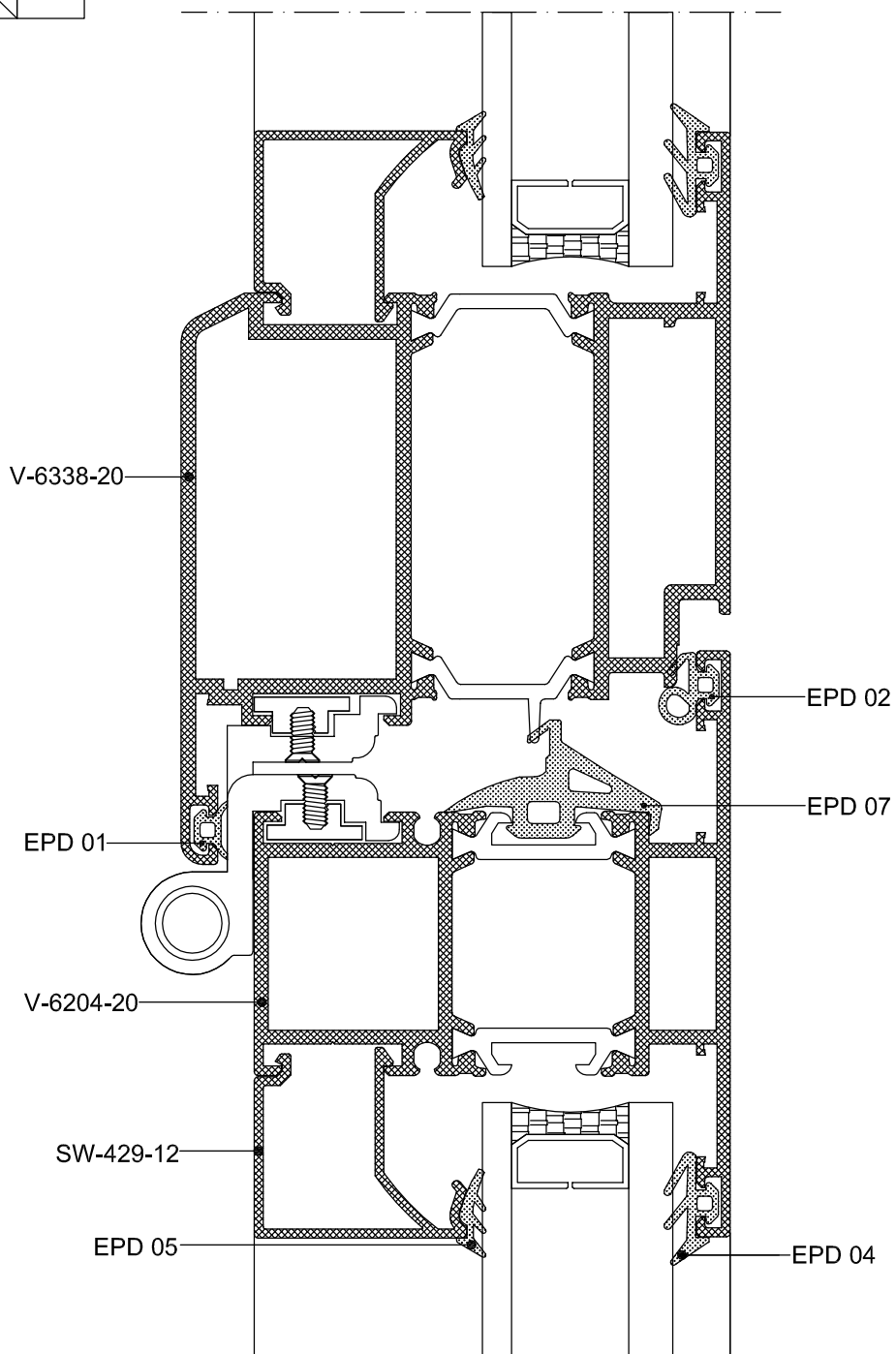

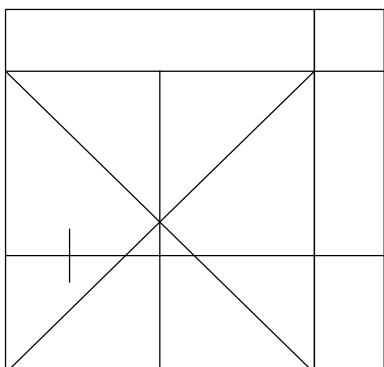

33

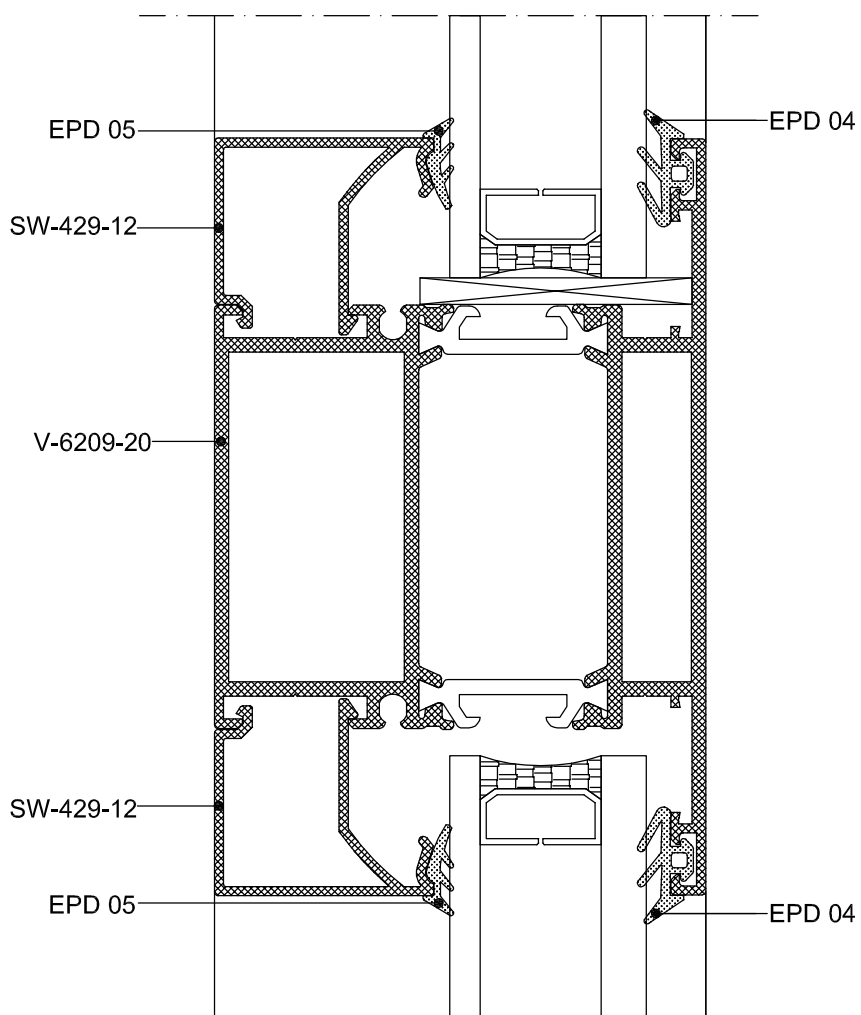

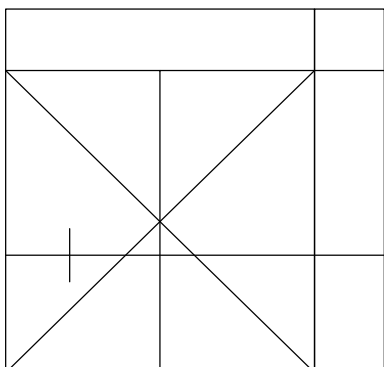

34

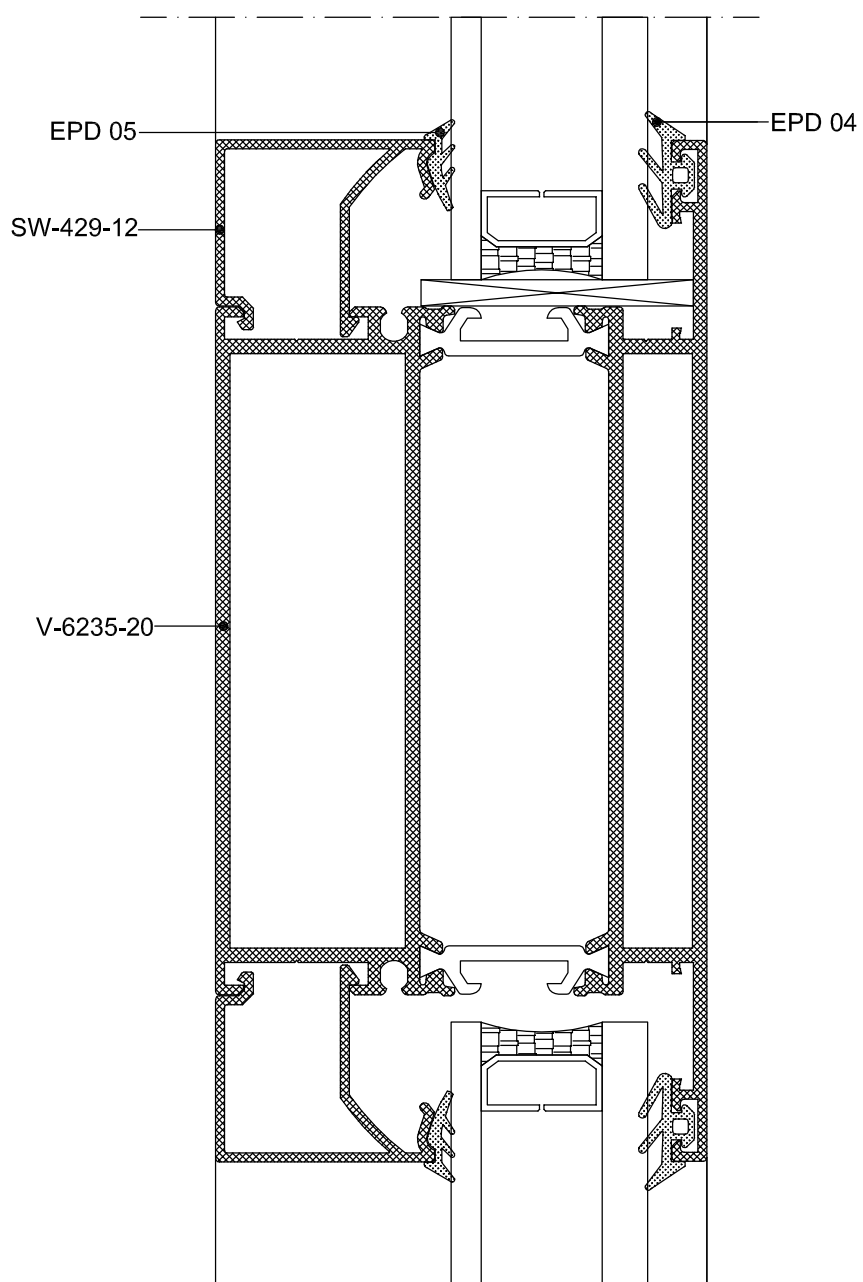

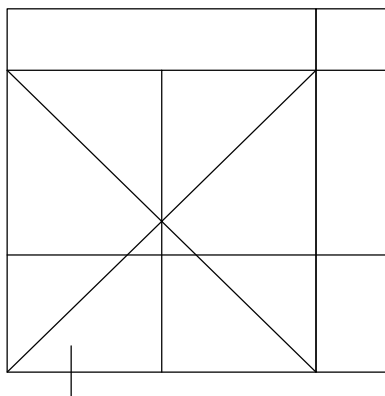

35

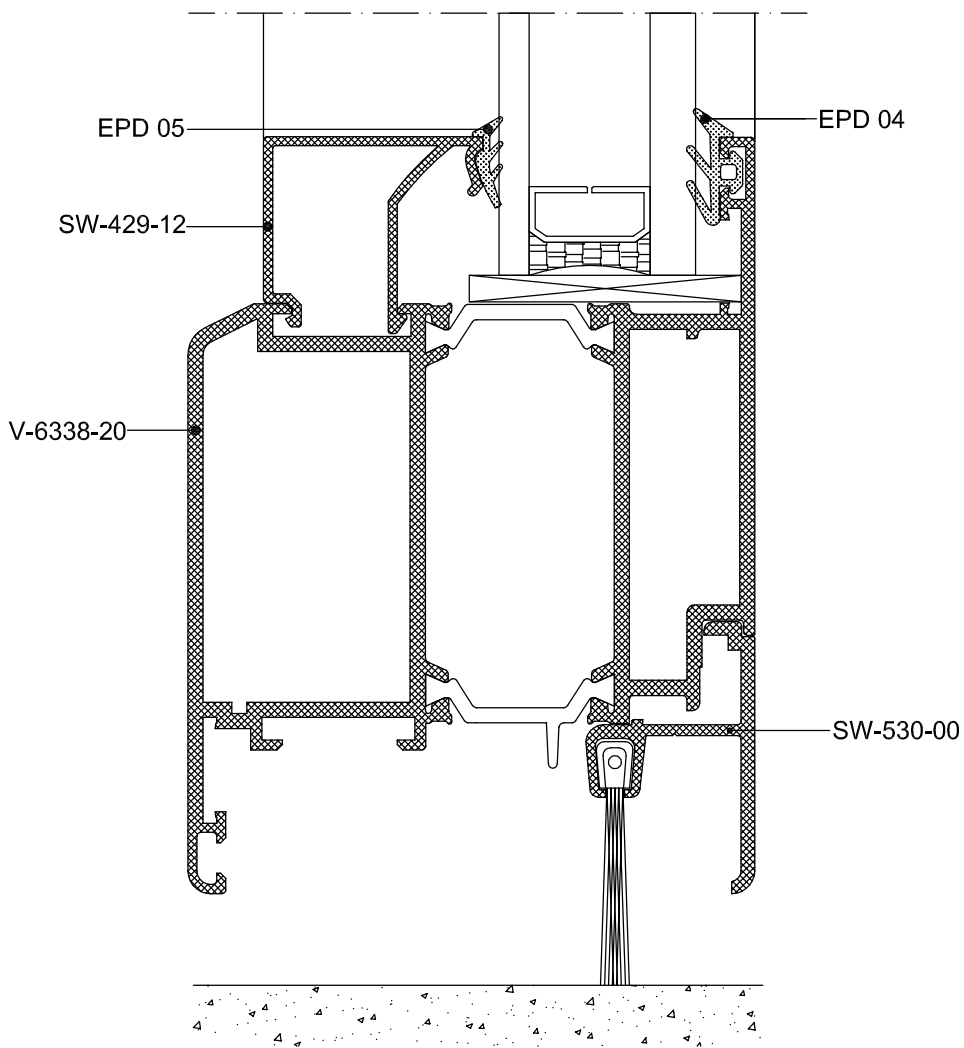

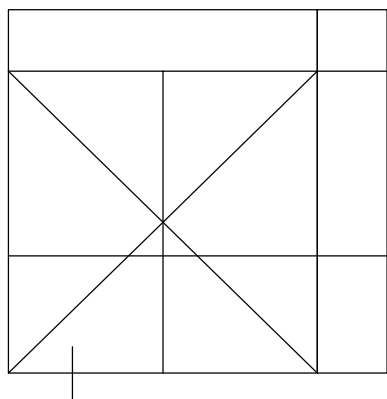

36

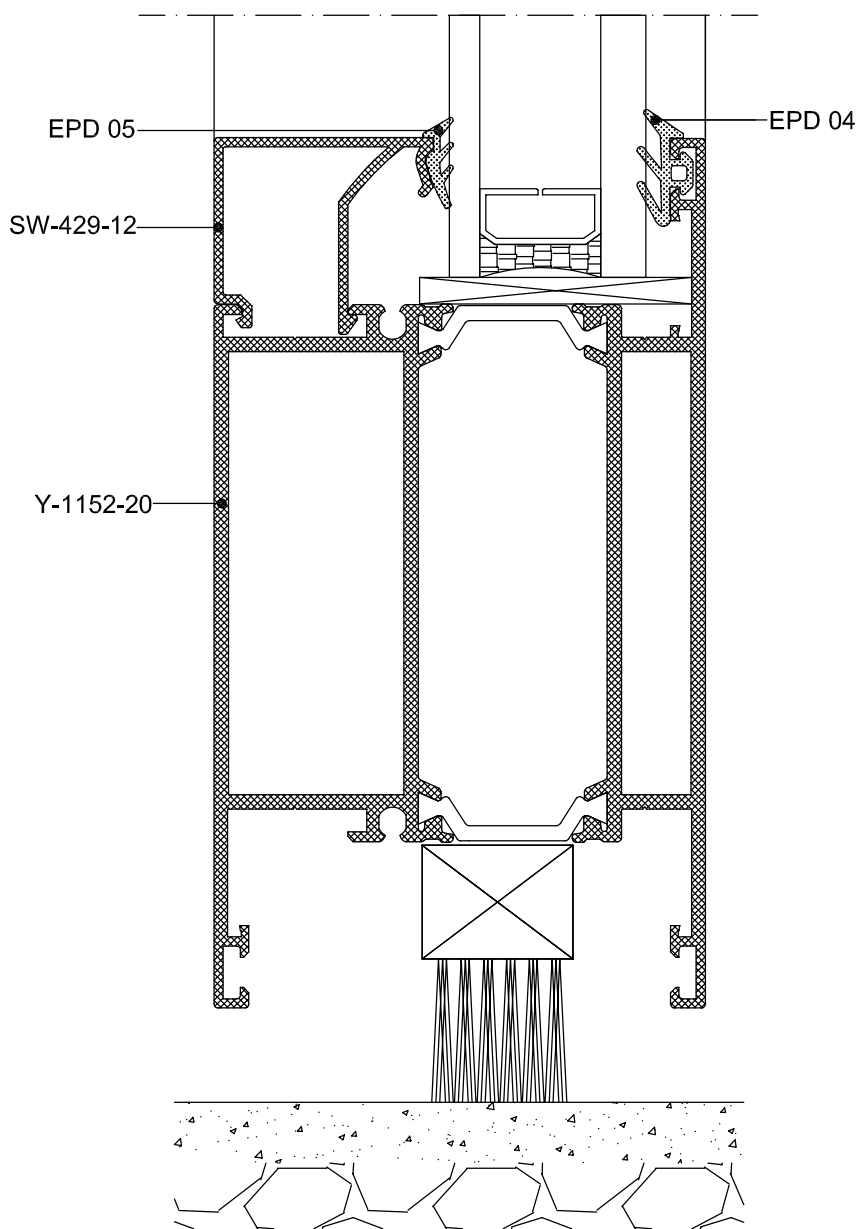

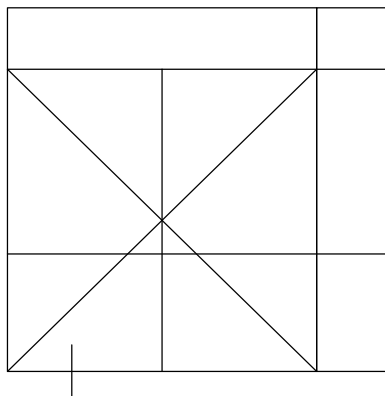

37

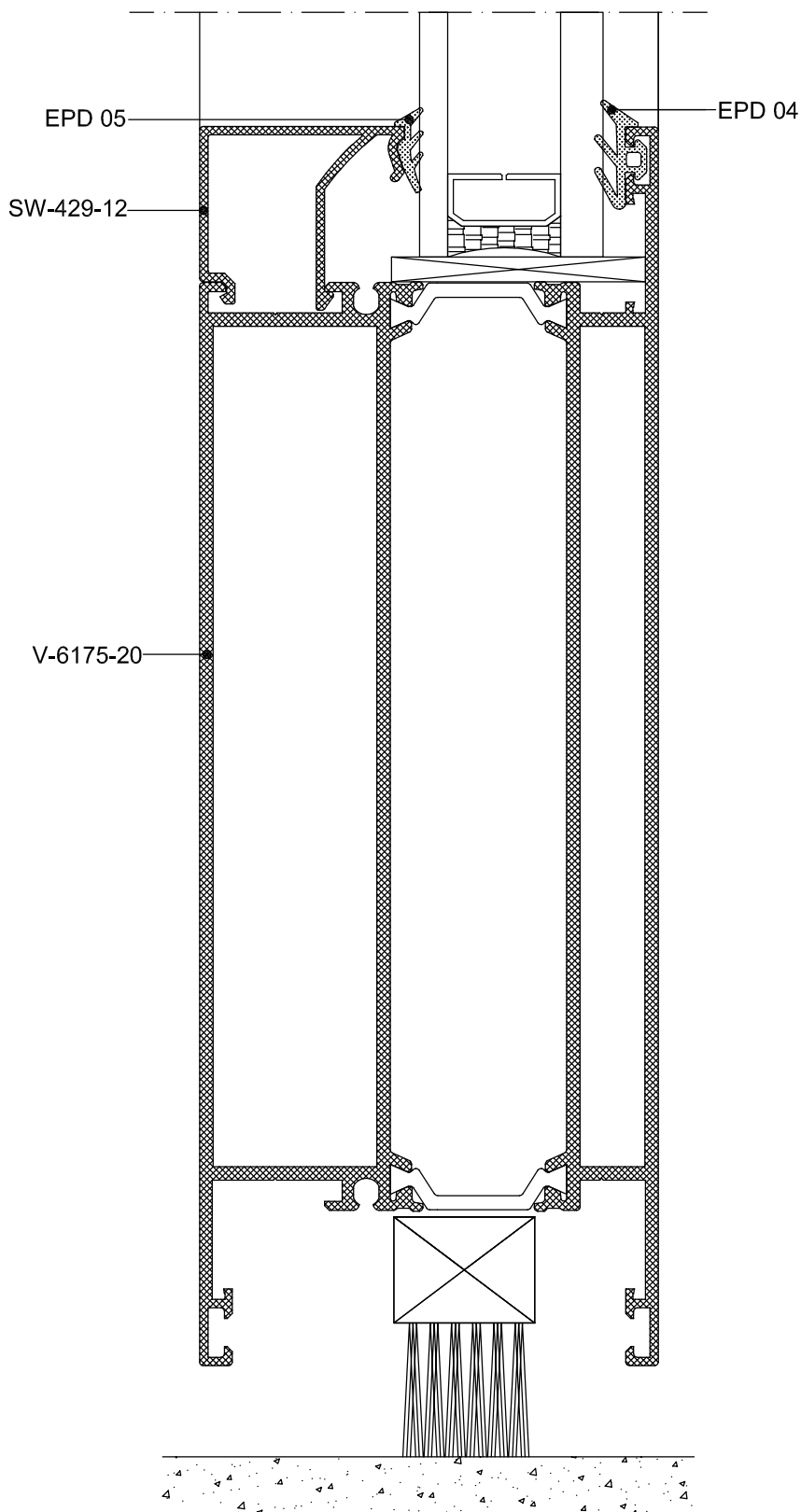

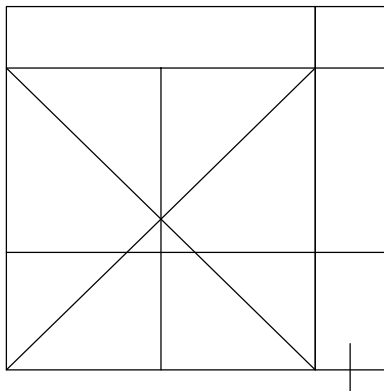

38

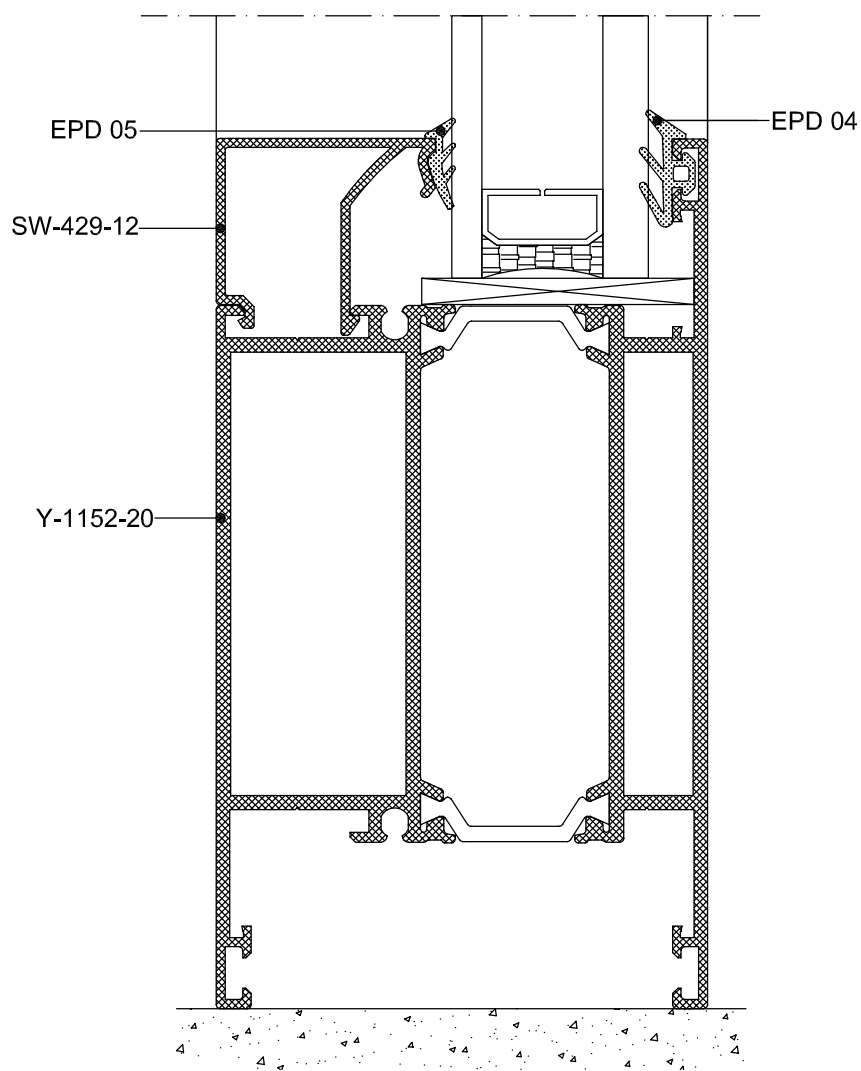

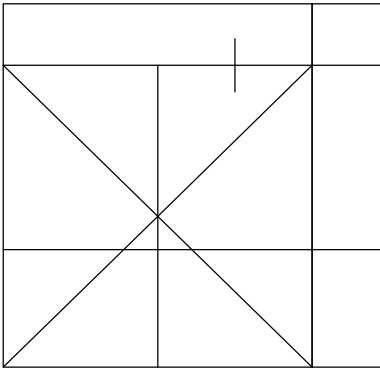

39

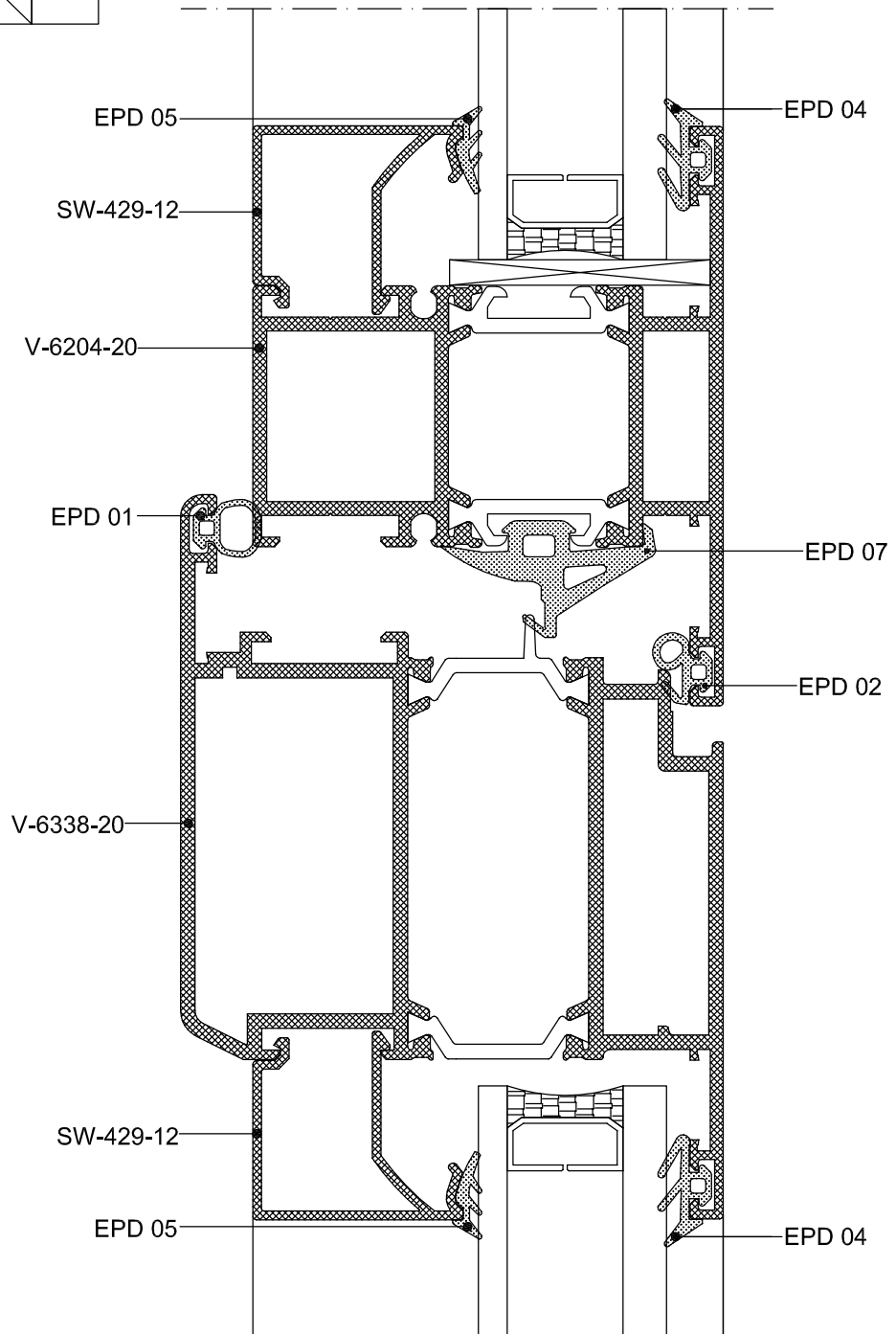

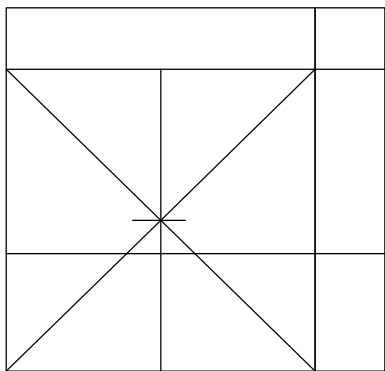

40

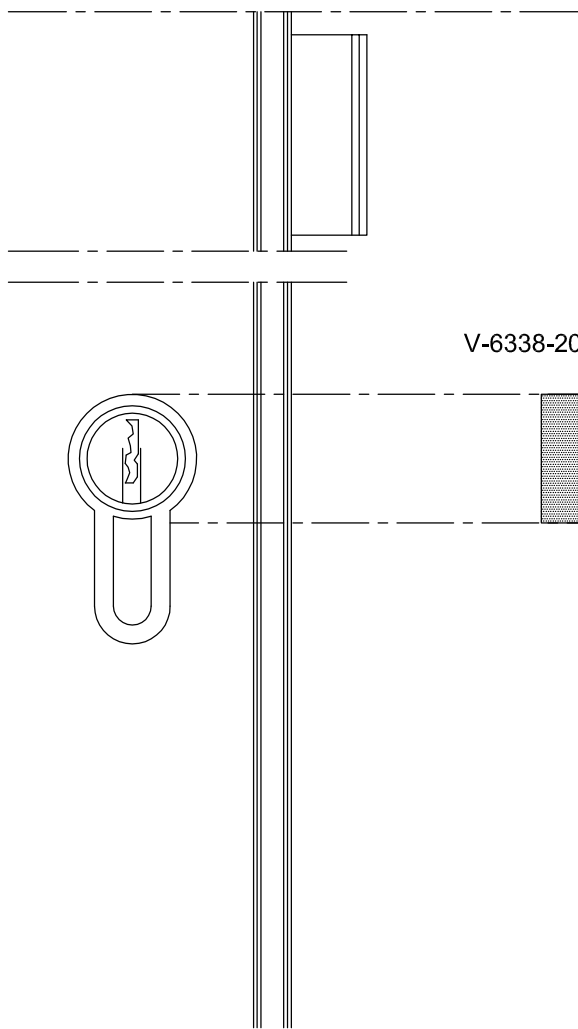

V-6338-20

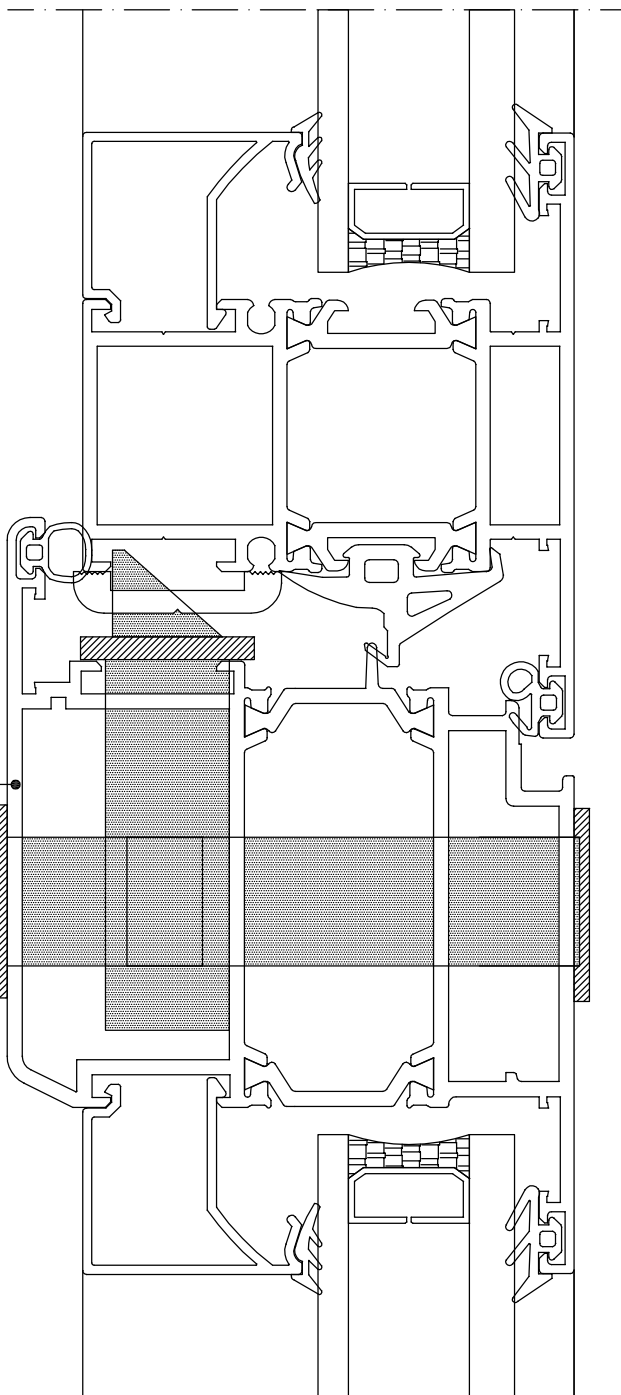

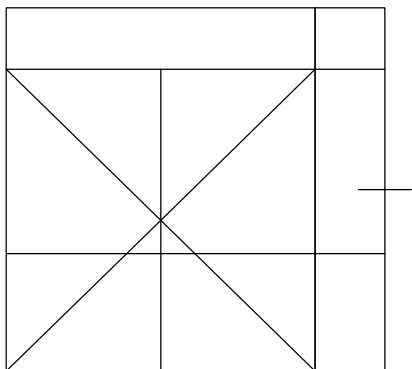

41

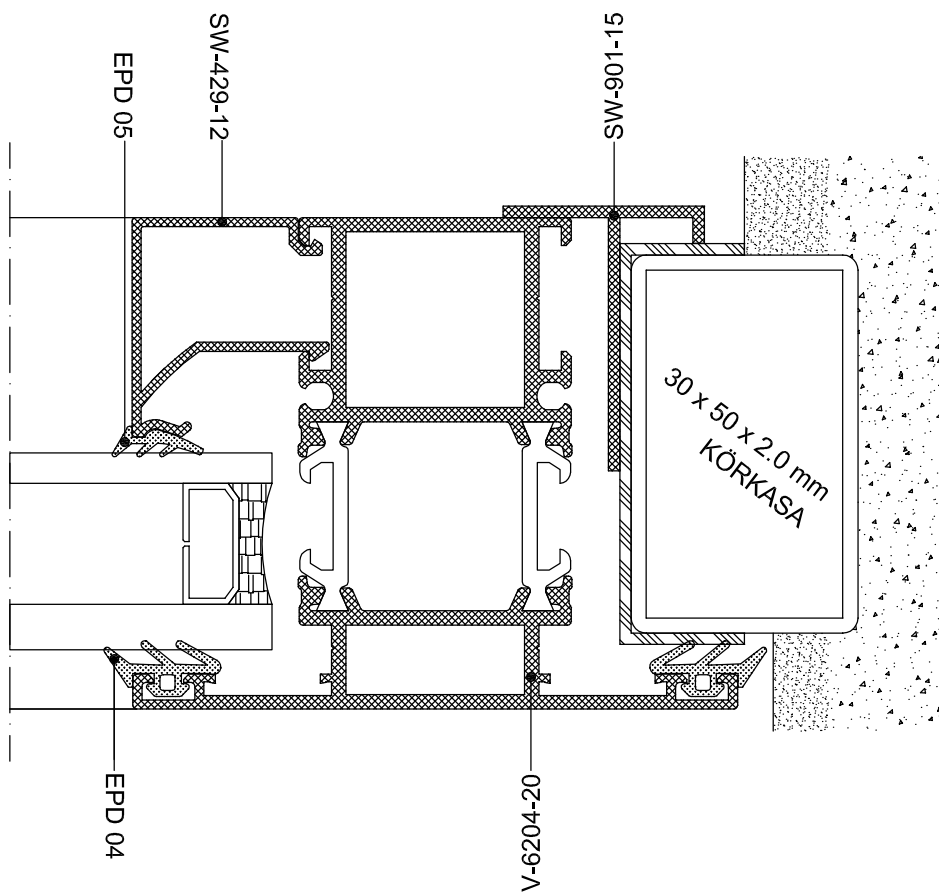

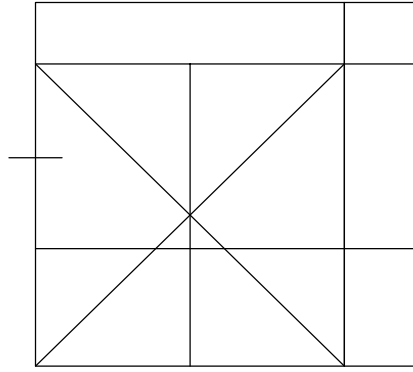

DIŐA AÇILIR KAPI

DIŐA AÇILIR KAPI UYGULAMA DETAYLARI

42

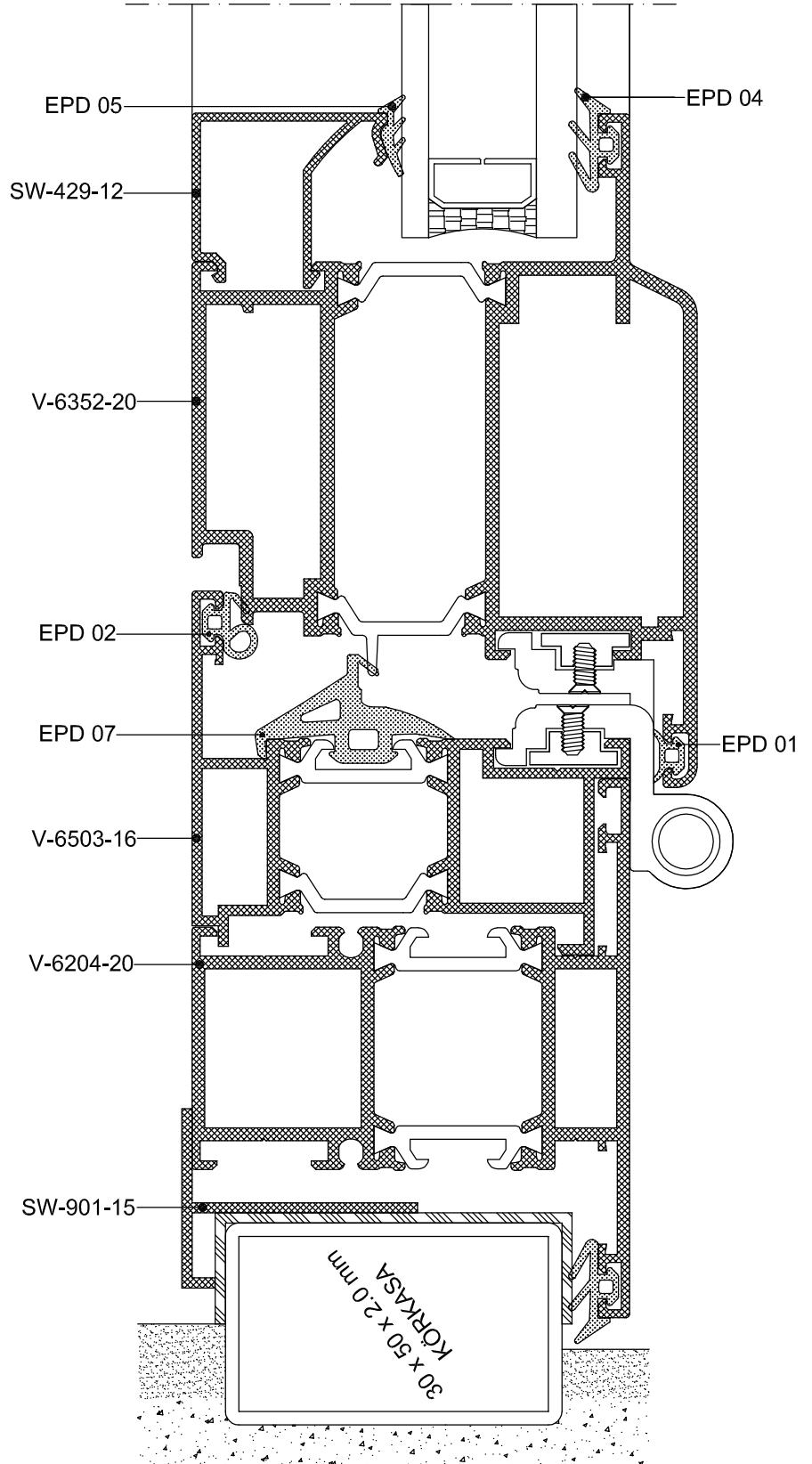

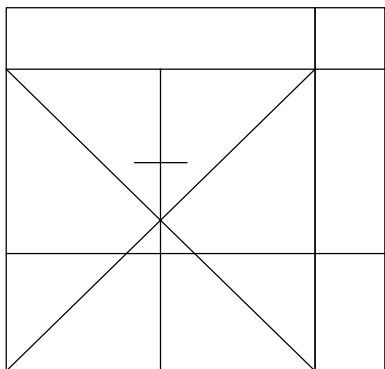

43

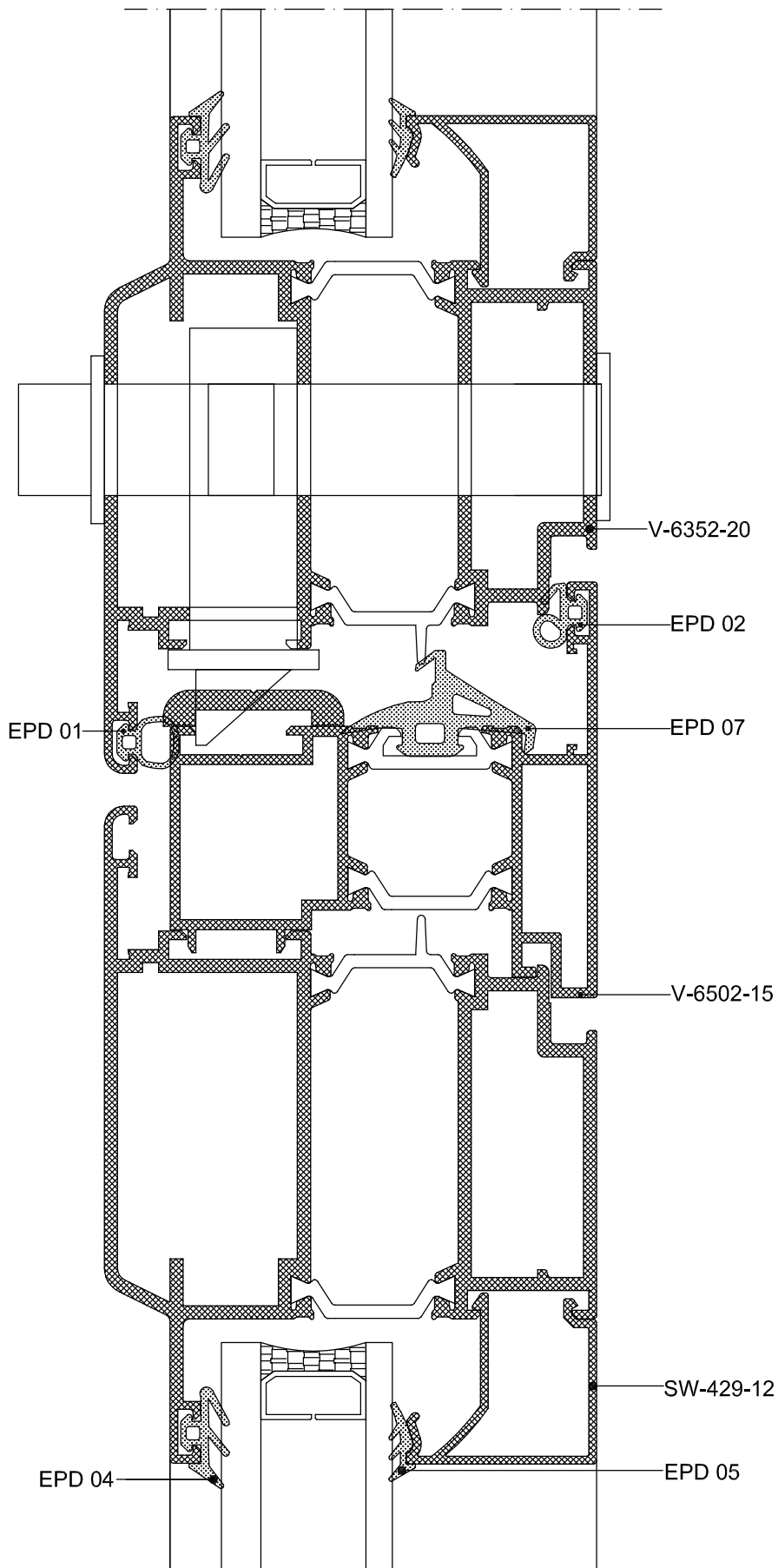

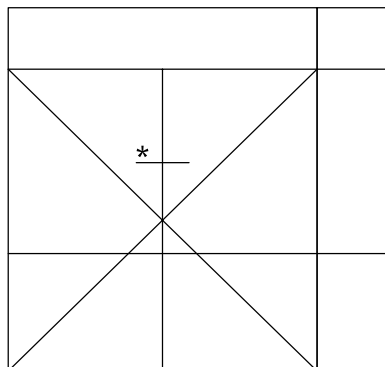

44

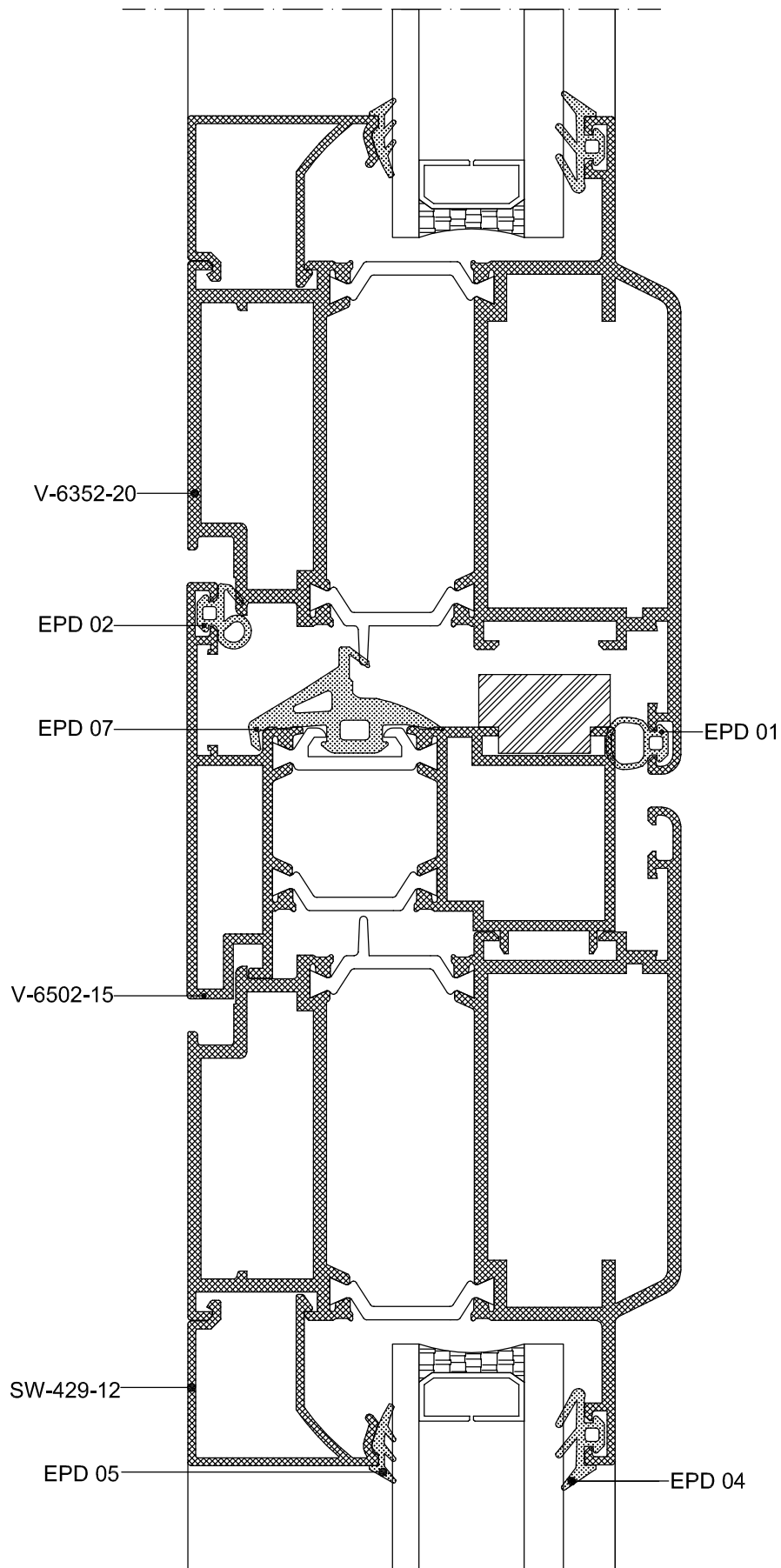

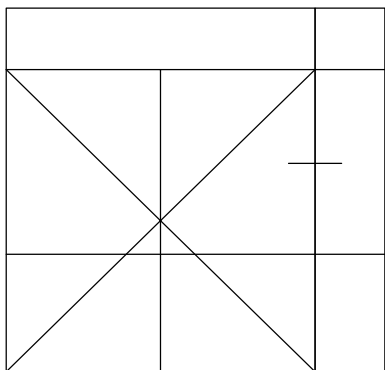

45

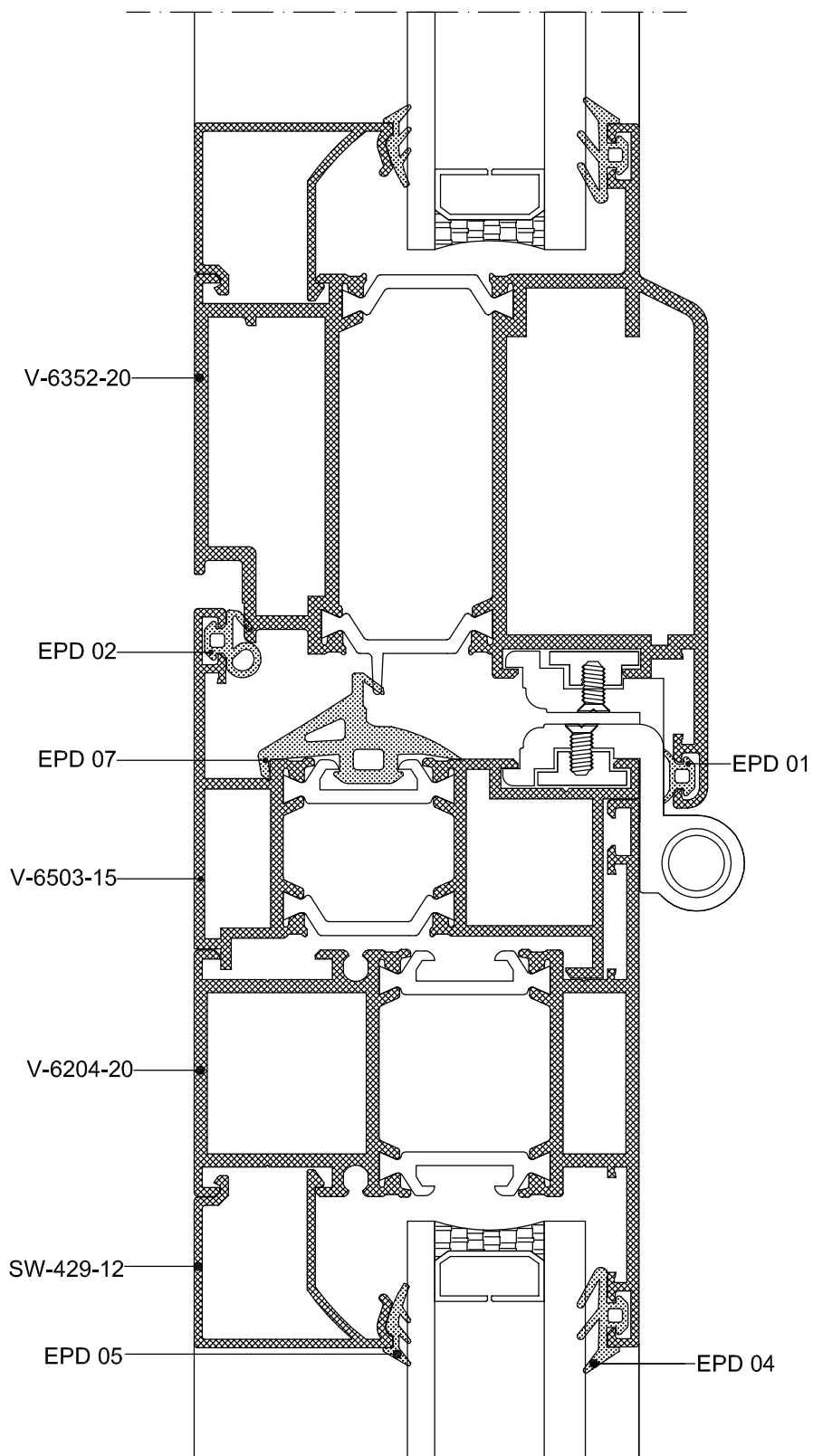

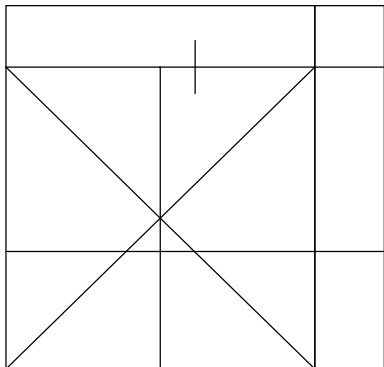

46

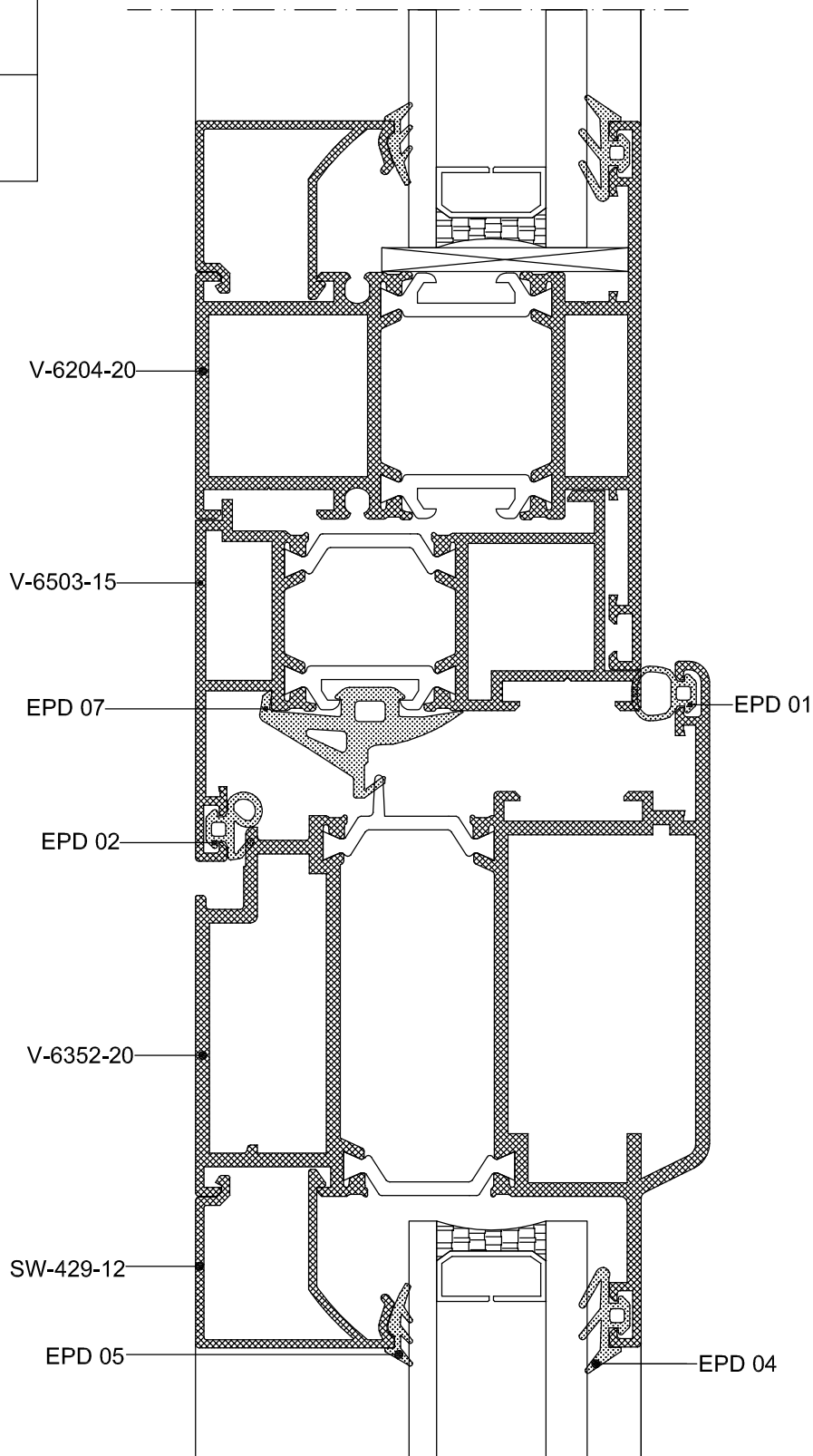

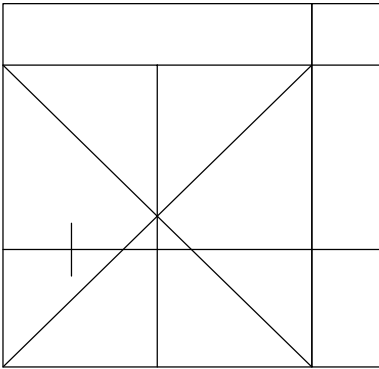

47

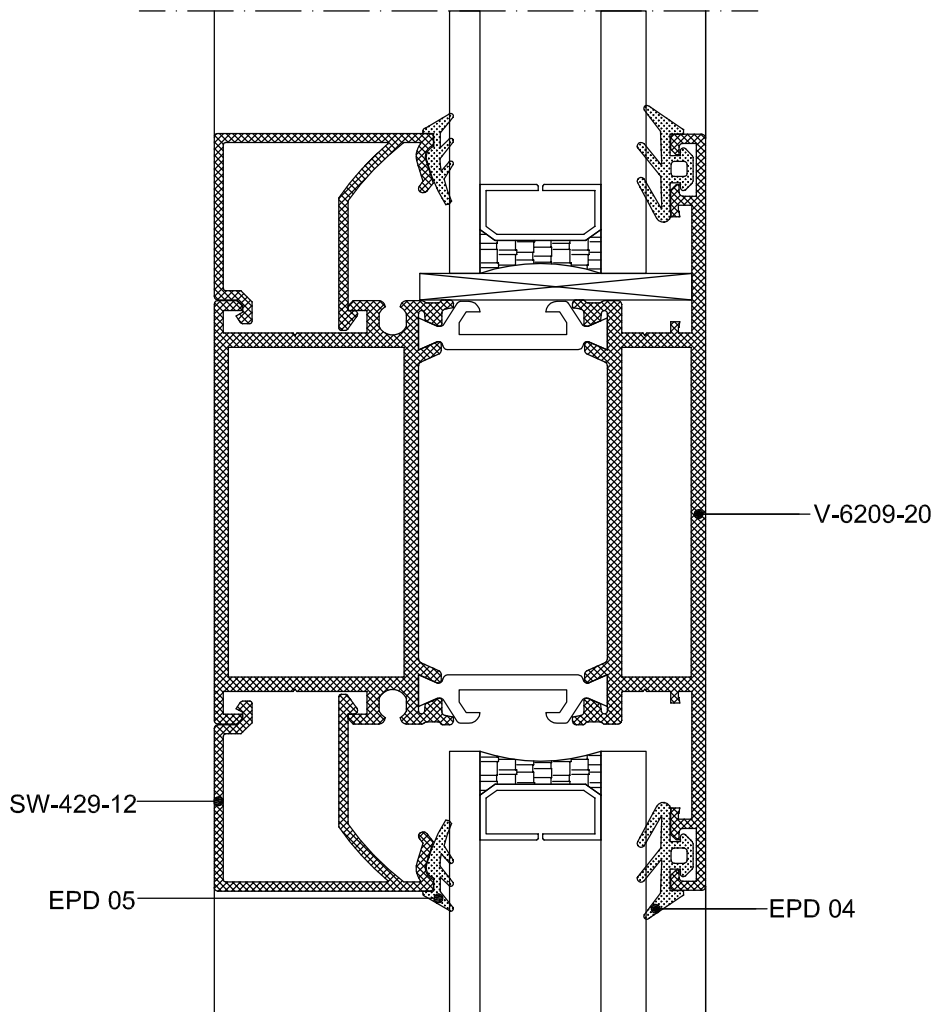

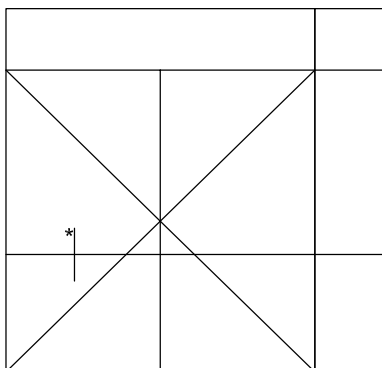

48

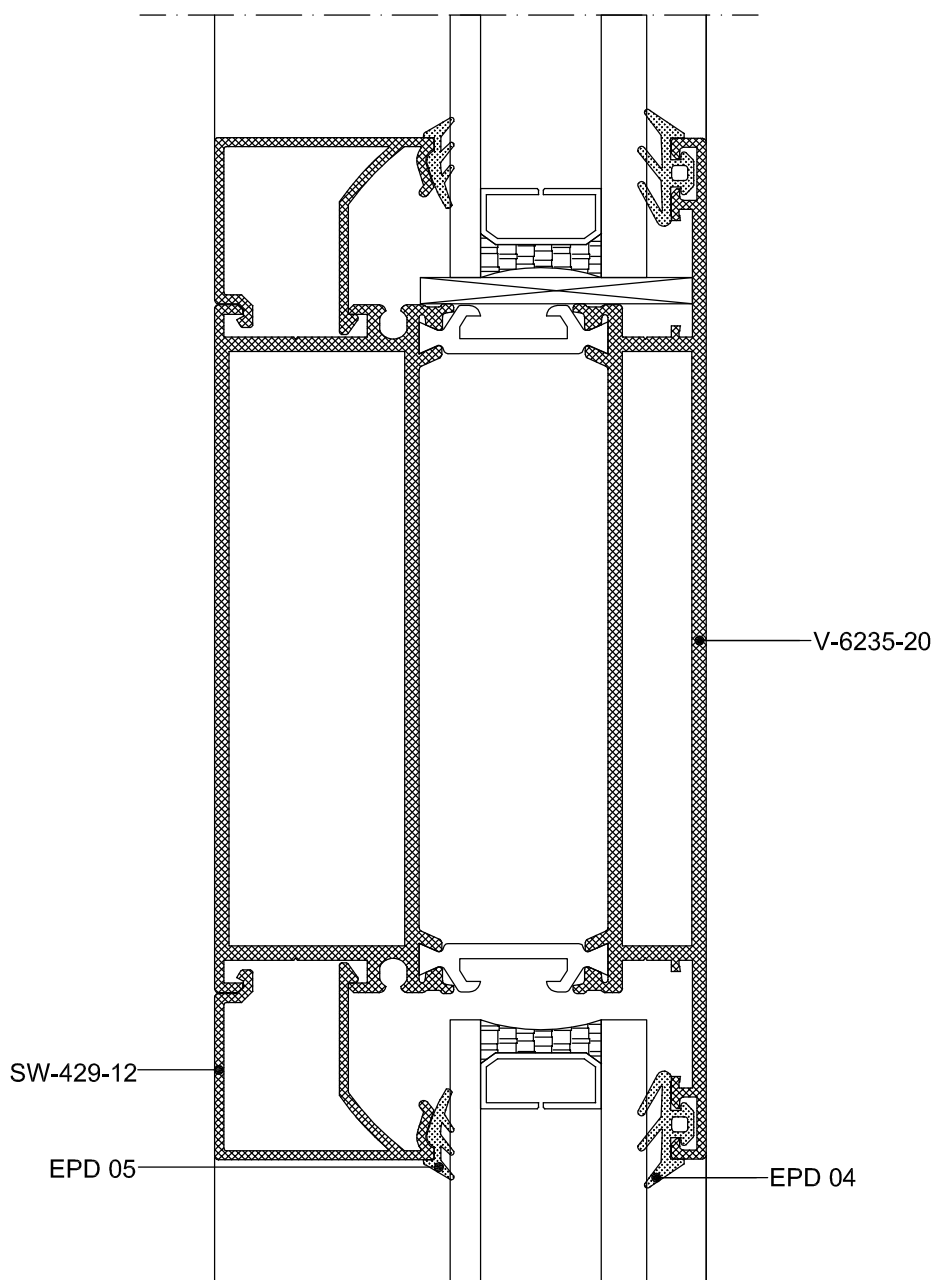

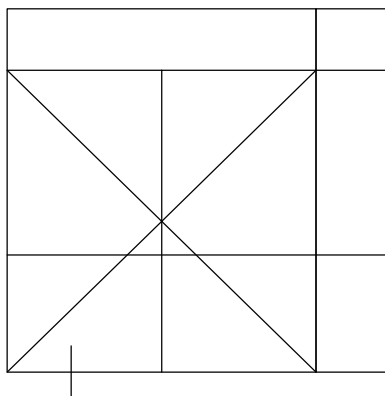

49

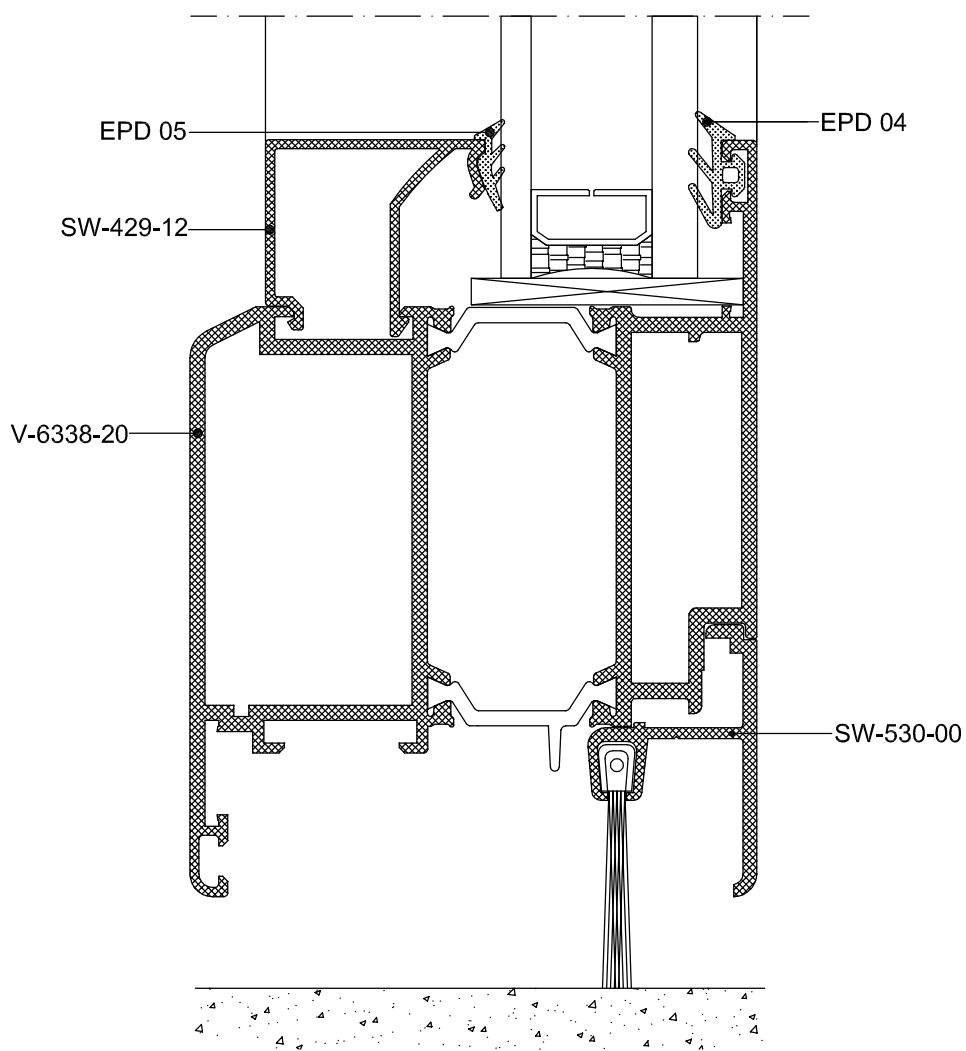

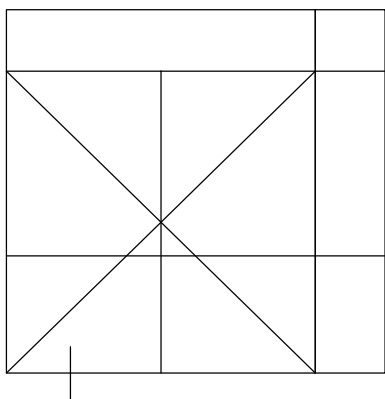

50

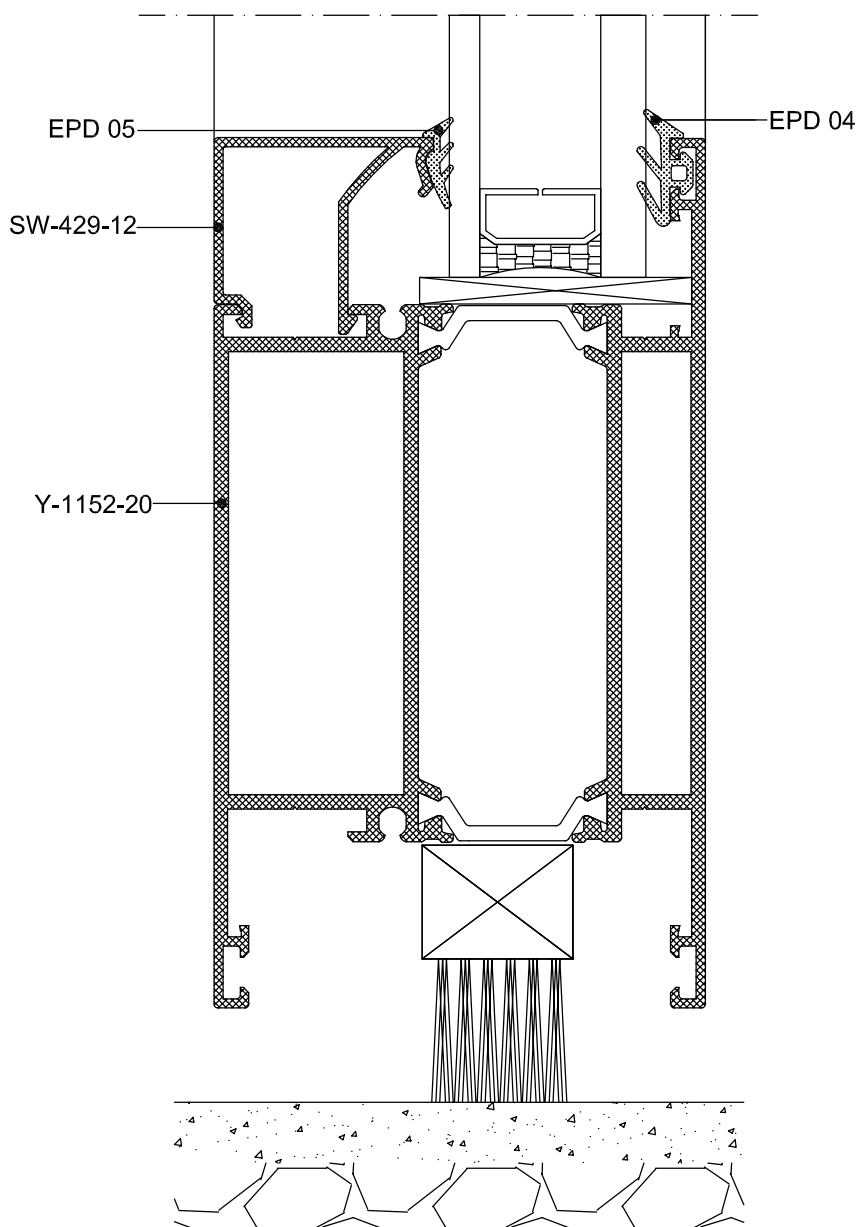

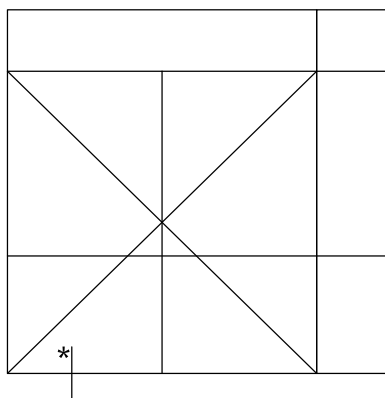

51

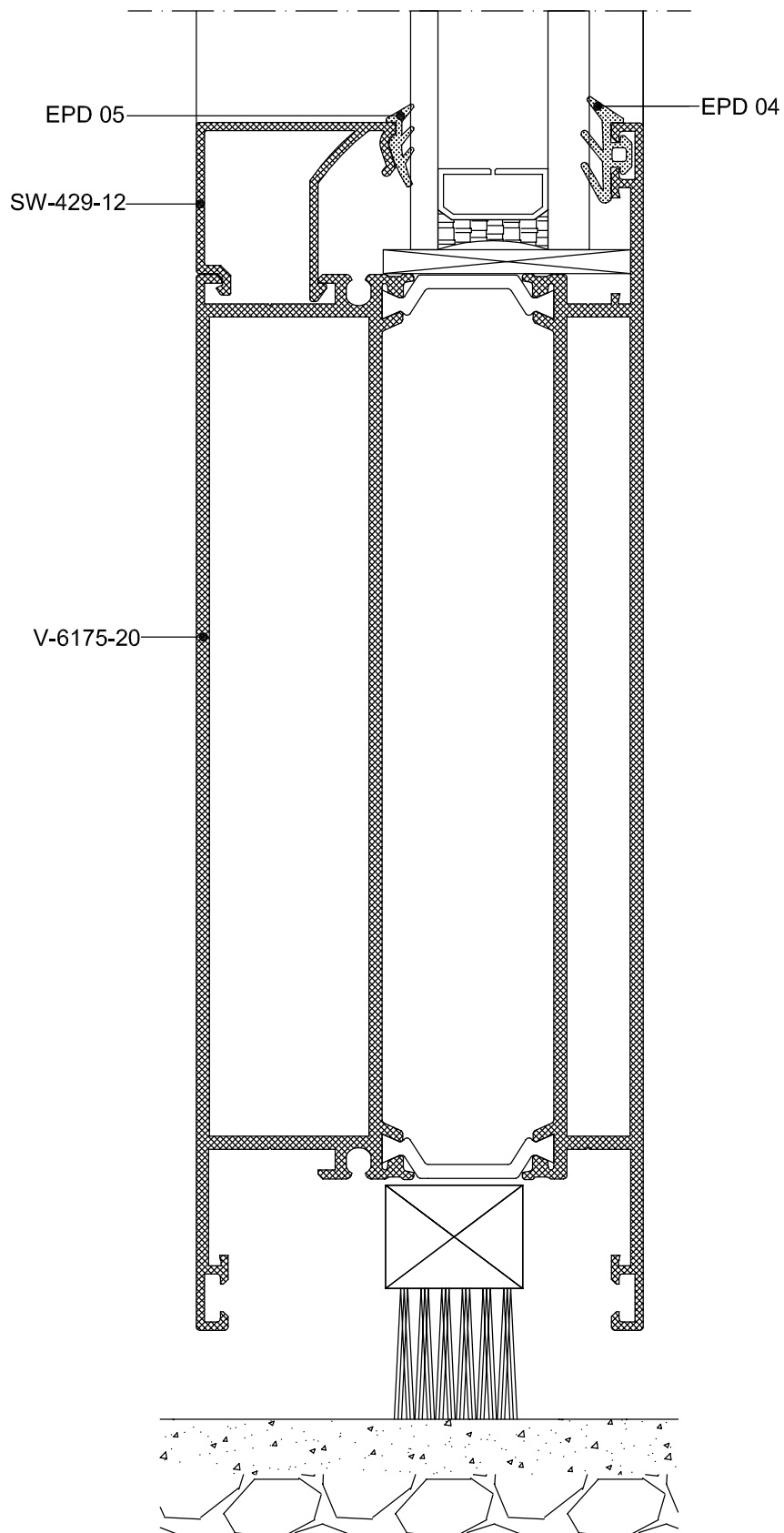

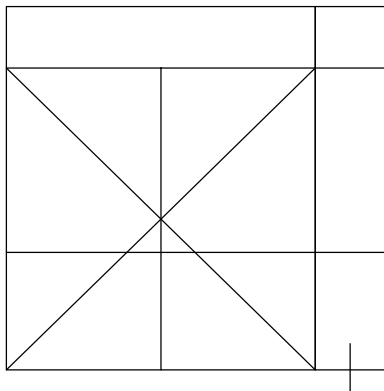

52

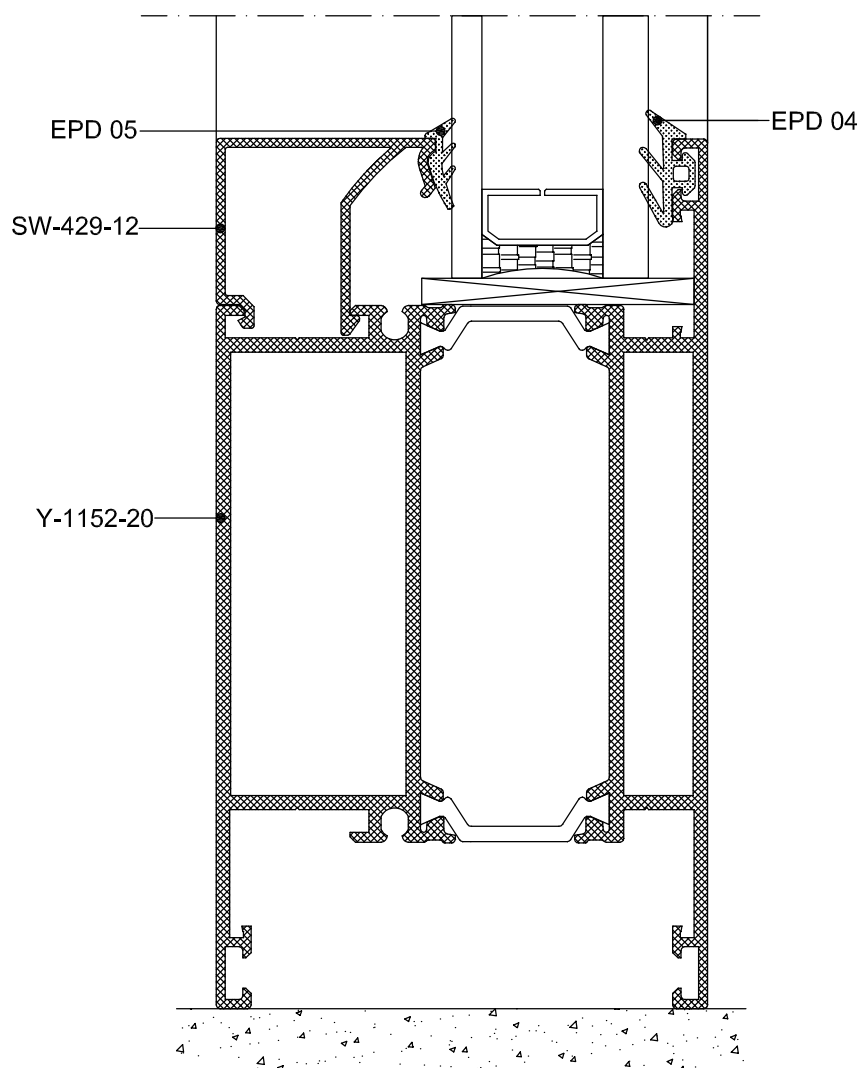

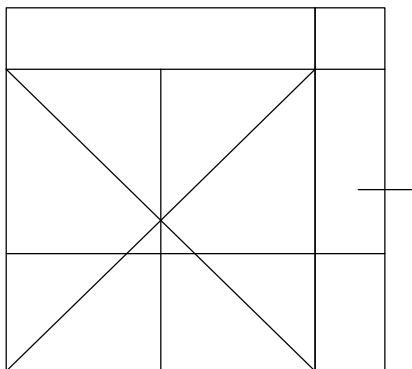

53

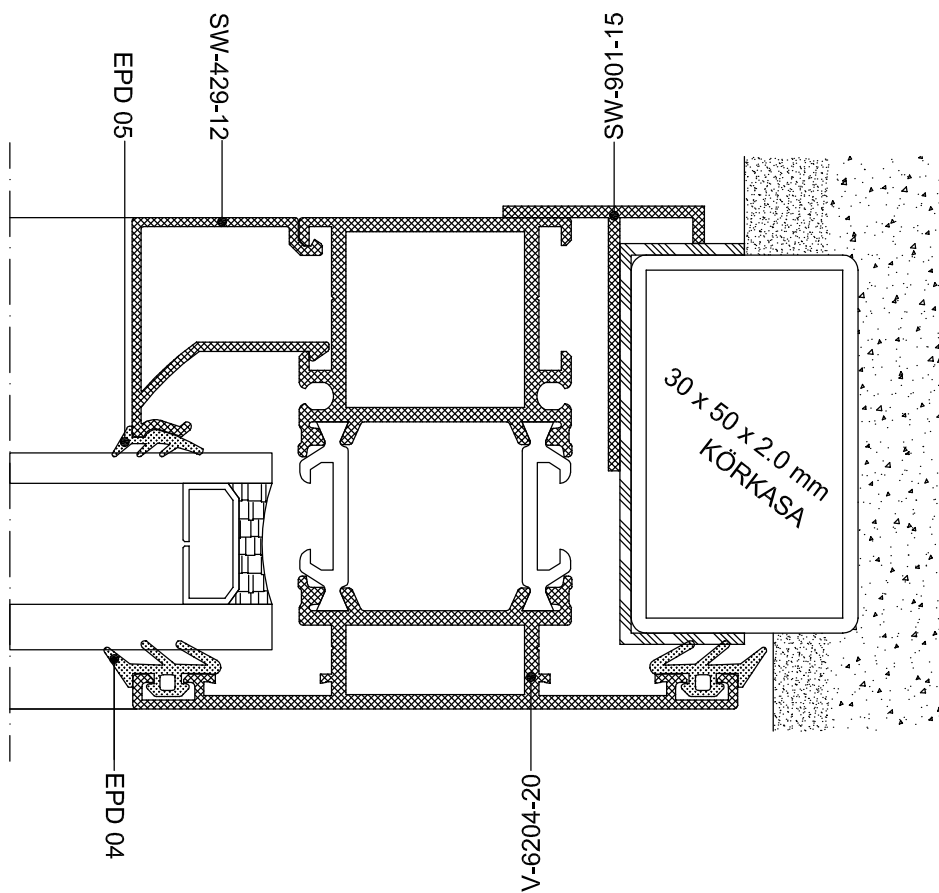



ALUFOUR

YALITIMLI DOĞRAMA SİSTEMİ



ALUFOUR

YALITIMLI DOĞRAMA SİSTEMİ