



YALITIMLI DOĞRAMA SİSTEMİ

**A
W
-
7
5**

ALUFOUR
DOĞRAMA SİSTEMLERİ



ALUFOUR

YALITIMLI DOĞRAMA SİSTEMİ

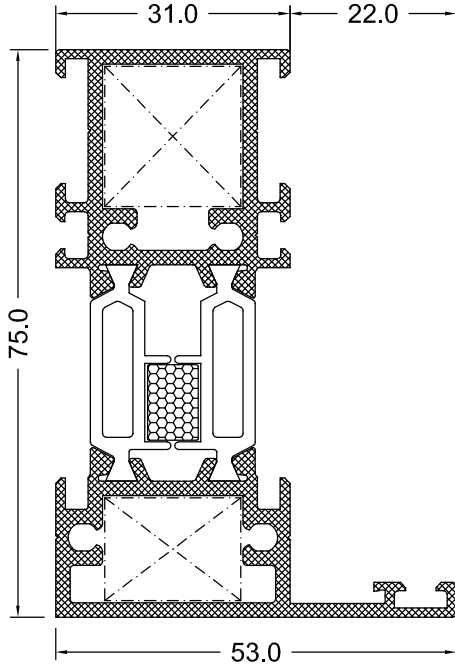

KASA PROFİLİ

PROFİL KODU	AĞIRLIK (kg/m)	KÖŞE GÖNYE	KESİM ÖLÇÜSÜ		I_x	I_y
			ÜST	ALT		
WL 02-20	1.797	TK-180	18.5 mm	13.6 mm	39.07	8.04

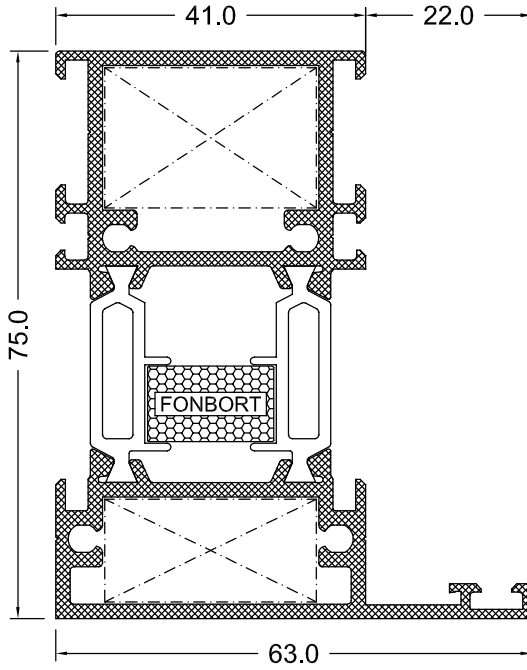

KASA PROFİLİ

PROFİL KODU	AĞIRLIK (kg/m)	KÖŞE GÖNYE	KESİM ÖLÇÜSÜ		I_x	I_y
			ÜST	ALT		
WL 04-20	2.003	TK-280	18.5 mm	13.6 mm	45.36	15.19

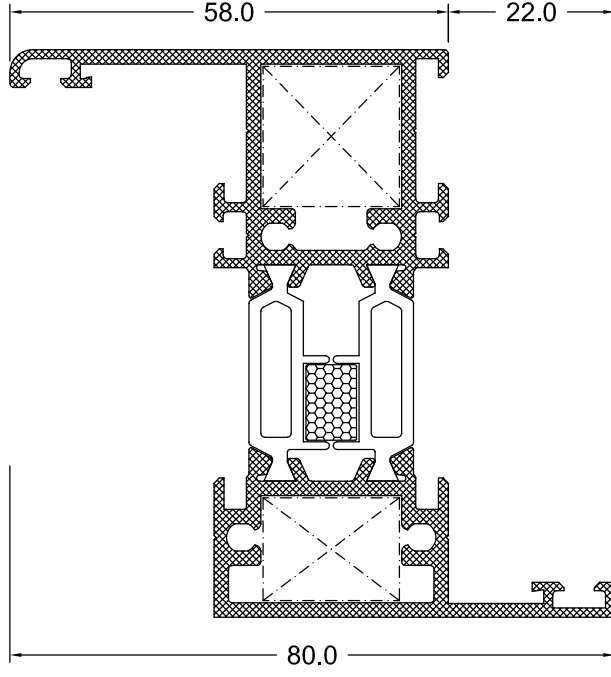

Z KASA PROFİLİ

PROFİL KODU	AĞIRLIK (kg/m)	KÖŞE GÖNYE	KESİM ÖLÇÜSÜ		I_x	I_y
			ÜST	ALT		
WL 09-20	1.955	TK-180	18.5 mm	13.6 mm	50.11	11.06

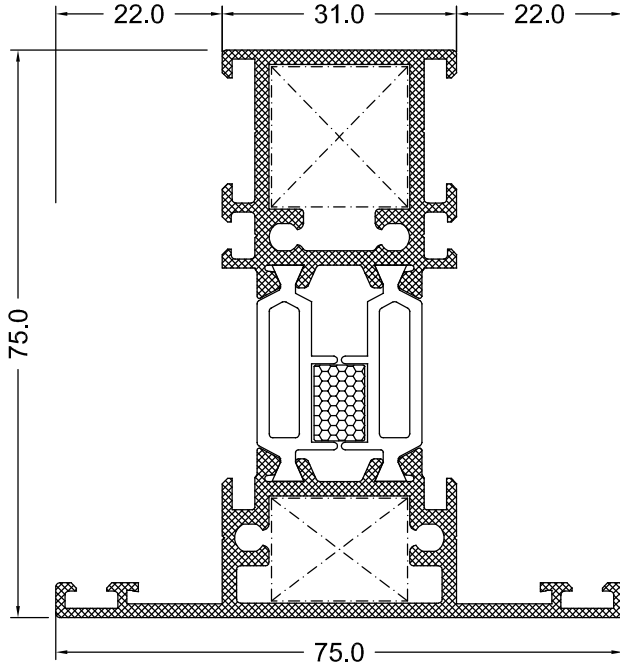

ORTA KAYIT PROFİLİ

PROFİL KODU	AĞIRLIK (kg/m)	KÖŞE GÖNYE	KESİM ÖLÇÜSÜ		I _x	I _y
			ÜST	ALT		
WL 12-20	1.925	TK-180	18.5 mm	13.6 mm	42.97	12.51

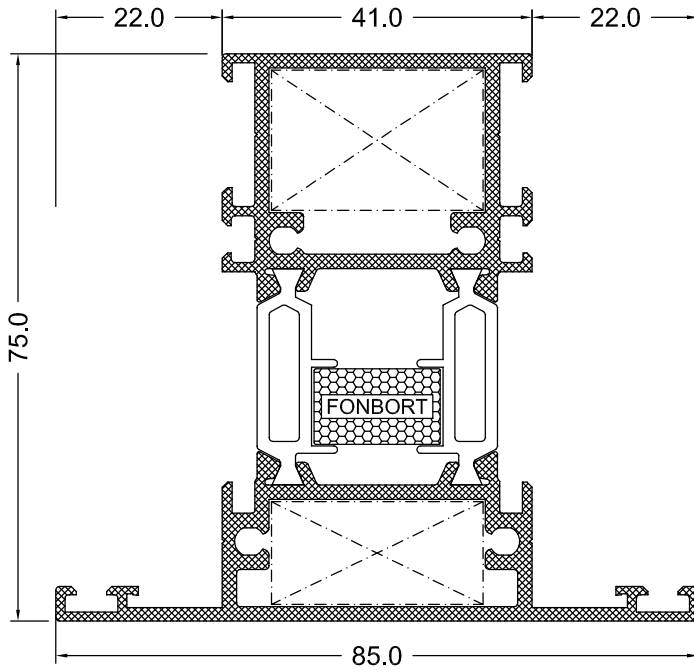

ORTA KAYIT PROFİLİ

PROFİL KODU	AĞIRLIK (kg/m)	KÖŞE GÖNYE	KESİM ÖLÇÜSÜ		I _x	I _y
			ÜST	ALT		
WL 14-20	2.131	TK-280	18.5 mm	13.6 mm	49.09	21.36

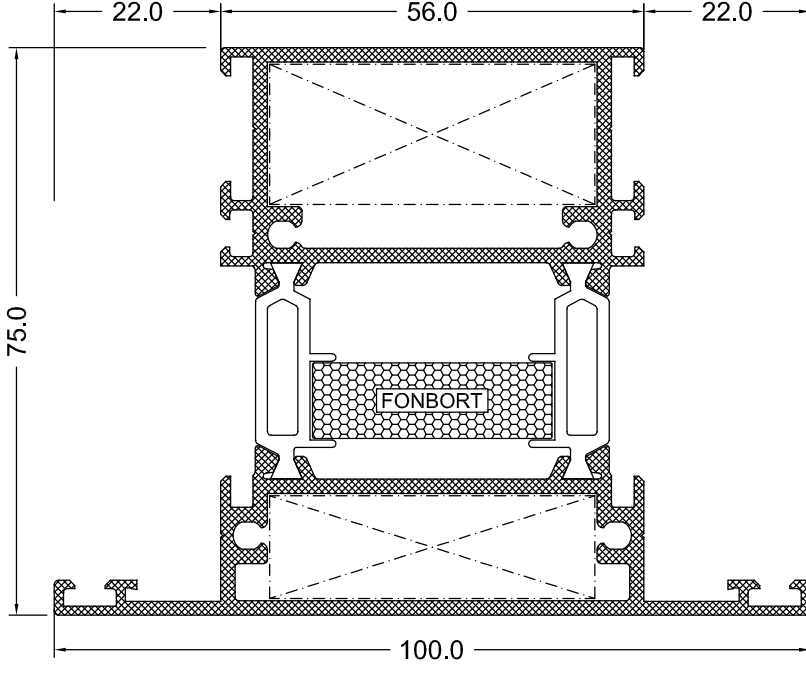

ORTA KAYIT PROFİLİ

PROFİL KODU	AĞIRLIK (kg/m)	KÖŞE GÖNYE	KESİM ÖLÇÜSÜ		I_x	I_y
			ÜST	ALT		
WL 18-20	2.440	TK-430	18.5 mm	13.6 mm	58.23	41.14

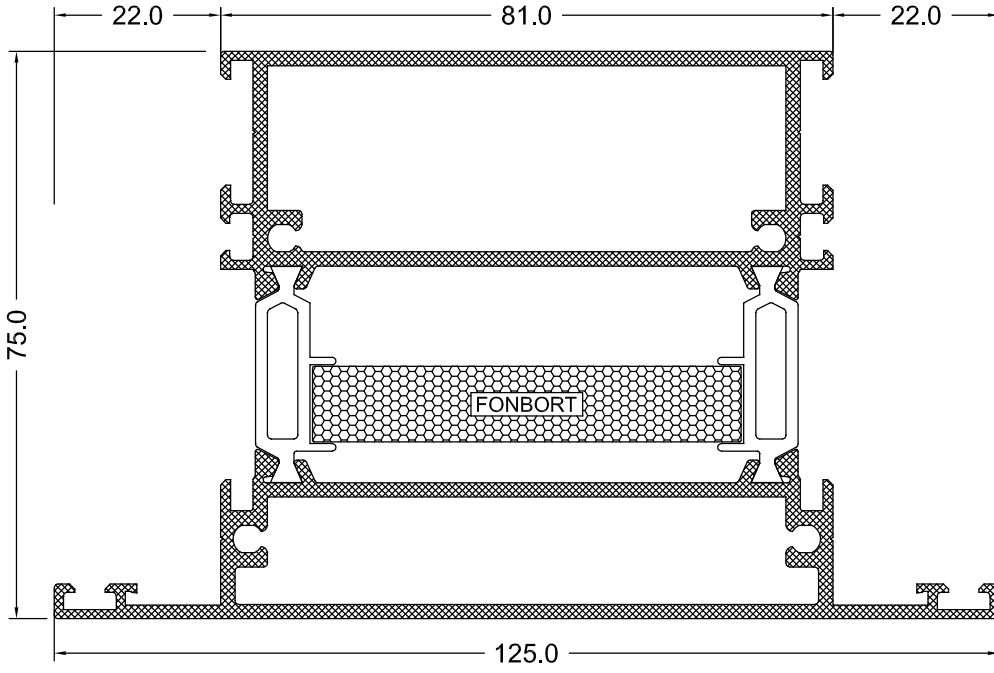

ORTA KAYIT PROFİLİ

PROFİL KODU	AĞIRLIK (kg/m)	KÖŞE GÖNYE	KESİM ÖLÇÜSÜ		I_x	I_y
			ÜST	ALT		
WL 22-20	2.955	---	---	---	73.41	94.58

ETEK PROFİLİ

PROFİL KODU	AĞIRLIK (kg/m)	KÖŞE GÖNYE	KESİM ÖLÇÜSÜ		I_x	I_y
			ÜST	ALT		
WL 70-20	3.613	---	---	---	-	-

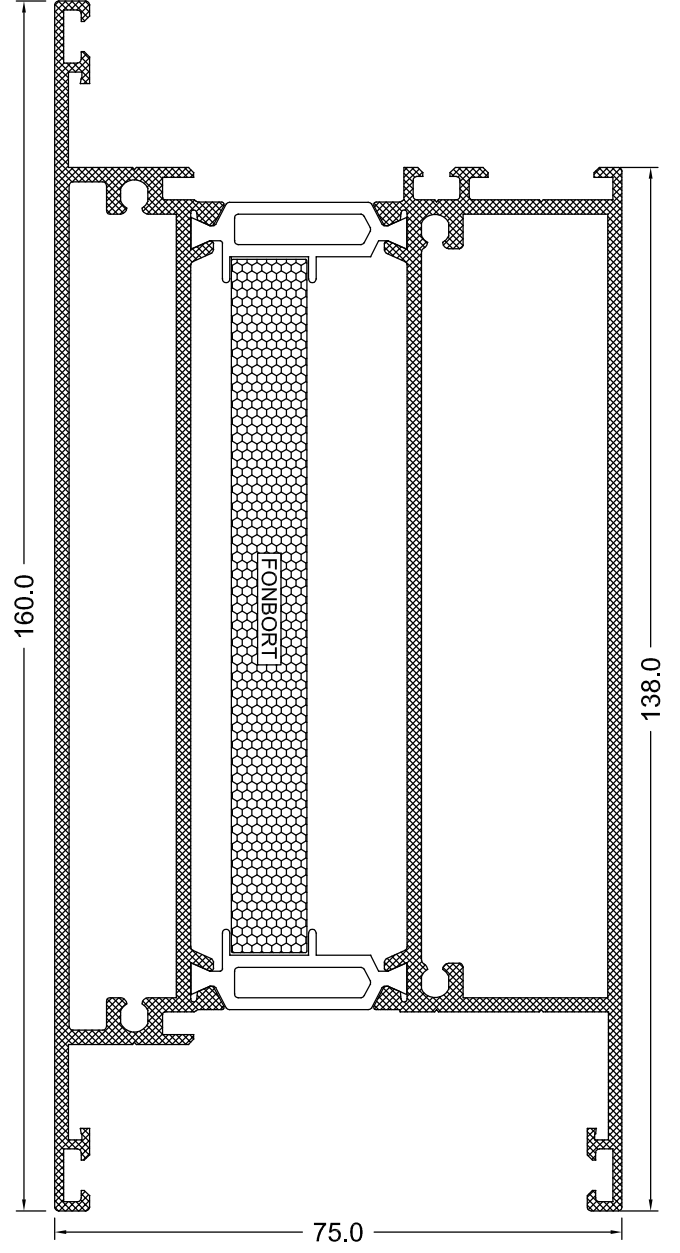
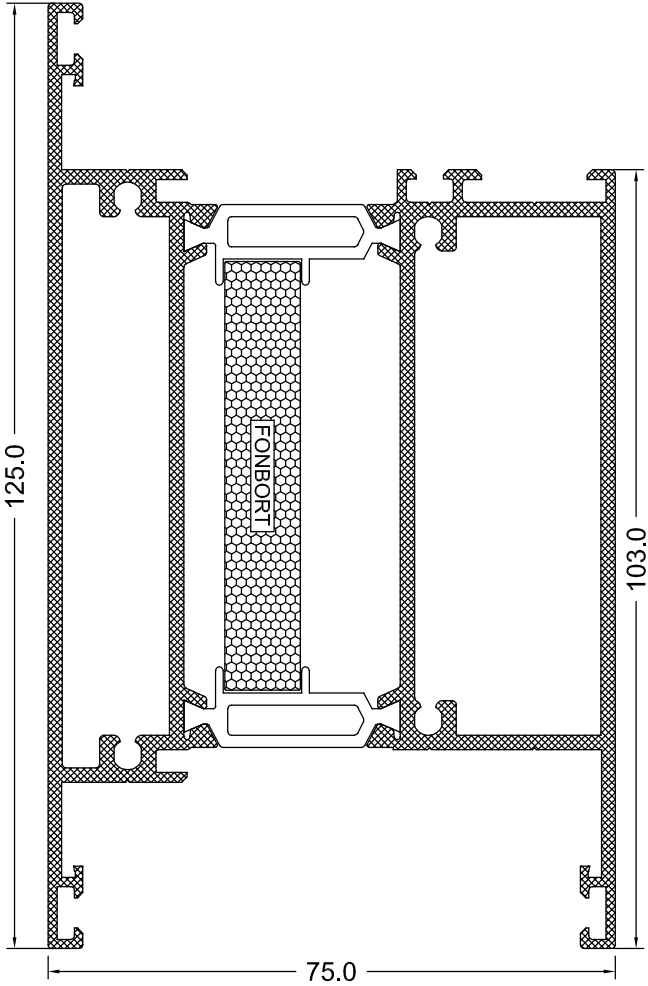

ETEK PROFİLİ

PROFİL KODU	AĞIRLIK (kg/m)	KÖŞE GÖNYE	KESİM ÖLÇÜSÜ		I_x	I_y
			ÜST	ALT		
WL 71-20	2.891	---	---	---	-	-

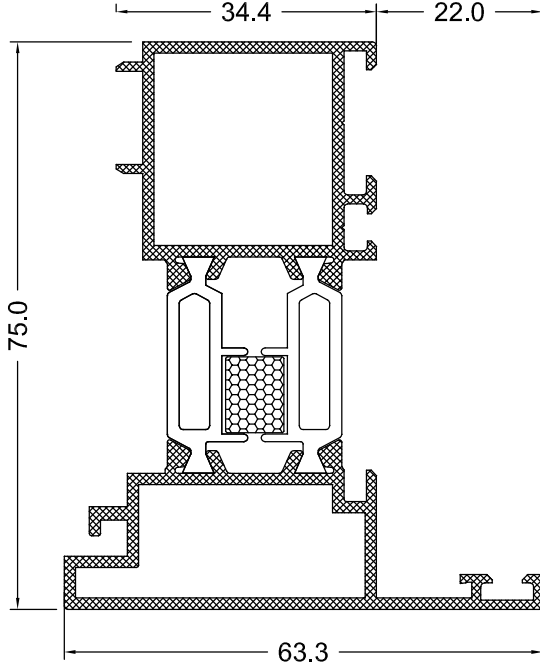

ÇİFT KANAT ADAPTÖRÜ

PROFİL KODU	AĞIRLIK (kg/m)
WL 50-15	1.436

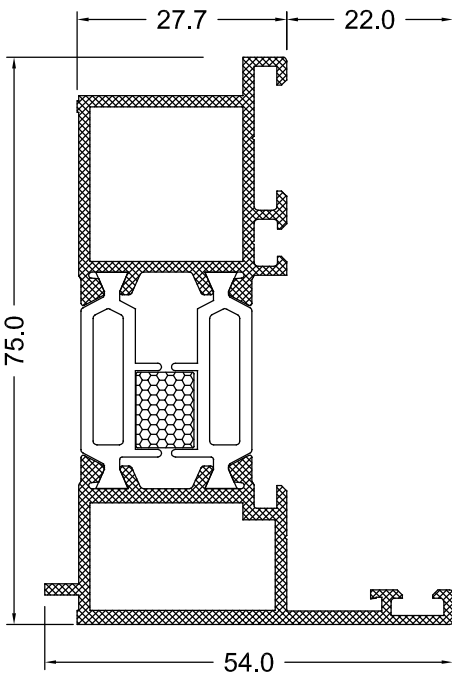

DIŞA AÇILIR KAPI ADAPTÖRÜ

PROFİL KODU	AĞIRLIK (kg/m)
WL 51-15	1.432

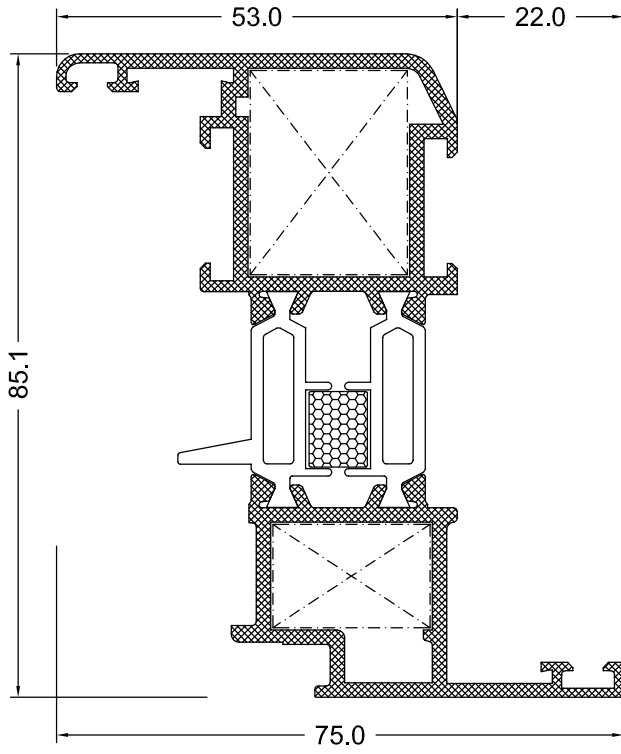

HEMYÜZ KANAT PROFİLİ

PROFİL KODU	AĞIRLIK (kg/m)	KÖŞE GÖNYE	KESİM ÖLÇÜSÜ	
			ÜST	ALT
WL 32-20	1.940	TK-208	27.0 mm	13.7 mm

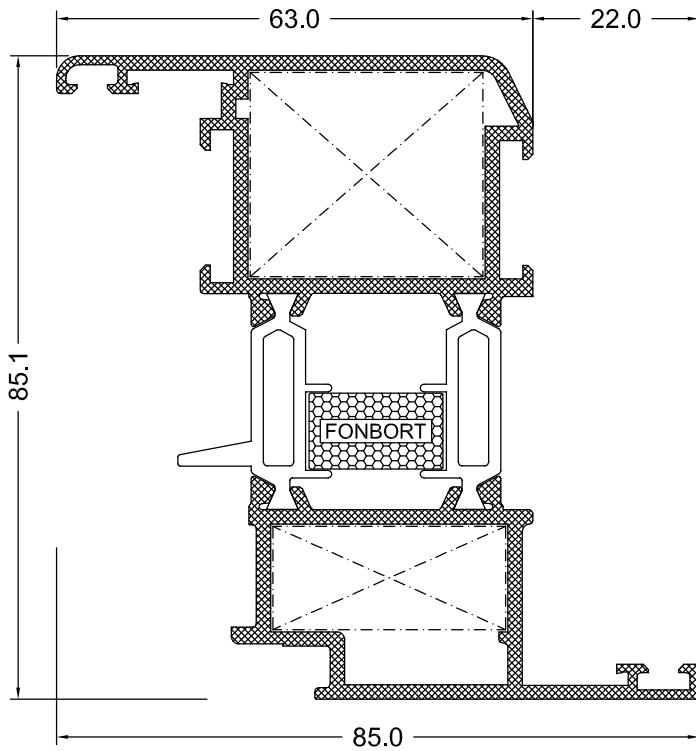

HEMYÜZ KANAT PROFİLİ

PROFİL KODU	AĞIRLIK (kg/m)	KÖŞE GÖNYE	KESİM ÖLÇÜSÜ	
			ÜST	ALT
WL 34-20	2.146	TK-308	27.0 mm	13.7 mm

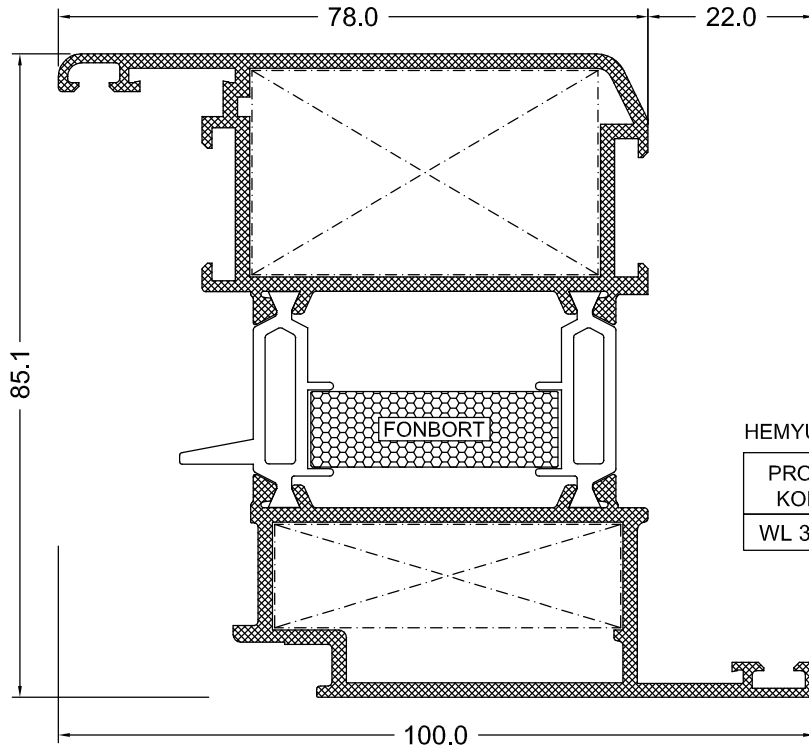

HEMYÜZ KAPI KANAT PROFİLİ

PROFİL KODU	AĞIRLIK (kg/m)	KÖŞE GÖNYE	KESİM ÖLÇÜSÜ	
			ÜST	ALT
WL 38-20	2.454	TK-458	27.0 mm	13.7 mm

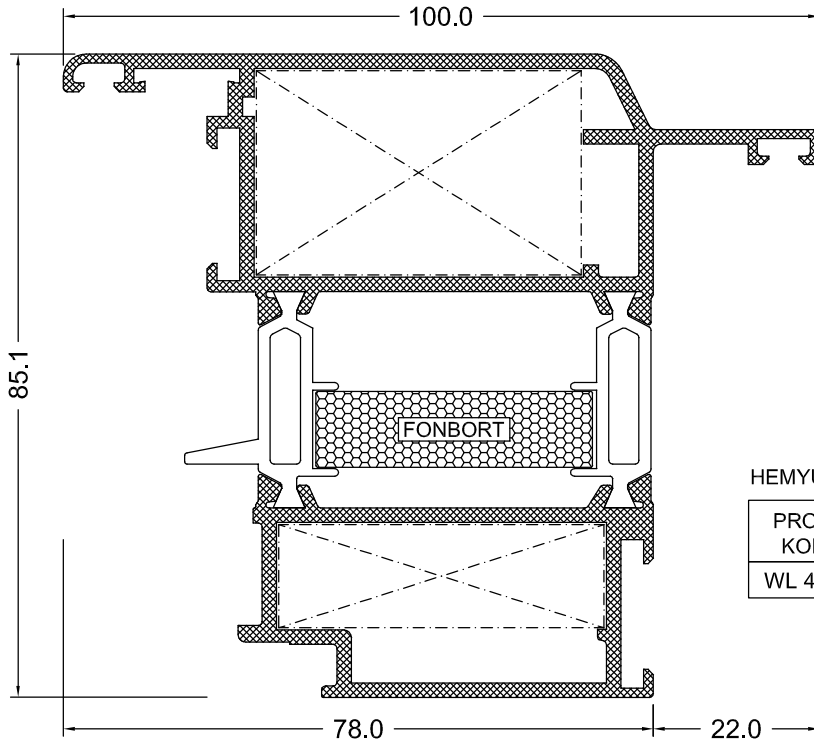

HEMYÜZ DIŞA AÇILIR KAPI KANAT PROFİLİ

PROFİL KODU	AĞIRLIK (kg/m)	KÖŞE GÖNYE	KESİM ÖLÇÜSÜ	
			ÜST	ALT
WL 45-20	2.498	TK-430	27.0 mm	13.7 mm

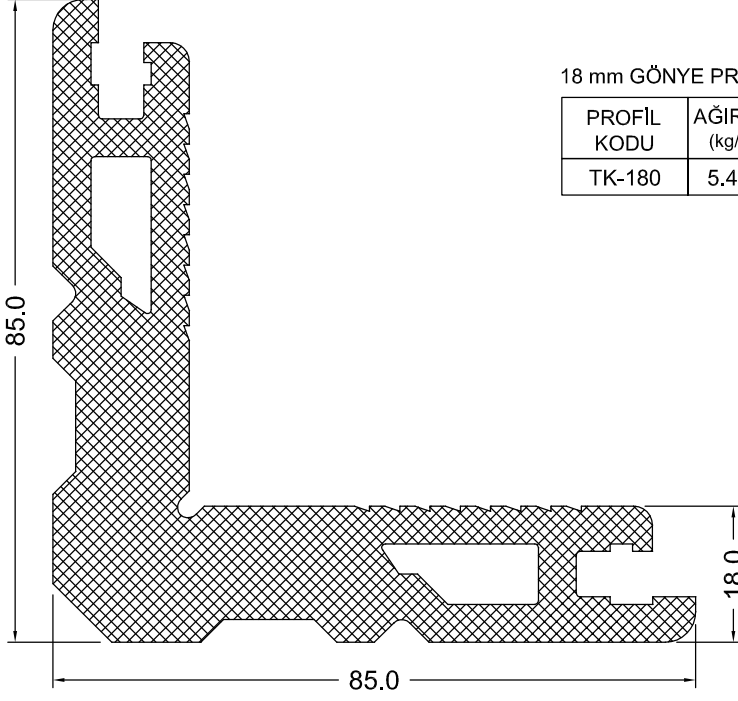

18 mm GÖNYE PROFİLİ

PROFİL KODU	AĞIRLIK (kg/m)	KÖŞE GÖNYE	KESİM ÖLÇÜSÜ		I _x	I _y
			ÜST	ALT		
TK-180	5,474	---	---	---	---	---

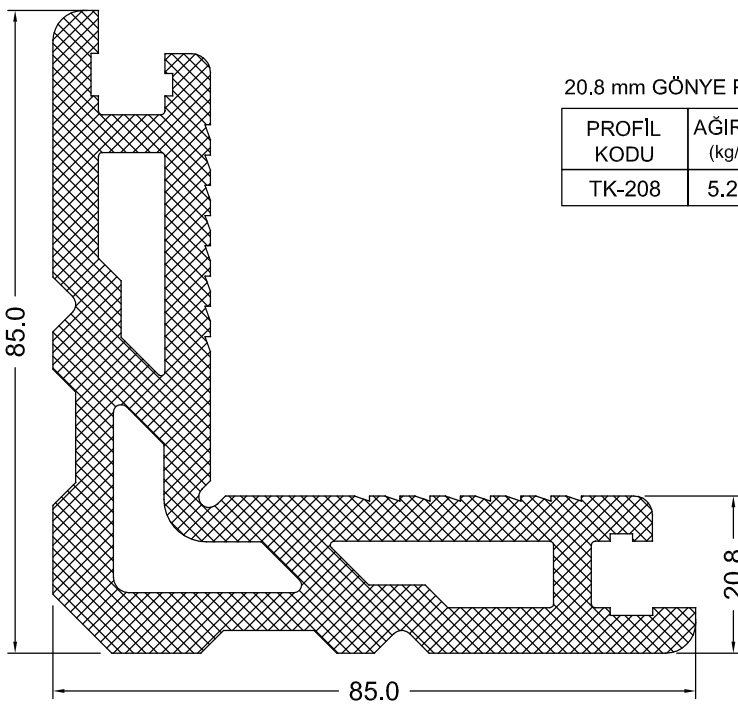

20.8 mm GÖNYE PROFİLİ

PROFİL KODU	AĞIRLIK (kg/m)	KÖŞE GÖNYE	KESİM ÖLÇÜSÜ		I _x	I _y
			ÜST	ALT		
TK-208	5,225	---	---	---	---	---

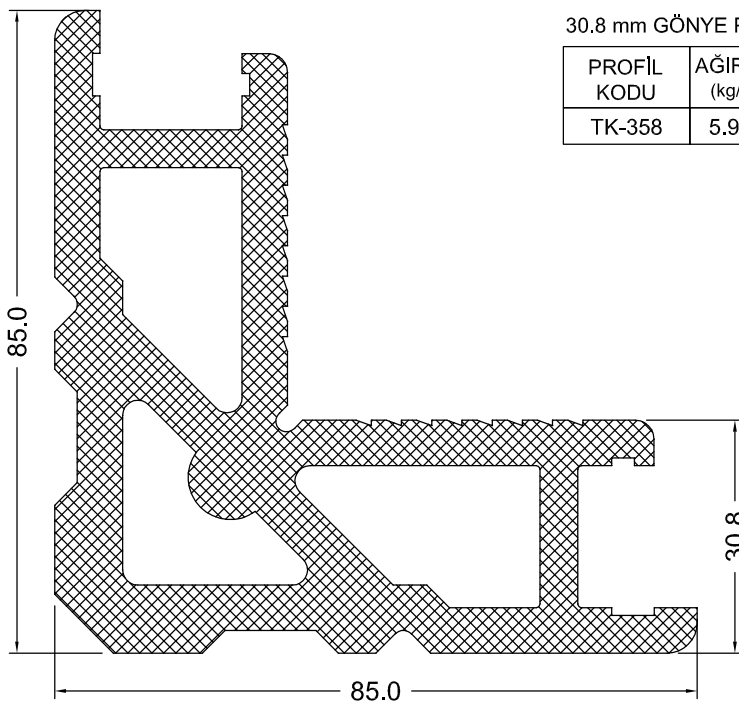
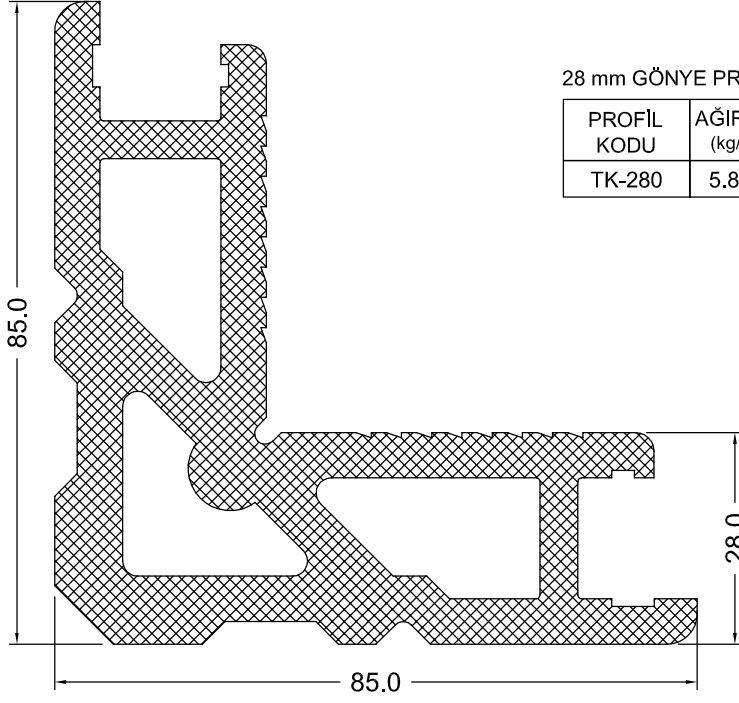

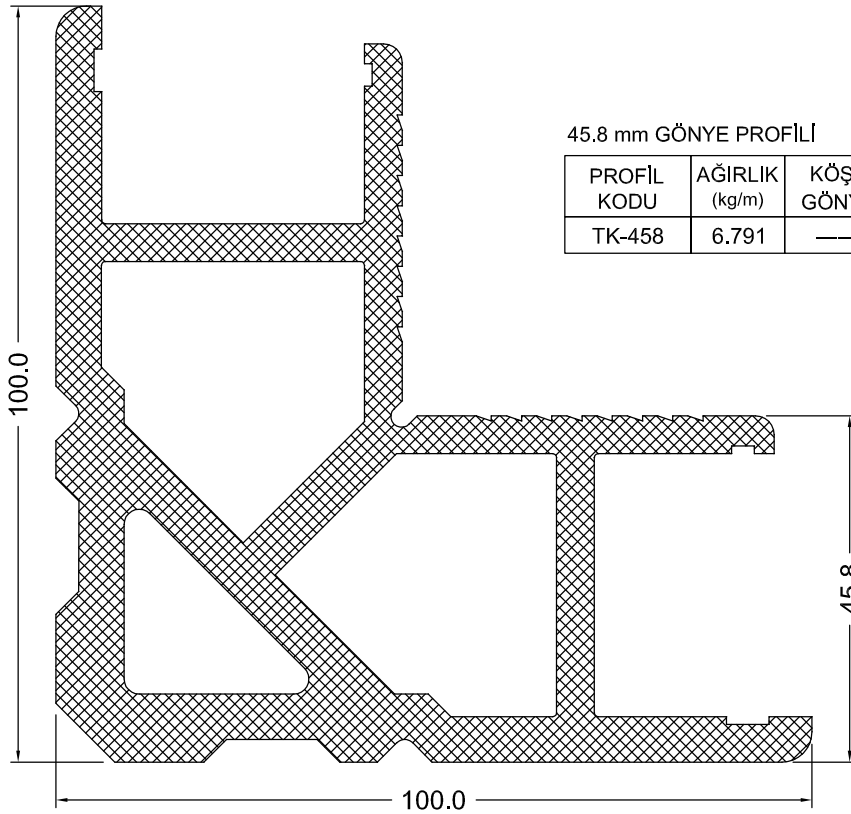
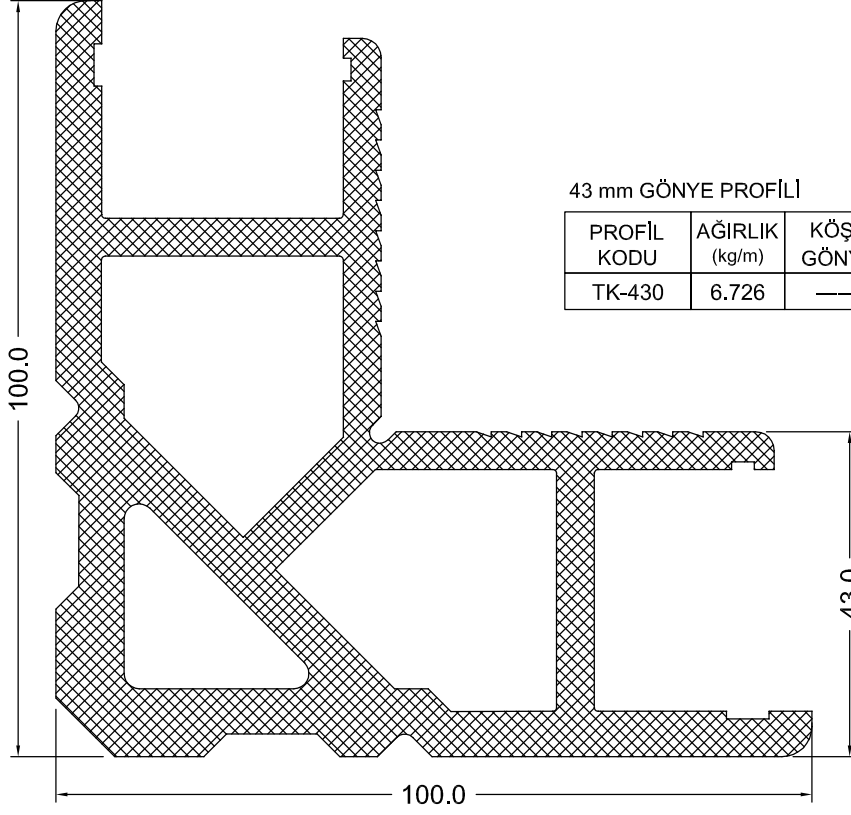

KAPILAR İÇİN FIRÇALIK PROFİLİ

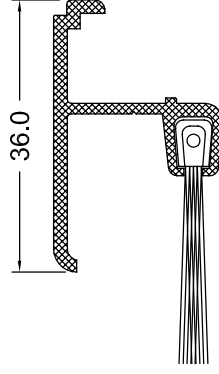

SW ZIVANA PROFİLİ

PROFİL KODU	AĞIRLIK (kg/m)
SW-530-00	0.344

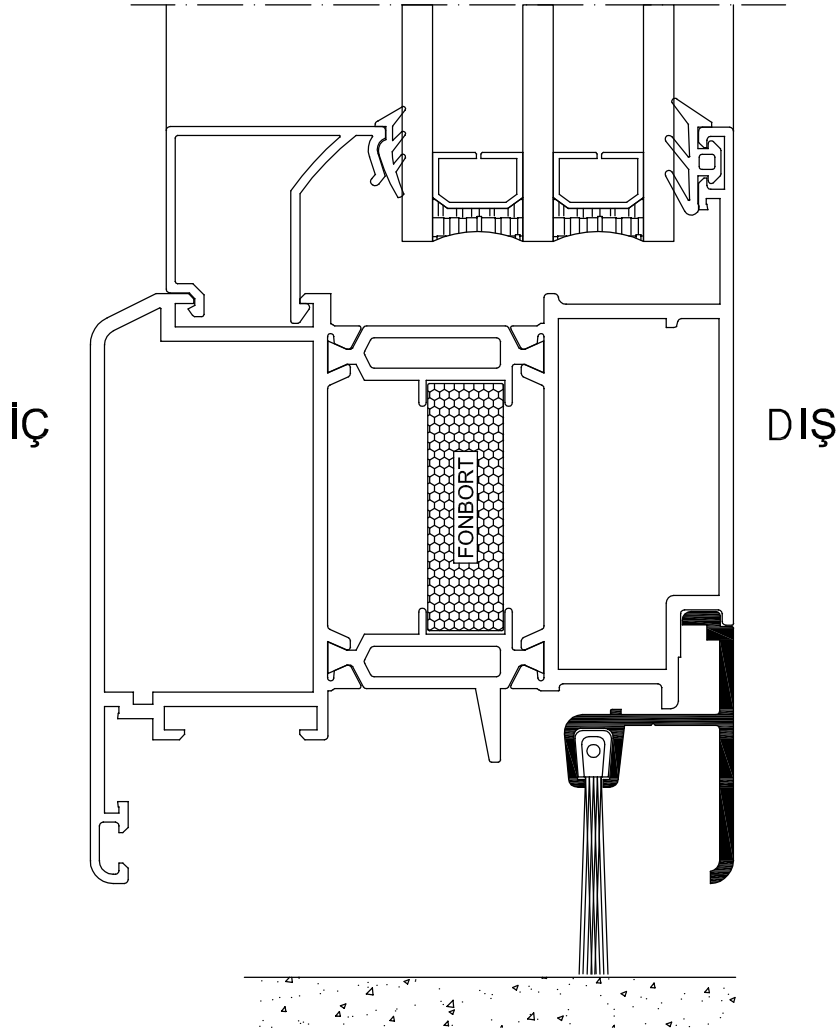

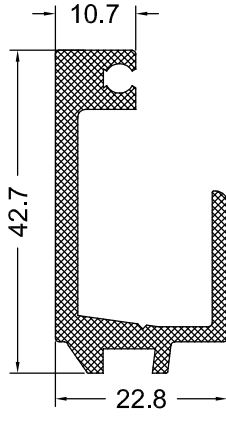

SW ZIVANA PROFİLİ

PROFİL KODU	AĞIRLIK (kg/m)
SW-541-00	0.742

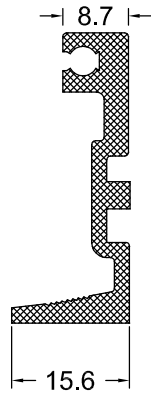

SW ZIVANA PROFİLİ

PROFİL KODU	AĞIRLIK (kg/m)
SW-542-00	0.499

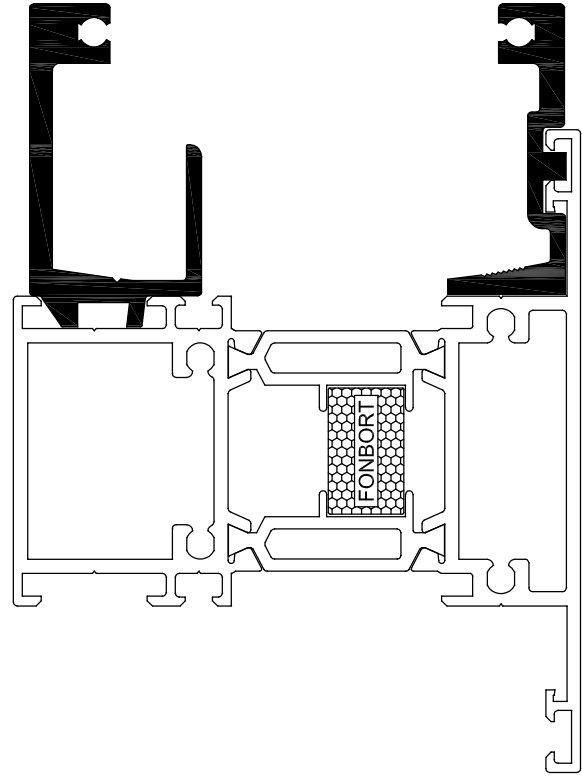

DAMLALIK PROFİLİ

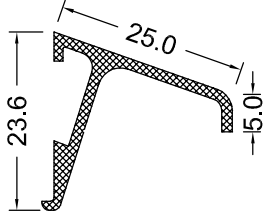

SW ZIVANA PROFİLİ

PROFİL KODU	AĞIRLIK (kg/m)
SW-532-00	0.217Kg/m

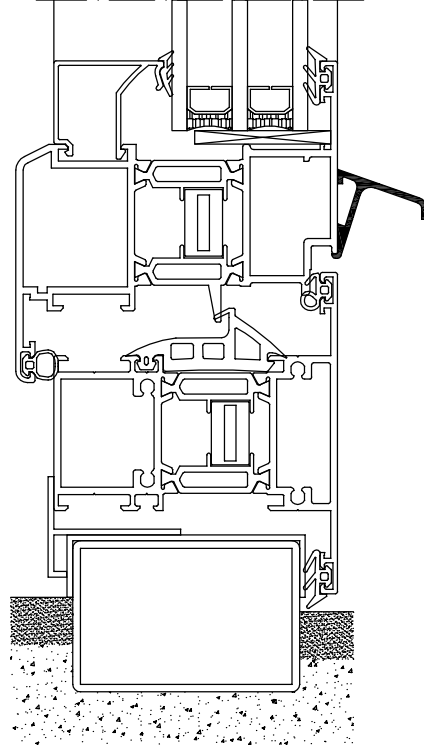

İSPANYOLET TİJ PROFİLİ

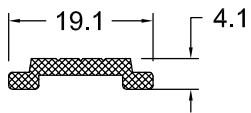

PROFİL KODU	AĞIRLIK (kg/m)
SW-533-00	0.124

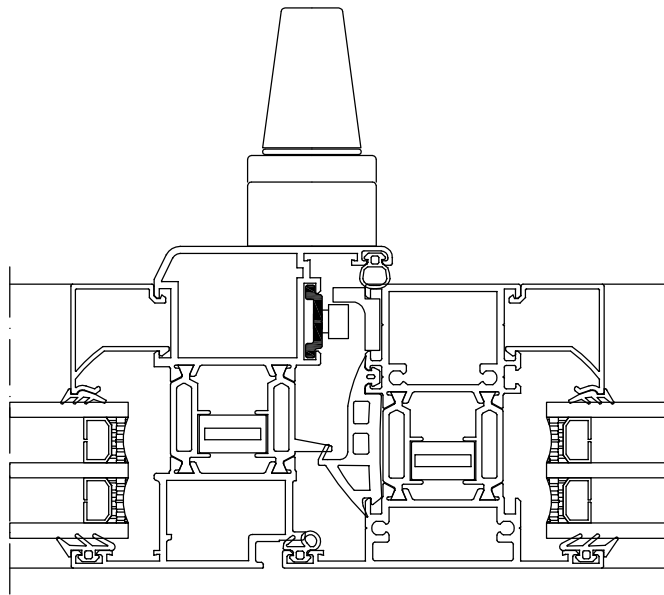

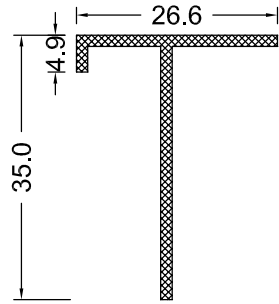

PROFİL KODU	AĞIRLIK (kg/m)
SW-901-15	0.257

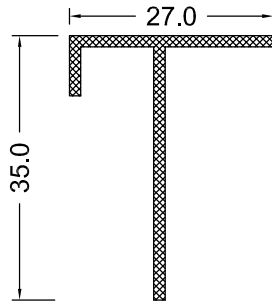

PROFİL KODU	AĞIRLIK (kg/m)
SW-902-15	0.271

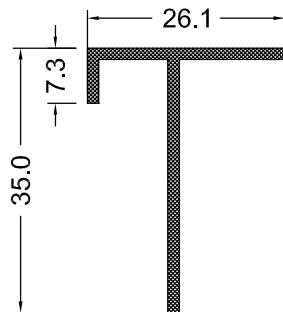

PROFİL KODU	AĞIRLIK (kg/m)
SW-903-15	0.265

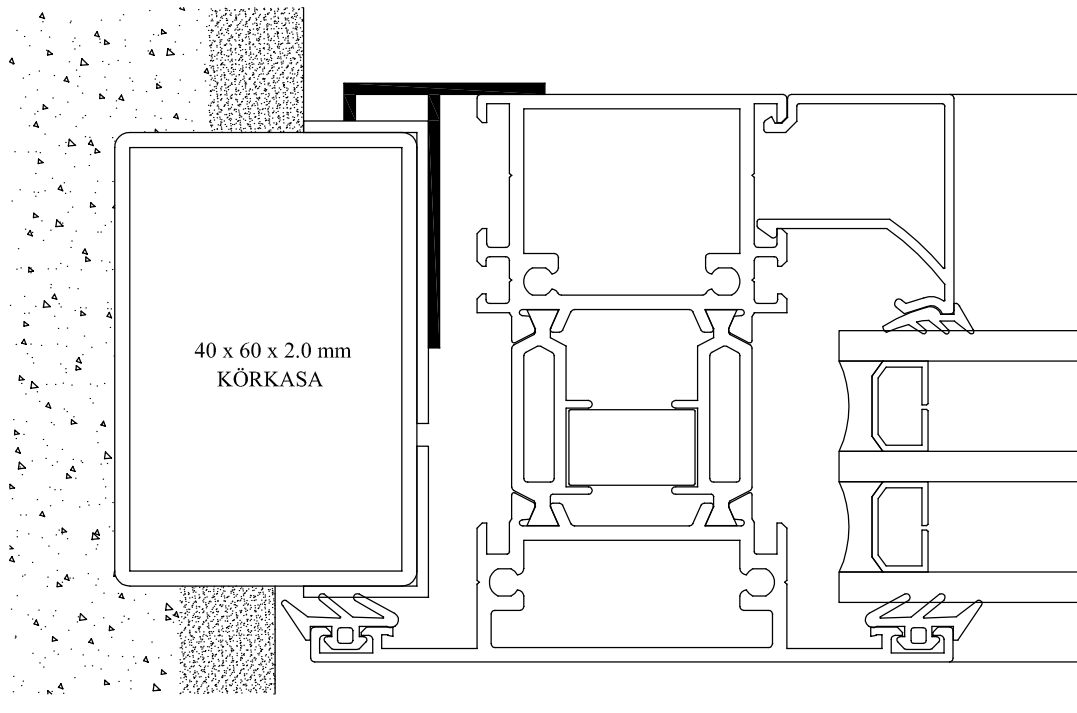

KAPATMA ÇİTALARI

BRÜT CAM BOŞLUKLARI

SW-441-12

0.341 Kg/m

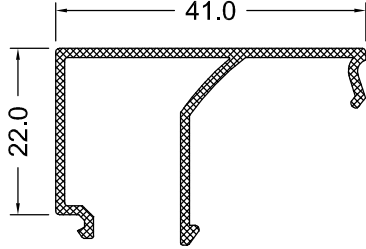

SW-441-15

0.420 Kg/m

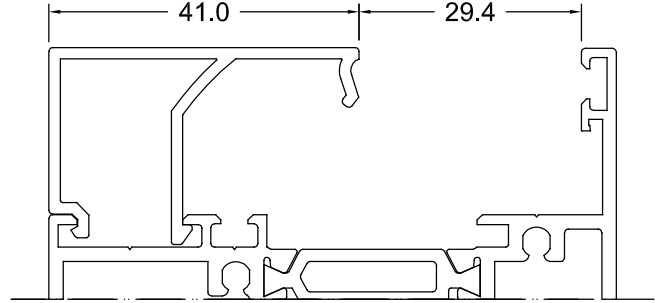

SW-439-12

0.336 Kg/m

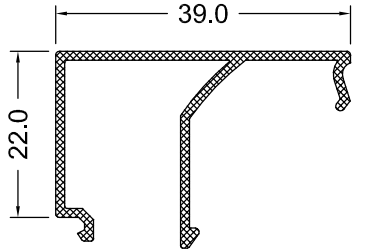

SW-439-15

0.412 Kg/m

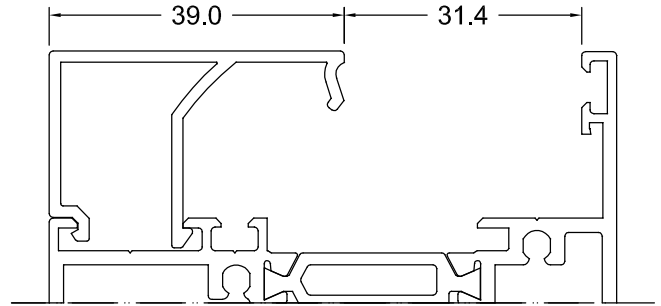

SW-437-12

0.328 Kg/m

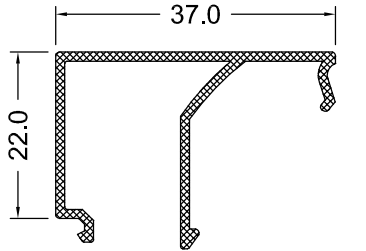

SW-437-15

0.404 Kg/m

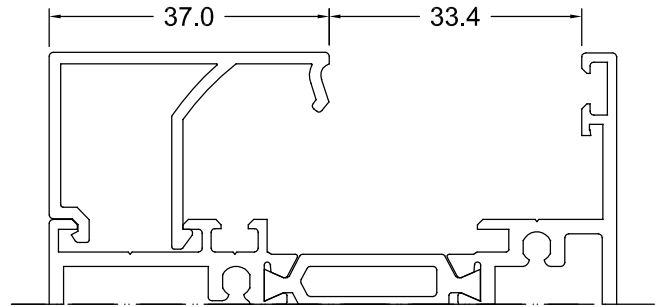

SW-435-12

0.322 Kg/m

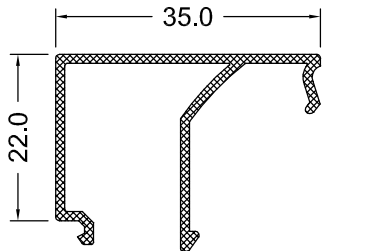

SW-435-15

0.396 Kg/m

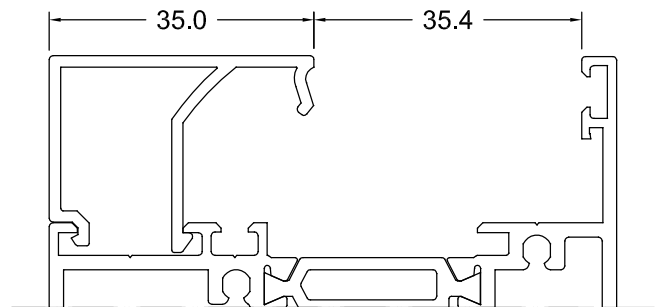

KAPATMA ÇİTALARI

BRÜT CAM BOŞLUKLARI

SW-433-12

0.314 Kg/m

SW-433-15

0.387 Kg/m

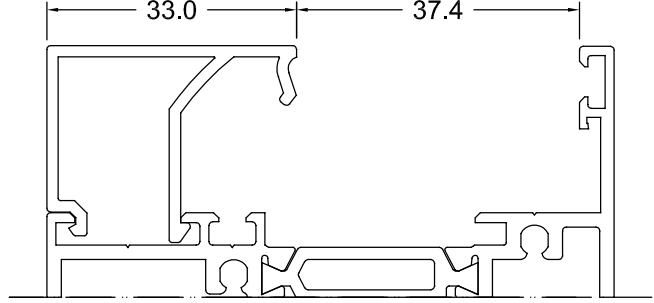
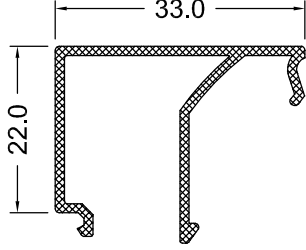

SW-431-12

0.309 Kg/m

SW-431-15

0.379 Kg/m

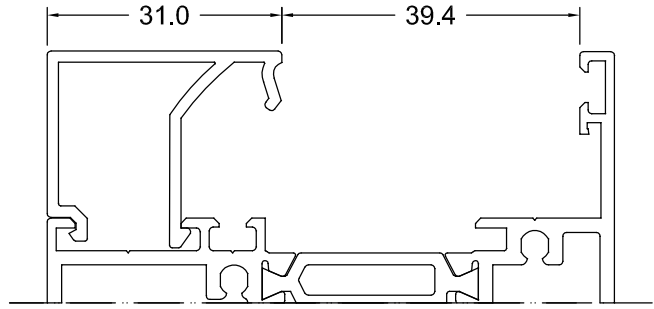
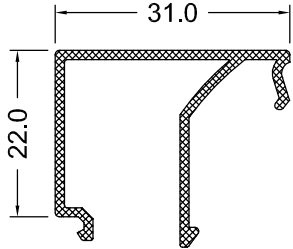

SW-429-12

0.303 Kg/m

SW-429-15

0.371 Kg/m

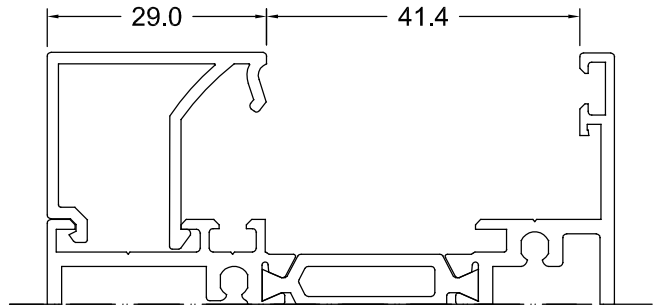
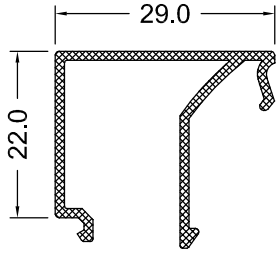

SW-427-12

0.295 Kg/m

SW-427-15

0.357 Kg/m

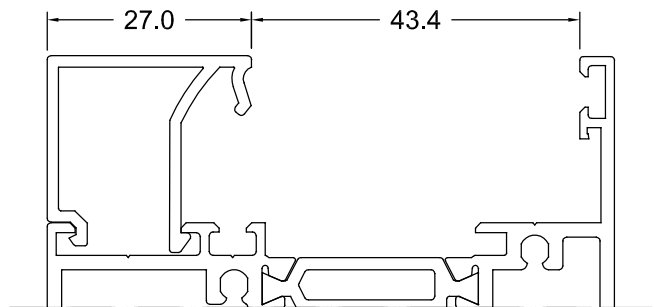
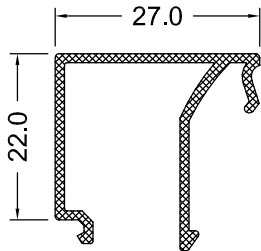

KAPATMA ÇİTALARI

BRÜT CAM BOŞLUKLARI

SW-425-12

0.290 Kg/m

SW-425-15

0.347 Kg/m

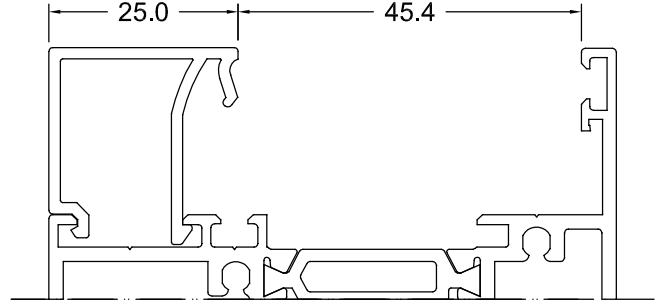
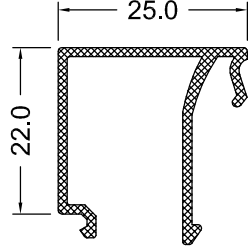

SW-423-12

0.279 Kg/m

SW-423-15

0.341 Kg/m

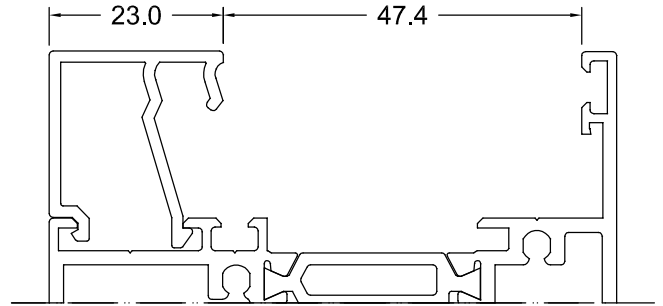
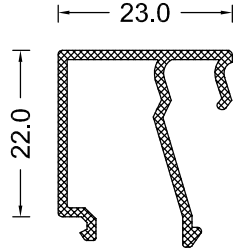

SW-421-12

0.271 Kg/m

SW-421-15

0.333 Kg/m

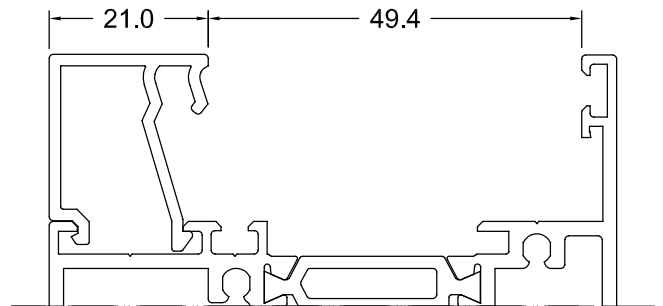
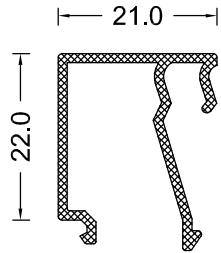

SW-419-12

0.274 Kg/m

SW-419-15

0.336 Kg/m

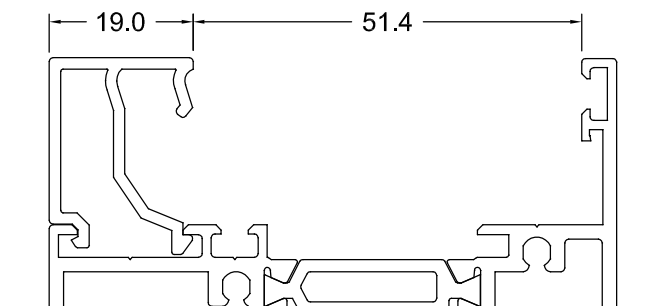
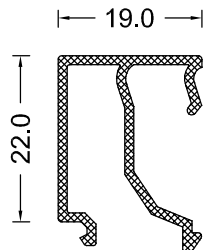

KAPATMA ÇİTALARI

BRÜT CAM BOŞLUKLARI

SW-417-12

0.268 Kg/m

SW-417-15

0.328 Kg/m

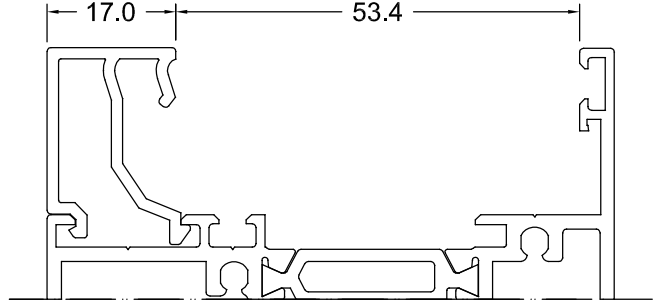
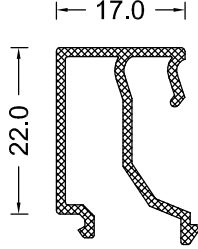

SW-415-12

0.236 Kg/m

SW-415-15

0.290 Kg/m

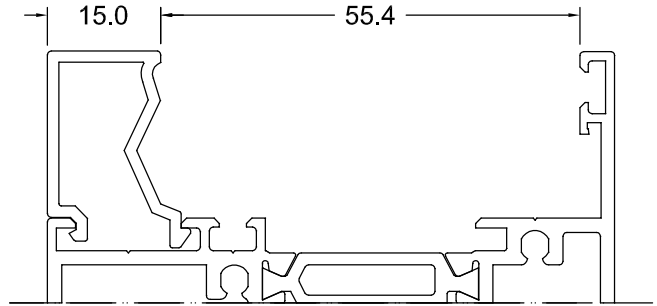
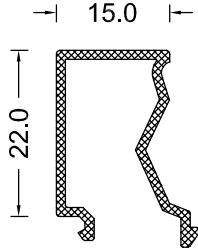

SW-413-12

0.230 Kg/m

SW-413-15

0.282 Kg/m

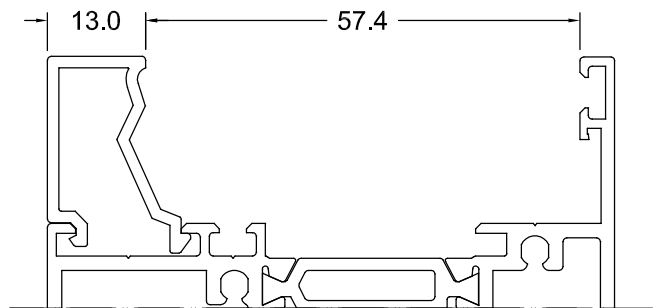
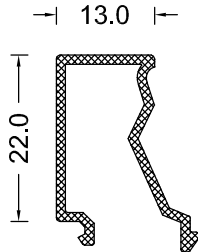

SW-410-12

0.225 Kg/m

SW-410-15

0.276 Kg/m

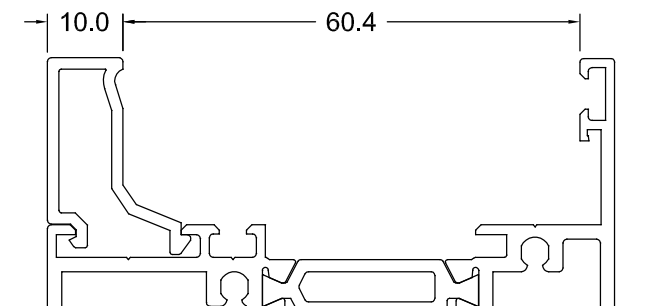
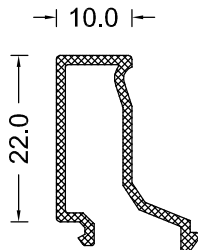

KAPATMA ÇİTASI

PROFİL KODU	AĞIRLIK (kg/m)
SW-405-14	0.198

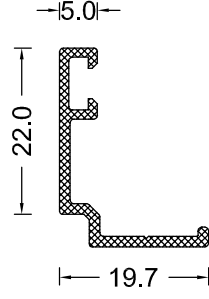

BRÜT CAM BOŞLUKLARI

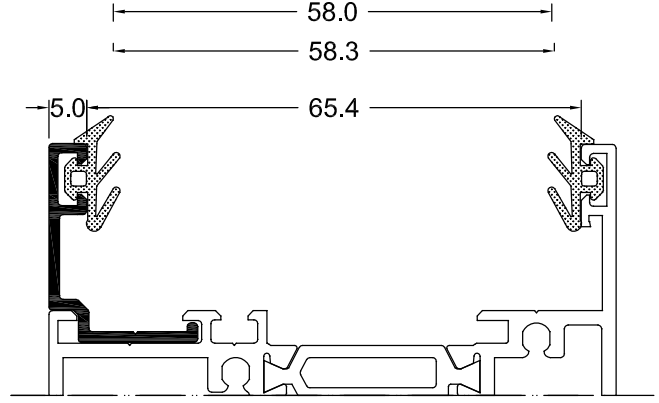

KİLİT KARŞILIĞI

PROFİL KODU	AĞIRLIK (kg/m)
SW-548-00	0.268

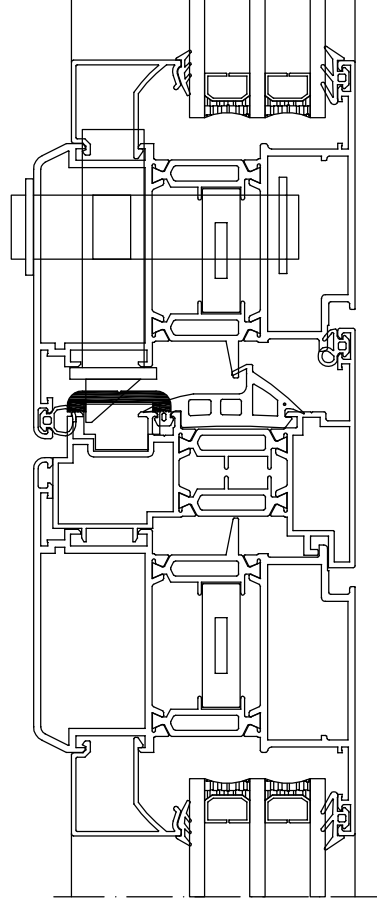
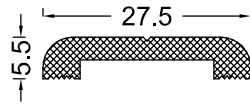

NET CAM BOŞLUKLARI

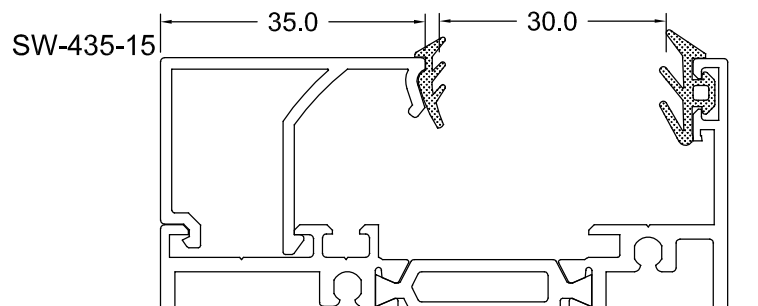
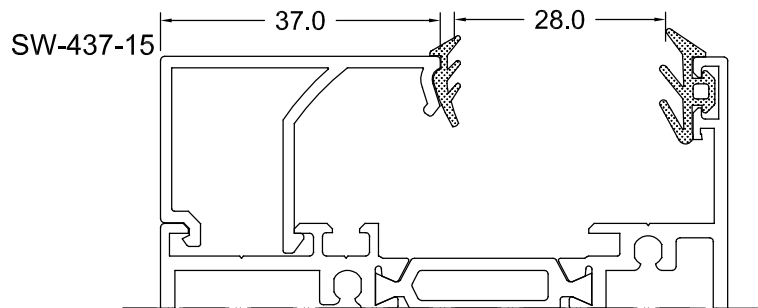
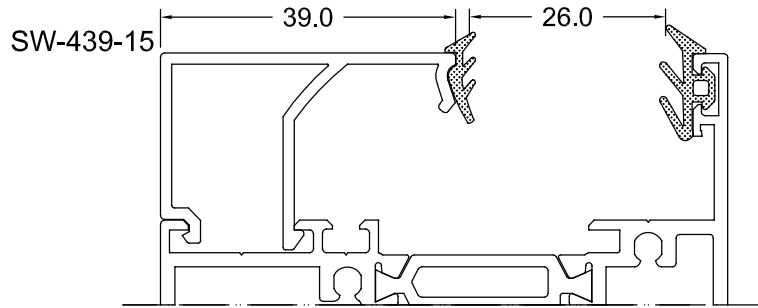
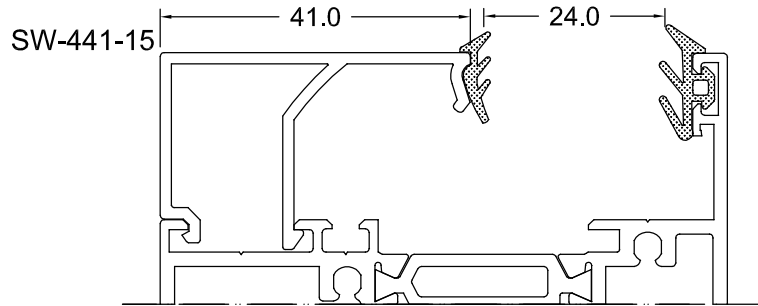

NET CAM BOŞLUKLARI

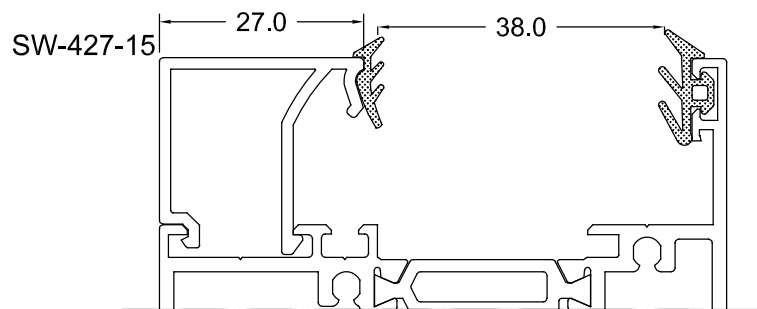
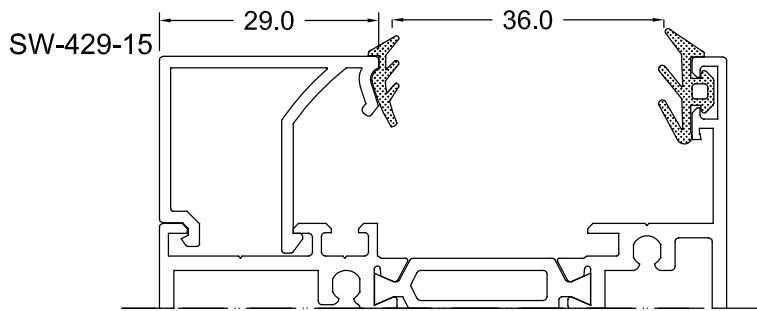
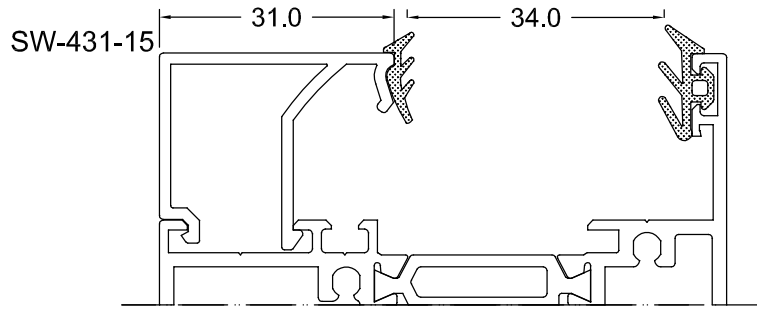
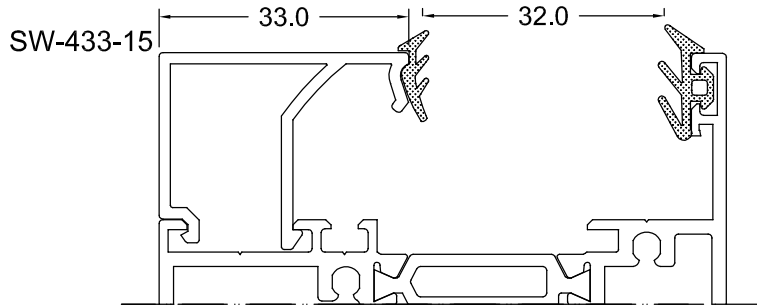

NET CAM BOŞLUKLARI

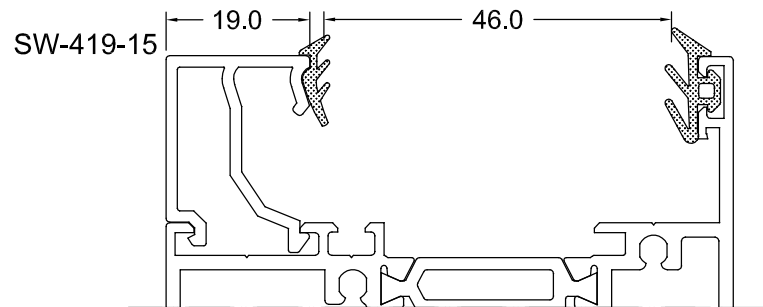
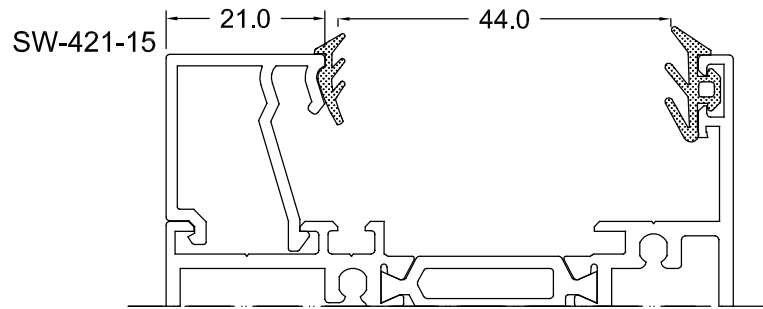
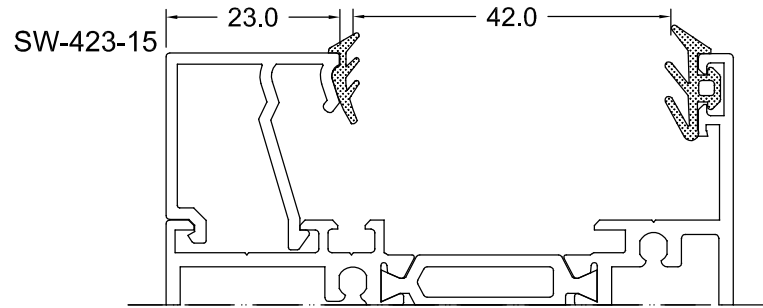
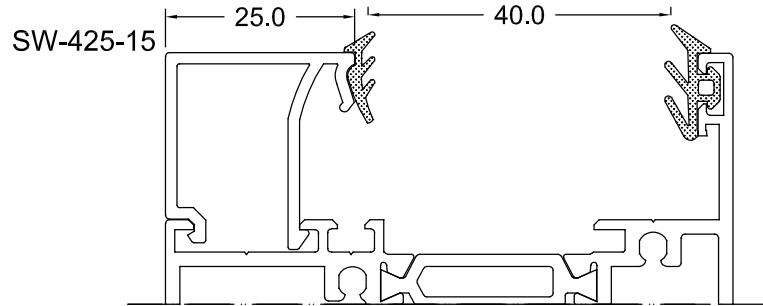



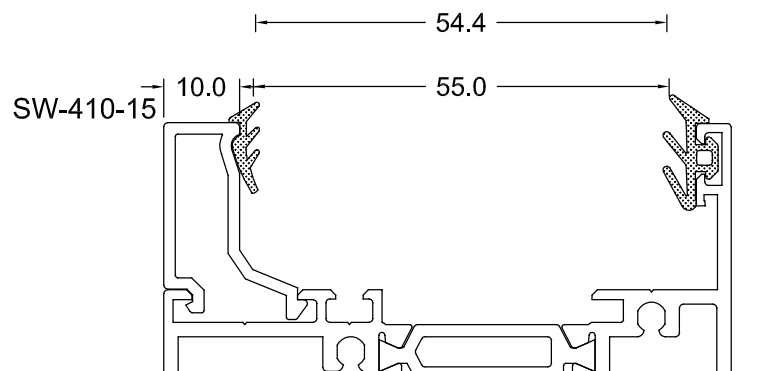
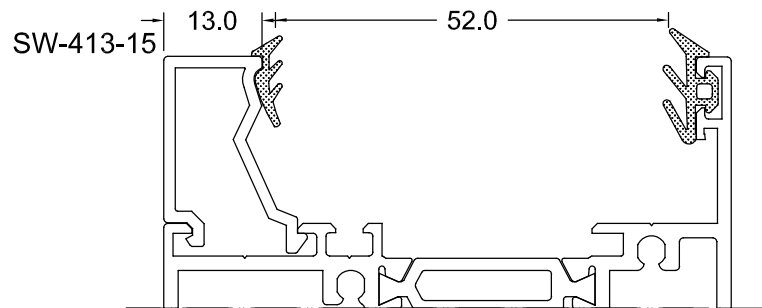
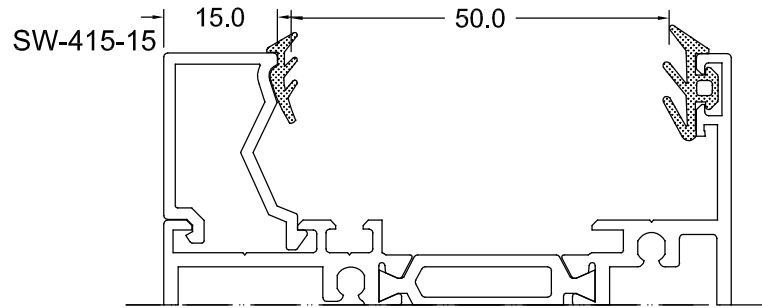
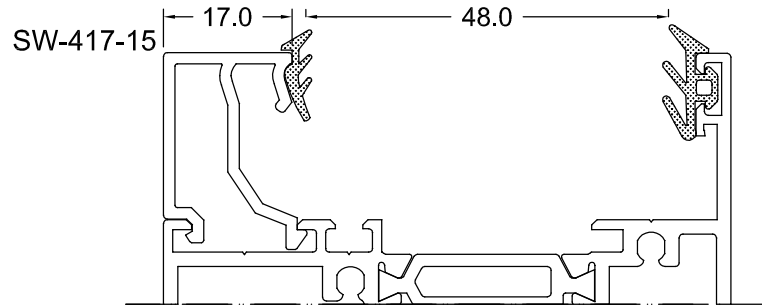



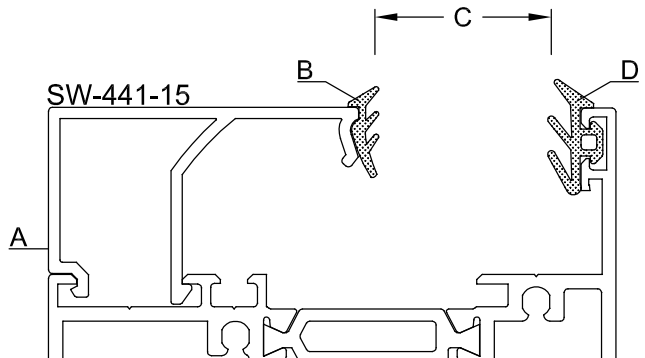
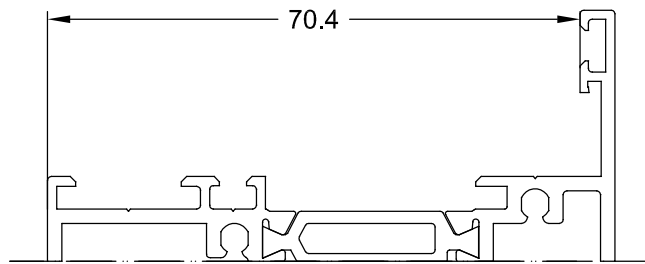

NET CAM BOŞLUKLARI

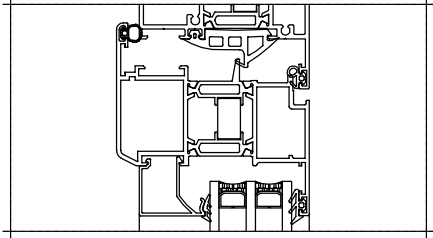

CAM KALINLIĞINA GÖRE FİTİL TAYİNİ

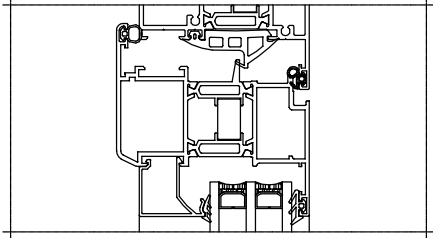
A CAM ÇITASI	B İÇ CAM FİTİLİ	C CAM KALINLIĞI	D DIŞ CAM FİTİLİ	TOPLAM BOŞLUK
SW-441-12	EPD 05	24 mm	EPD 04	70.4 mm
SW-439-12	EPD 05	26 mm	EPD 04	
SW-437-12	EPD 05	28 mm	EPD 04	
SW-435-12	EPD 05	30 mm	EPD 04	
SW-433-12	EPD 05	32 mm	EPD 04	
SW-431-12	EPD 05	34 mm	EPD 04	
SW-429-12	EPD 05	36 mm	EPD 04	
SW-427-12	EPD 05	38 mm	EPD 04	
SW-425-12	EPD 05	40 mm	EPD 04	
SW-423-12	EPD 05	42 mm	EPD 04	
SW-421-12	EPD 05	44 mm	EPD 04	
SW-419-12	EPD 05	46 mm	EPD 04	
SW-417-12	EPD 05	48 mm	EPD 04	
SW-415-12	EPD 05	50 mm	EPD 04	
SW-413-12	EPD 05	52 mm	EPD 04	
SW-410-12	EPD 05	55 mm	EPD 04	
SW-405-14	EPD 05	60 mm	EPD 04	

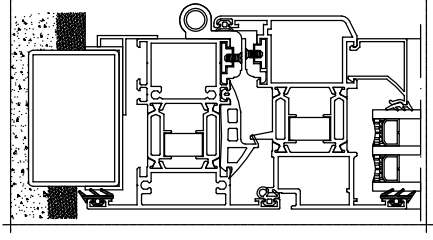

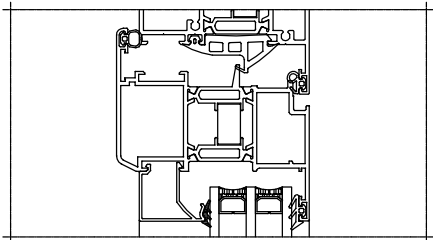
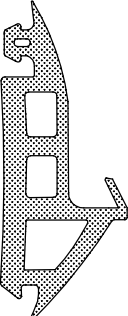
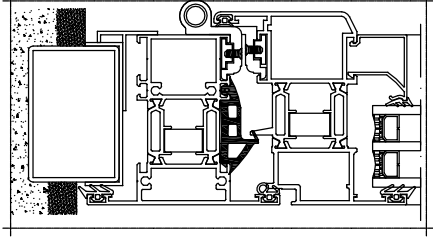
Fitul Kodu	Fitul Resmi	Teslimat Şekli	Montaj Çizimi
<u>EPD 01</u>		1 KOLİ 380mt/13Kg 34gr/m	
<u>EPD 02</u>		1 KOLİ 350mt/15Kg 42gr/m	
<u>EPD 04</u>		1 KOLİ 270mt/16Kg 59gr/m	
<u>EPD 05</u>		1 KOLİ 340mt/15Kg 44gr/m	
<u>EPD 08</u>		1 KOLİ 45mt/13Kg 288gr/m	



ALUFOUR

YALITIMLI DOĞRAMA SİSTEMİ

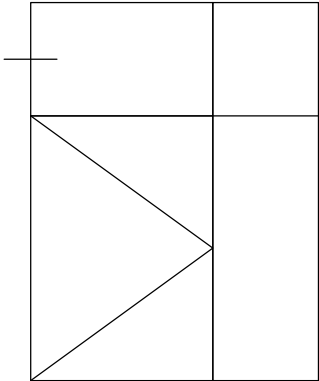

01

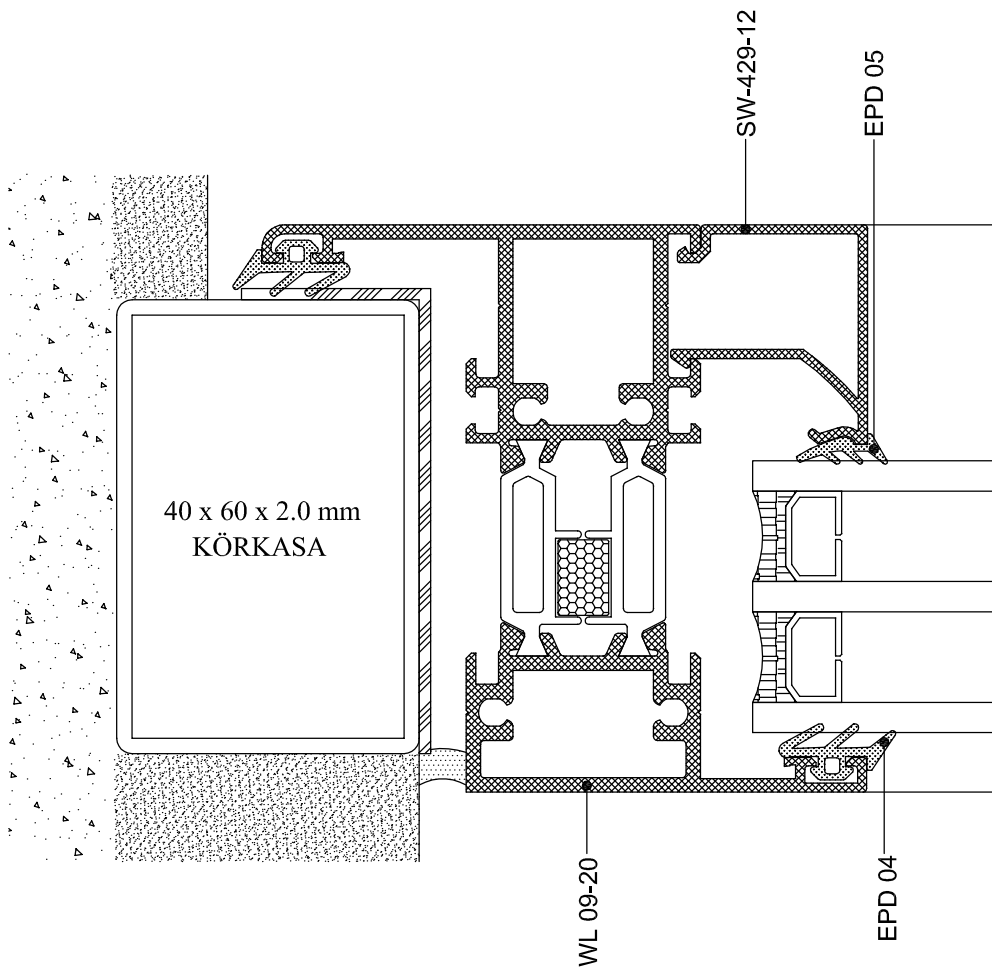

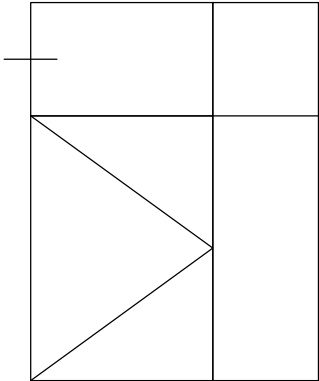

02

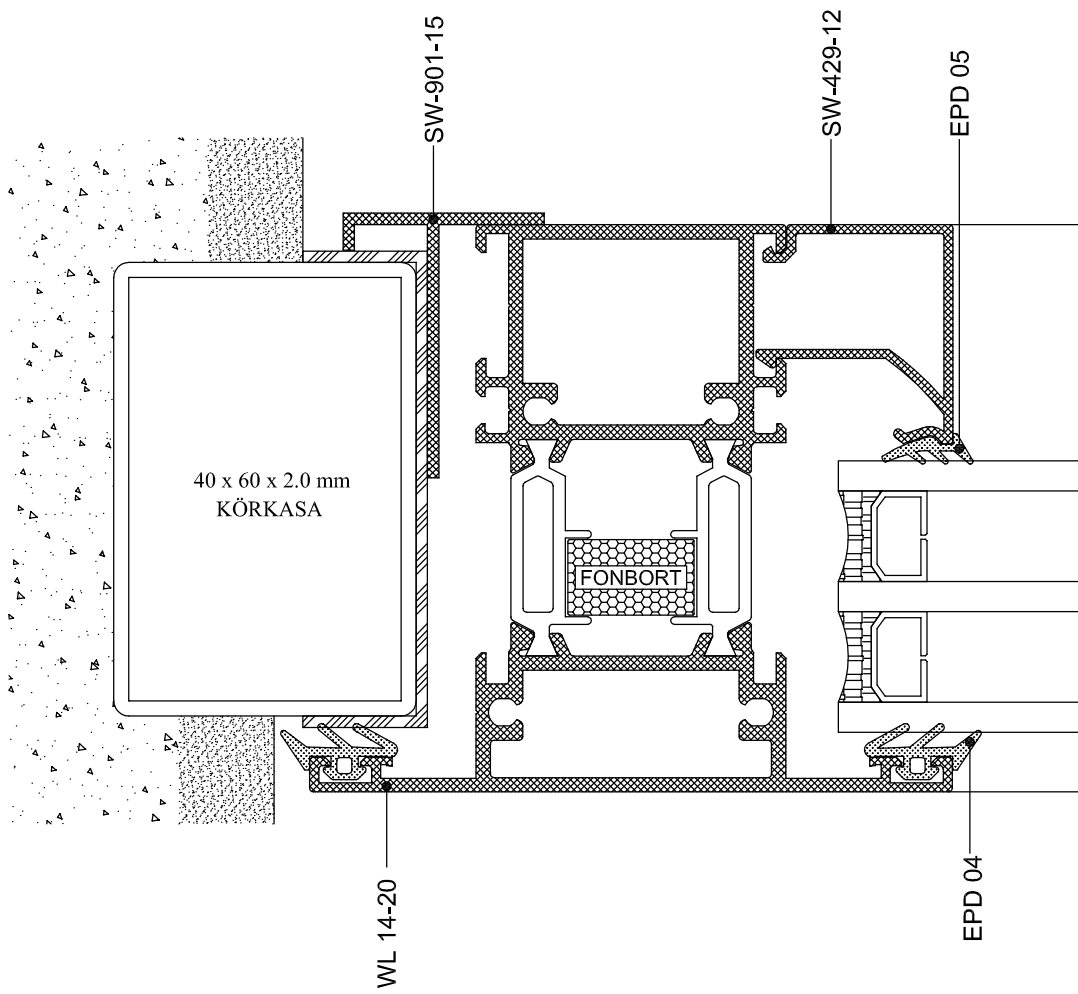

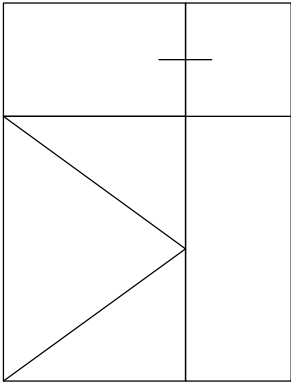

03

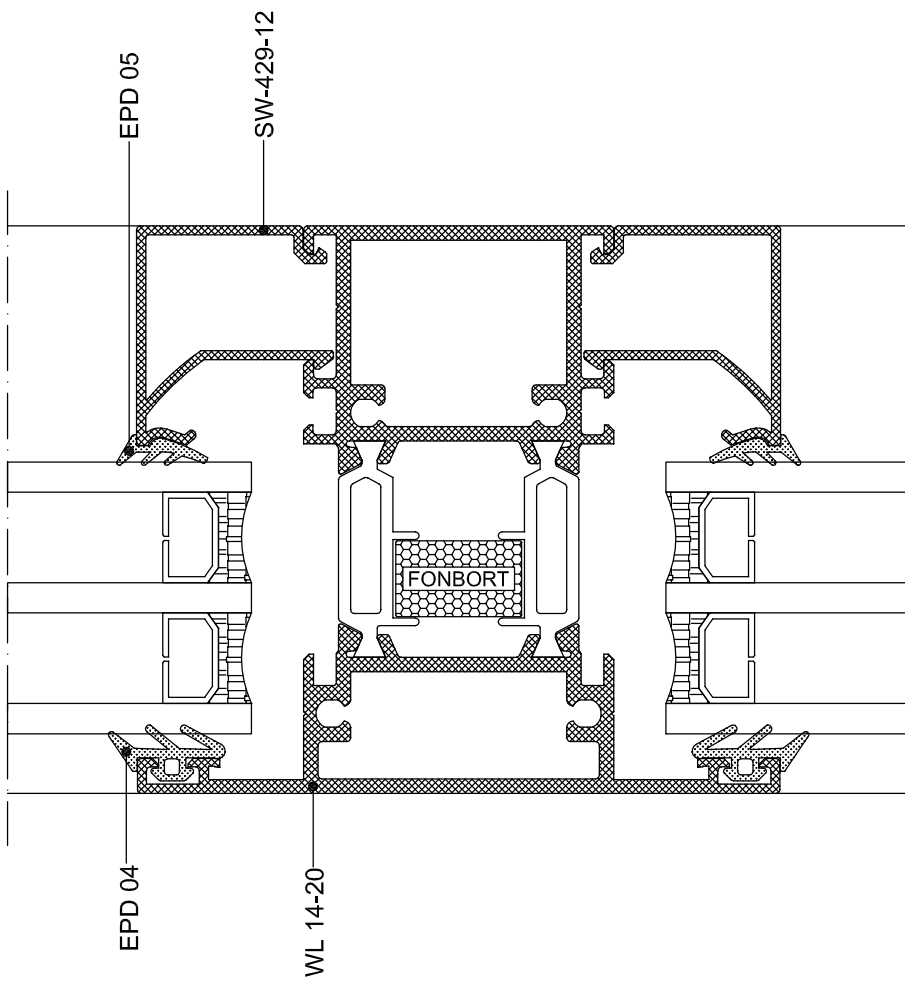

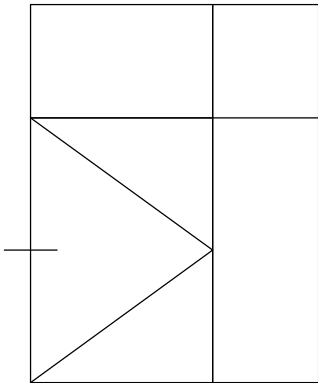

04

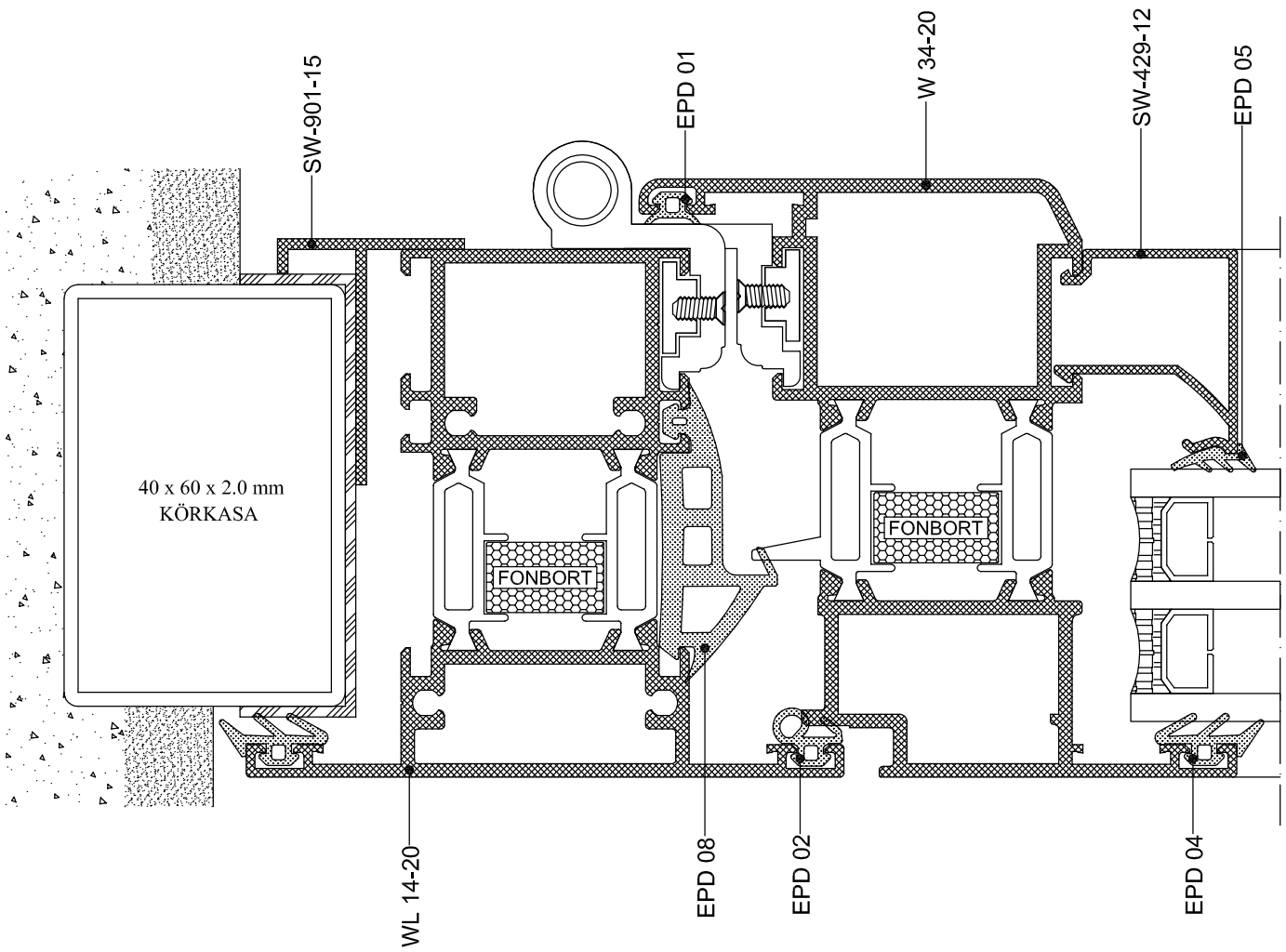

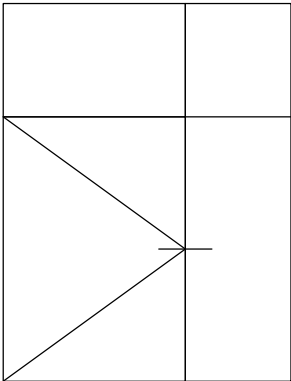

05

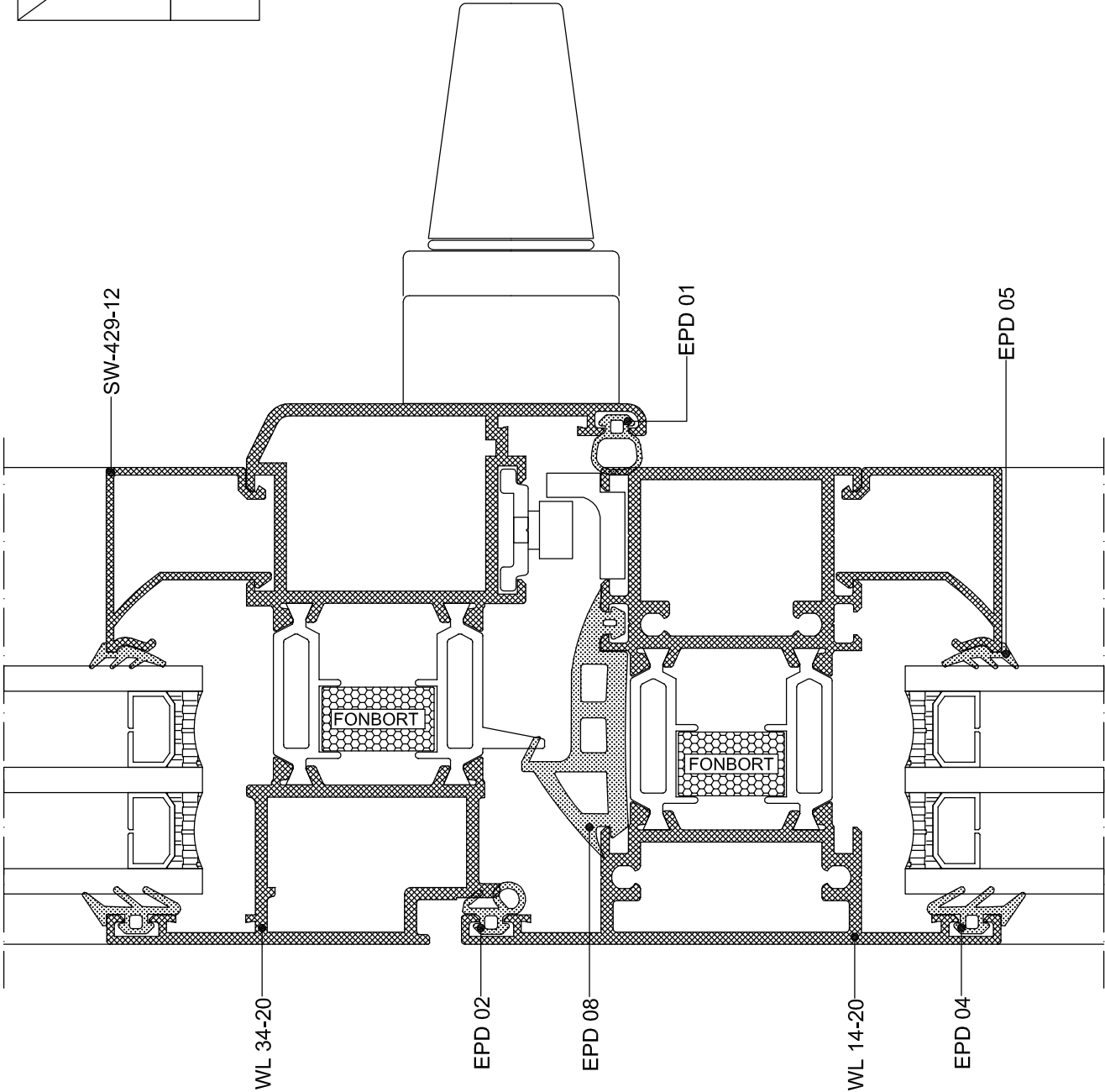

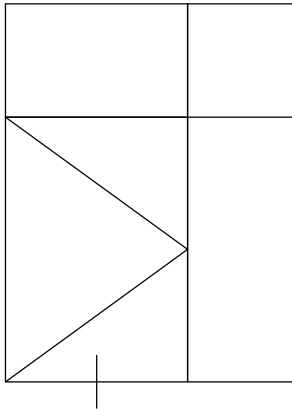

06

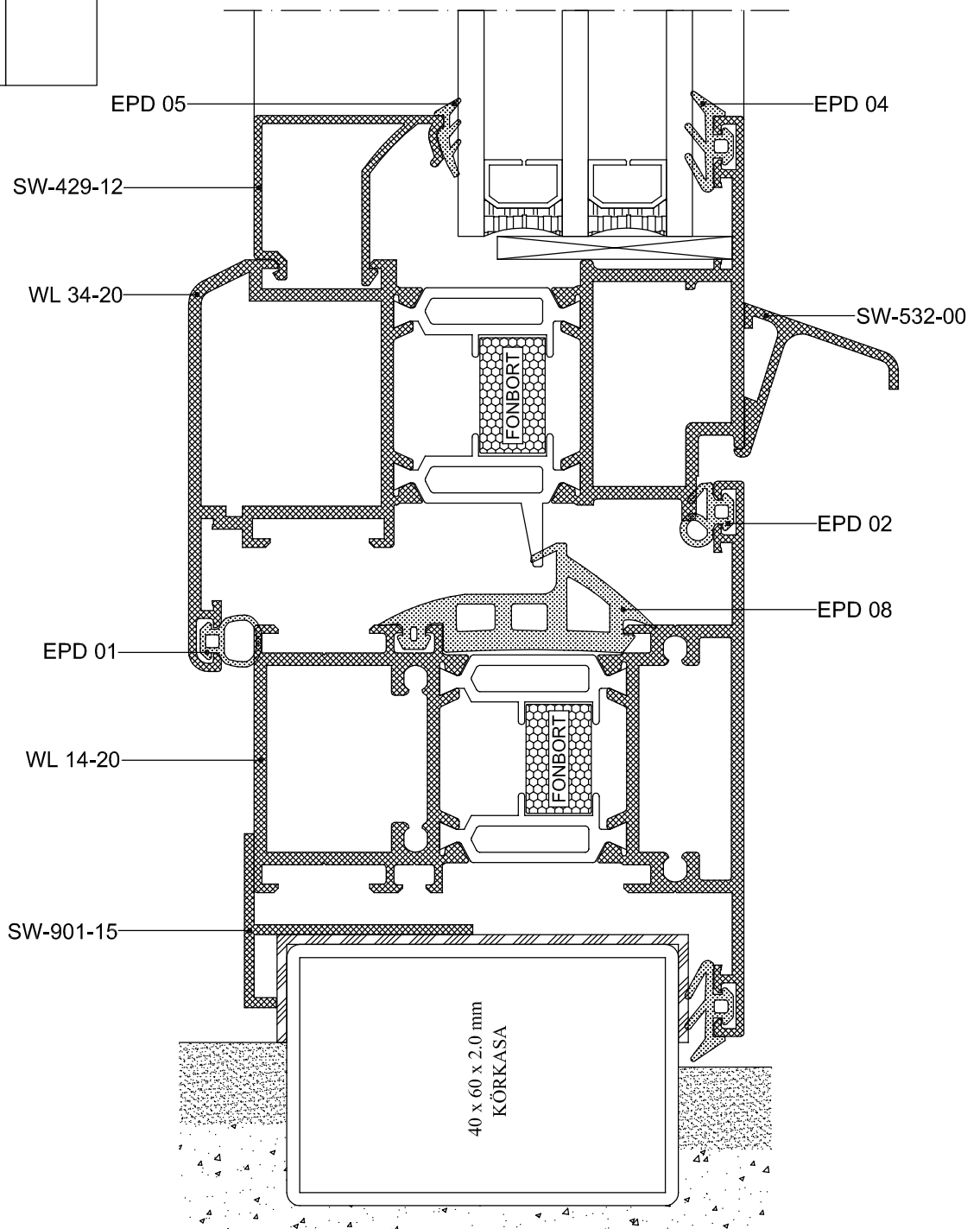

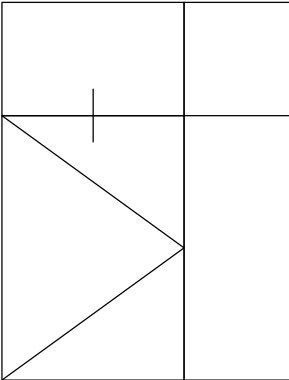

07

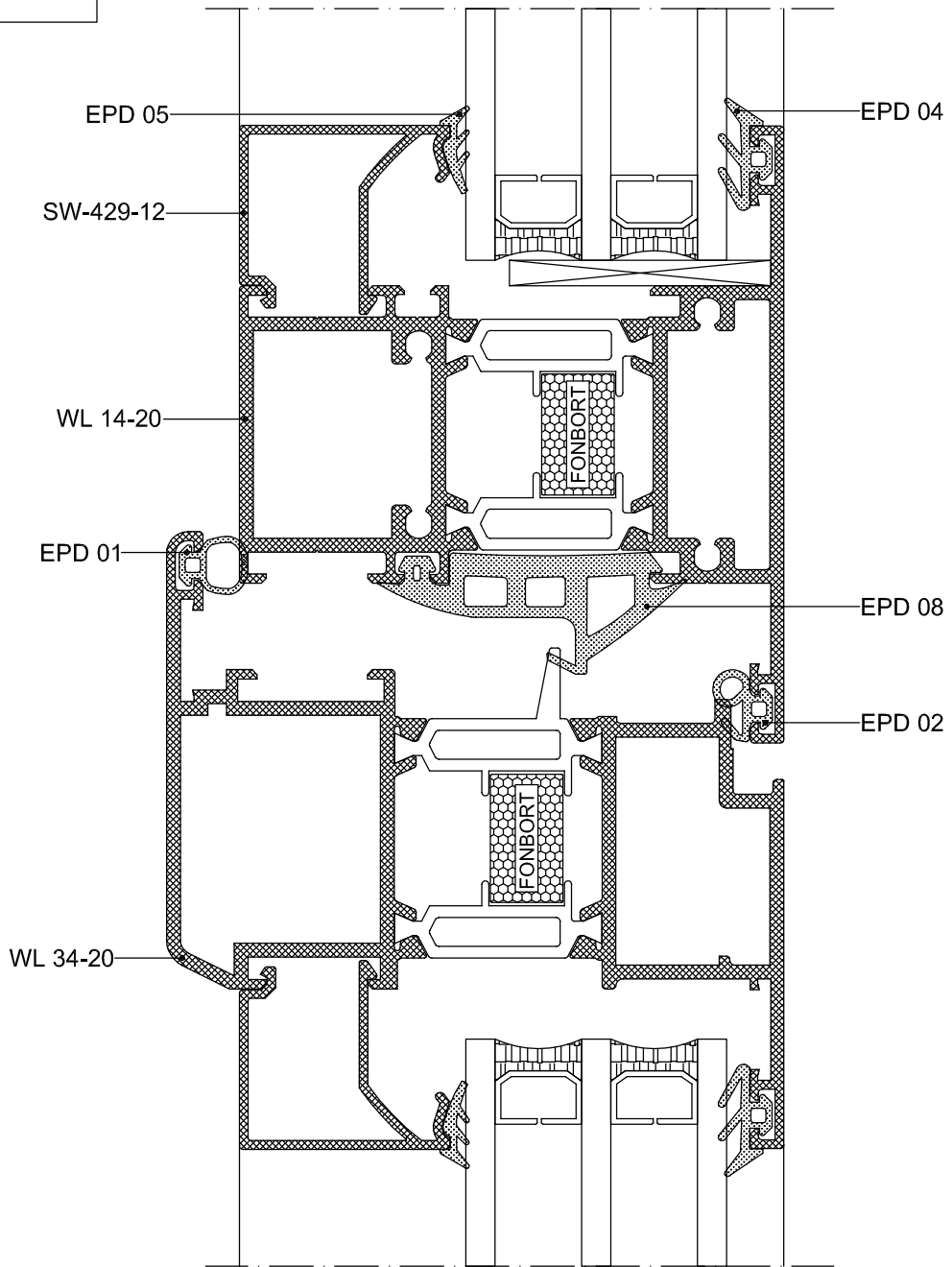

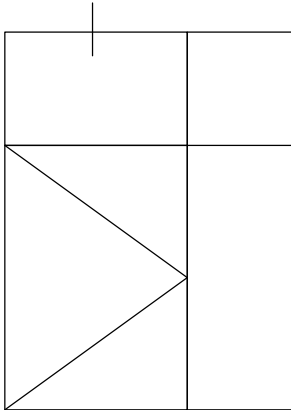

08

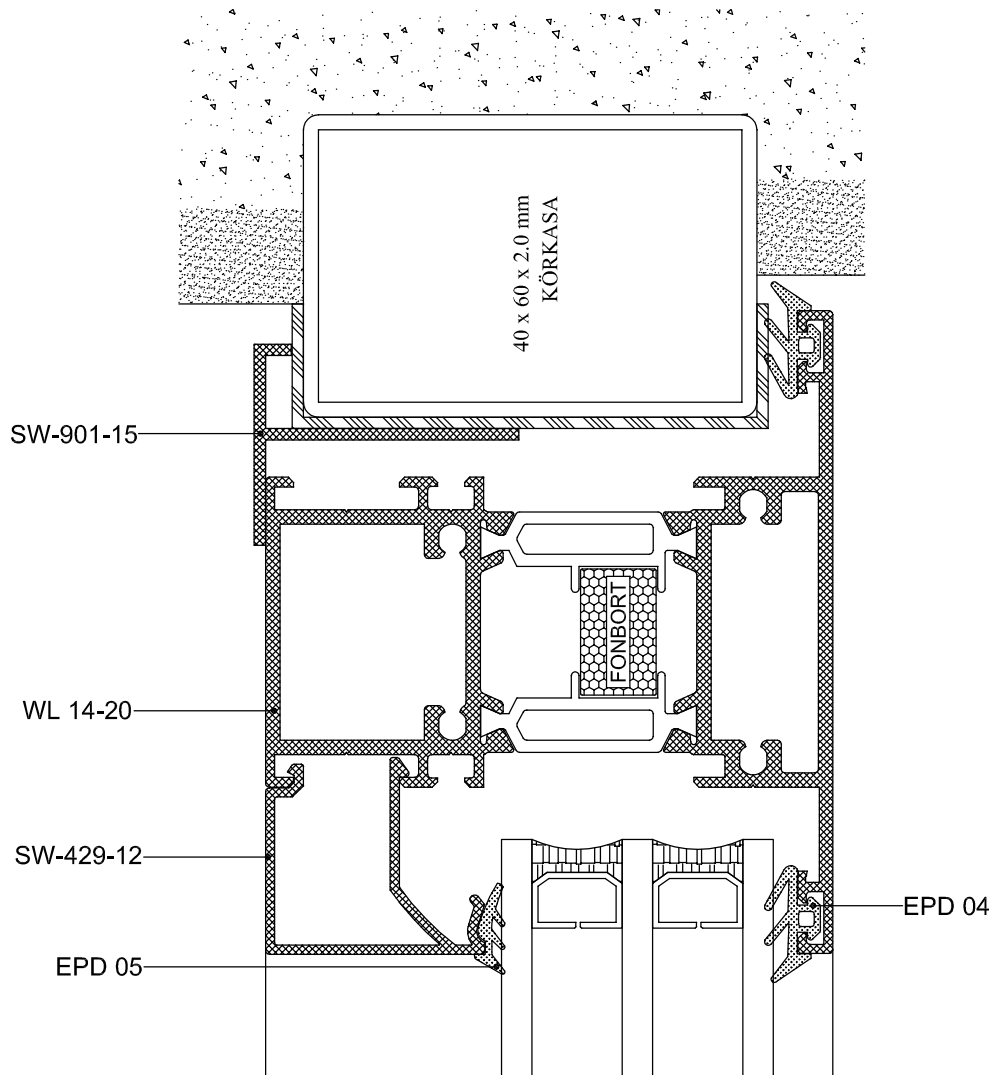

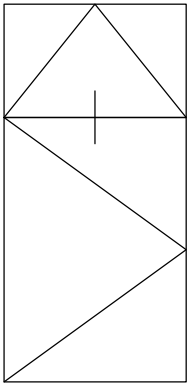

09

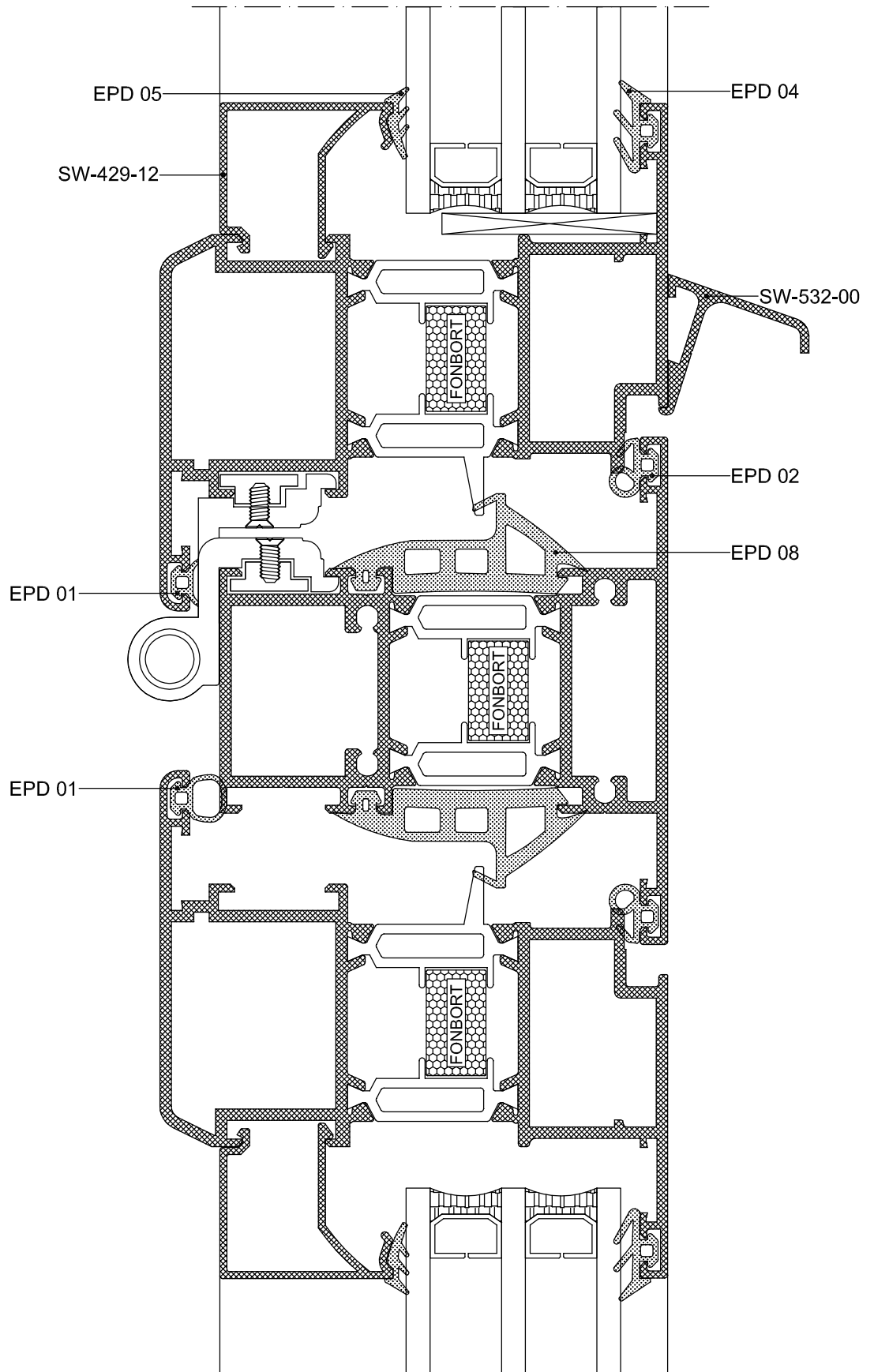

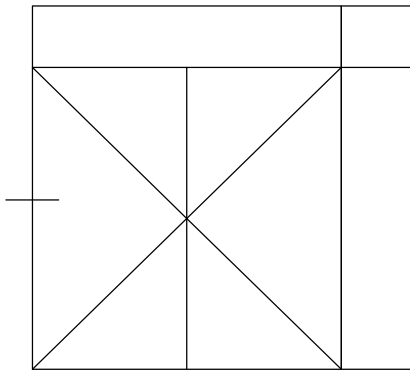

10

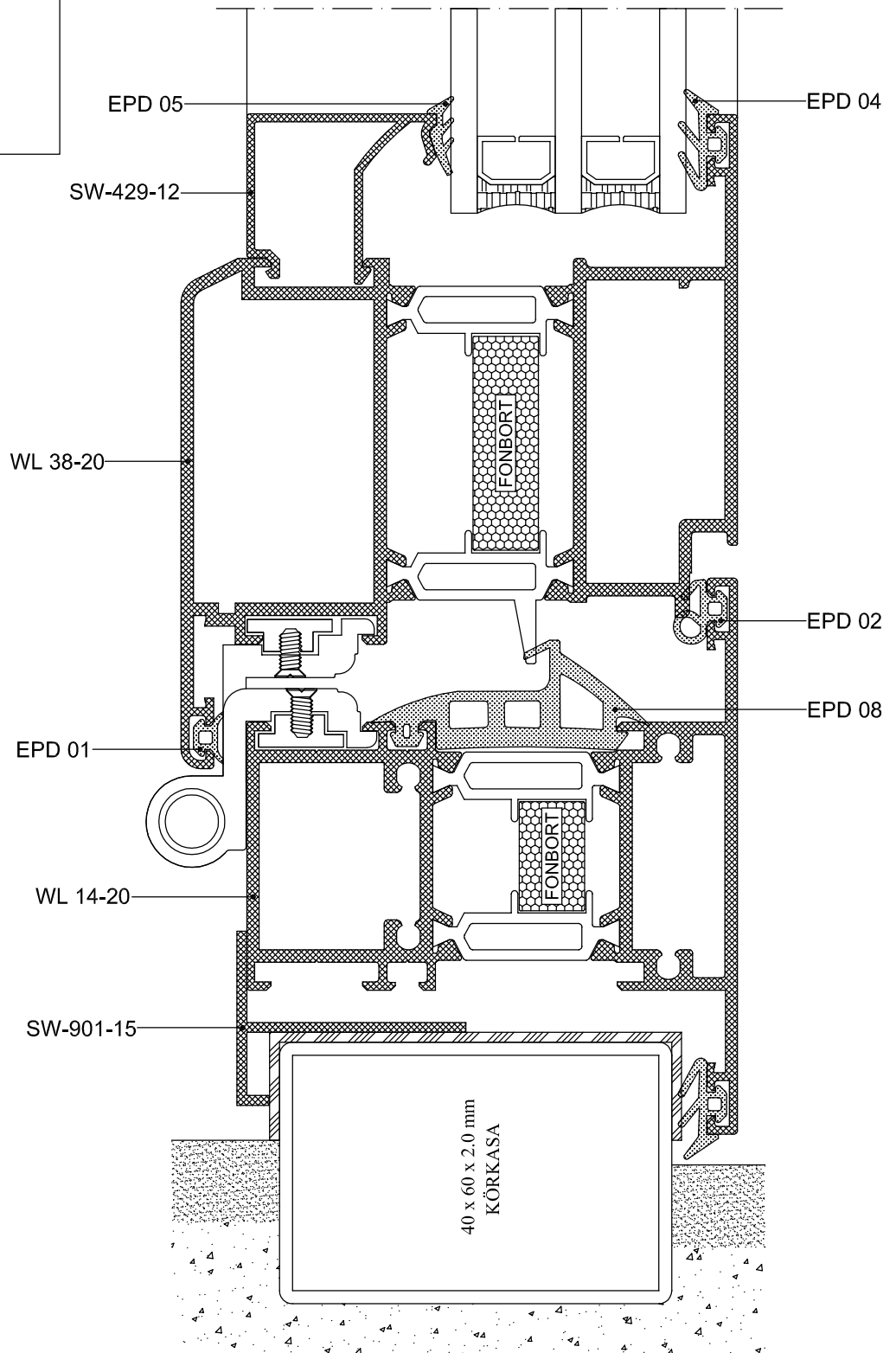

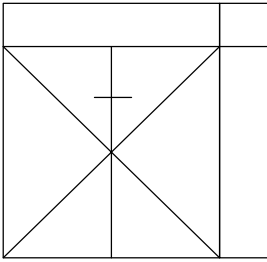

11

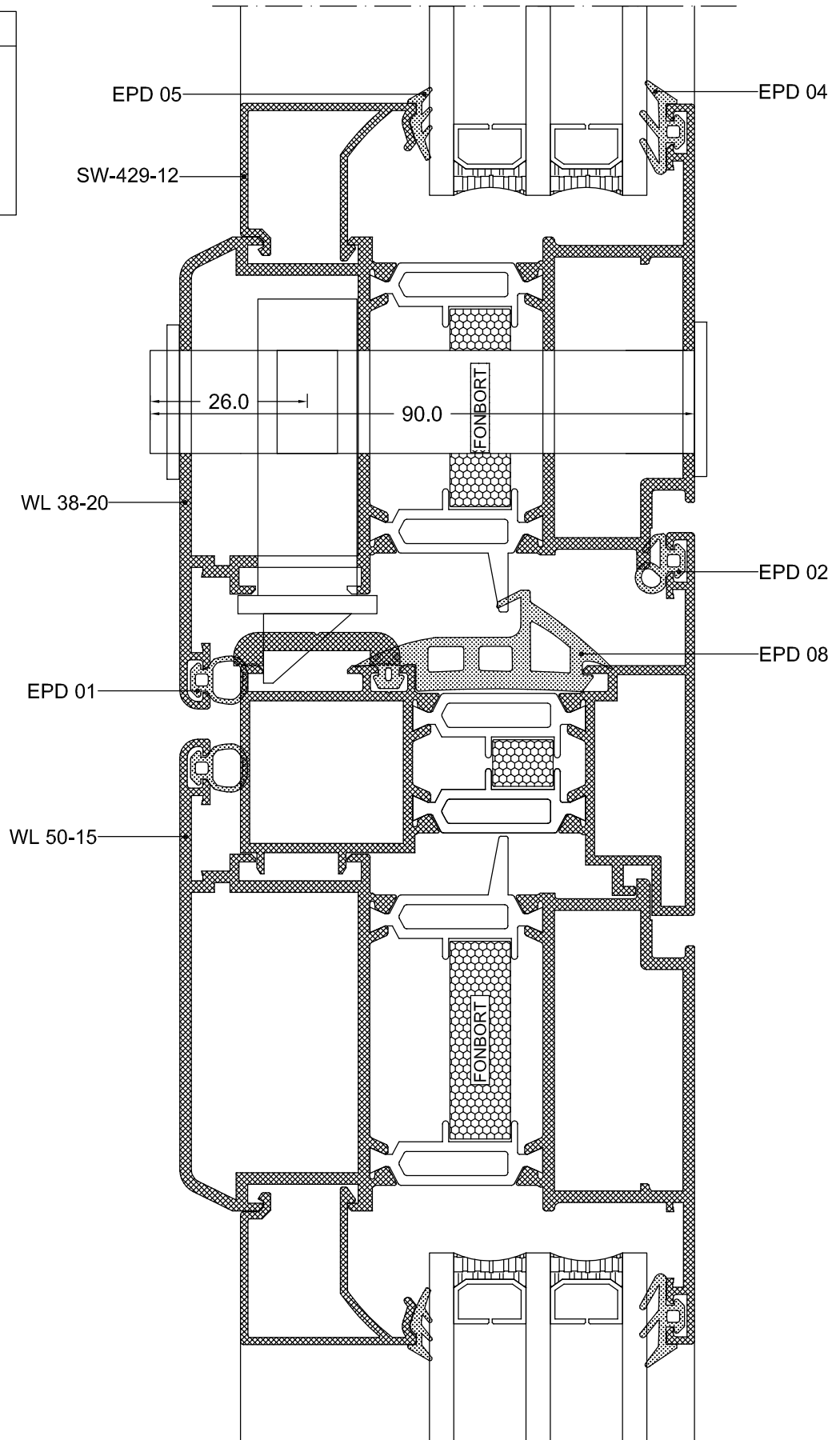

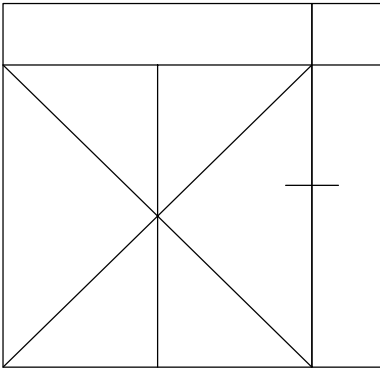

12

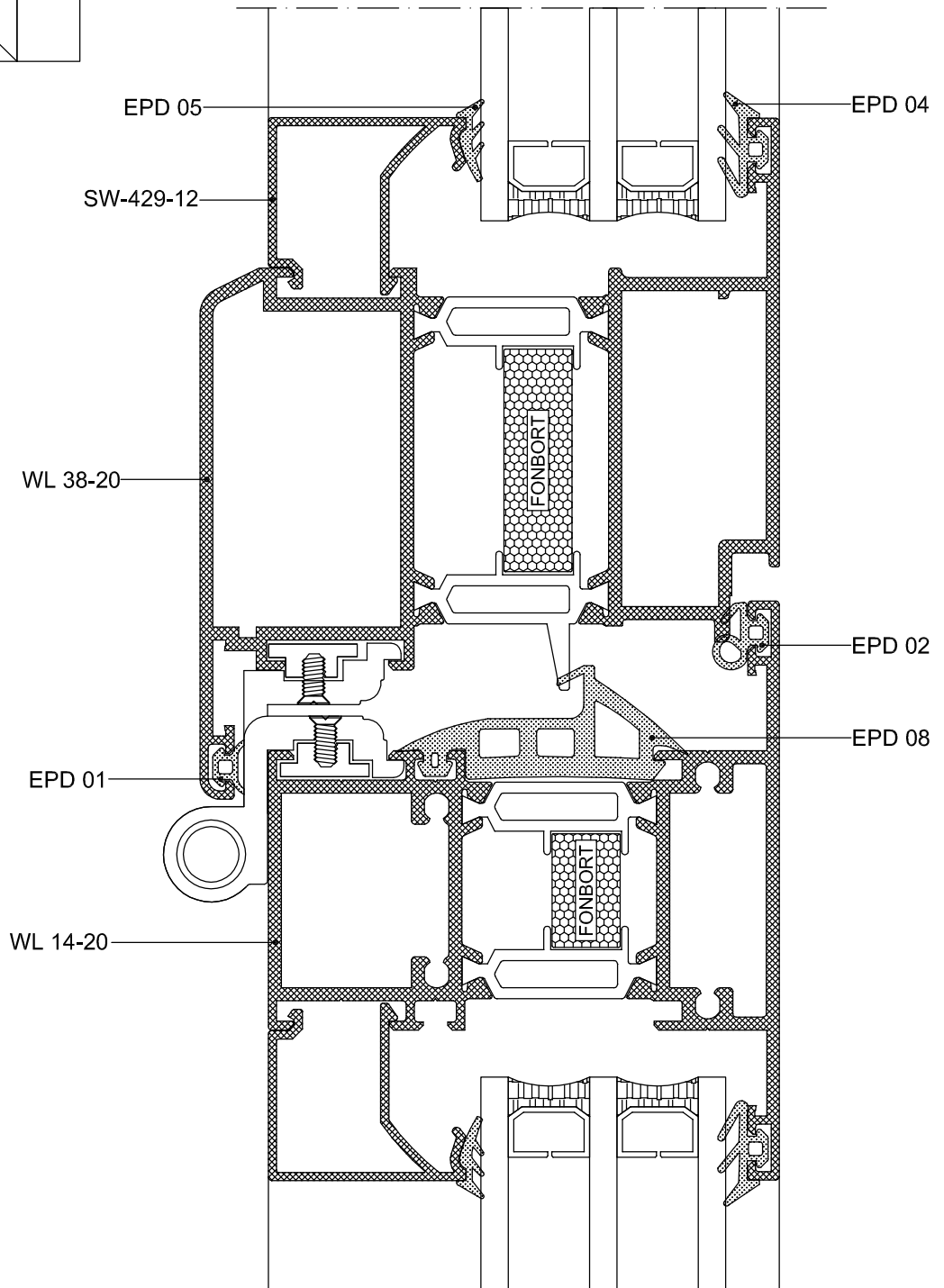

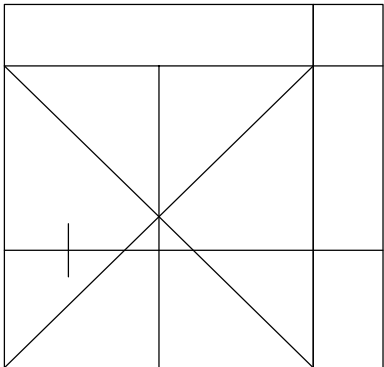

13

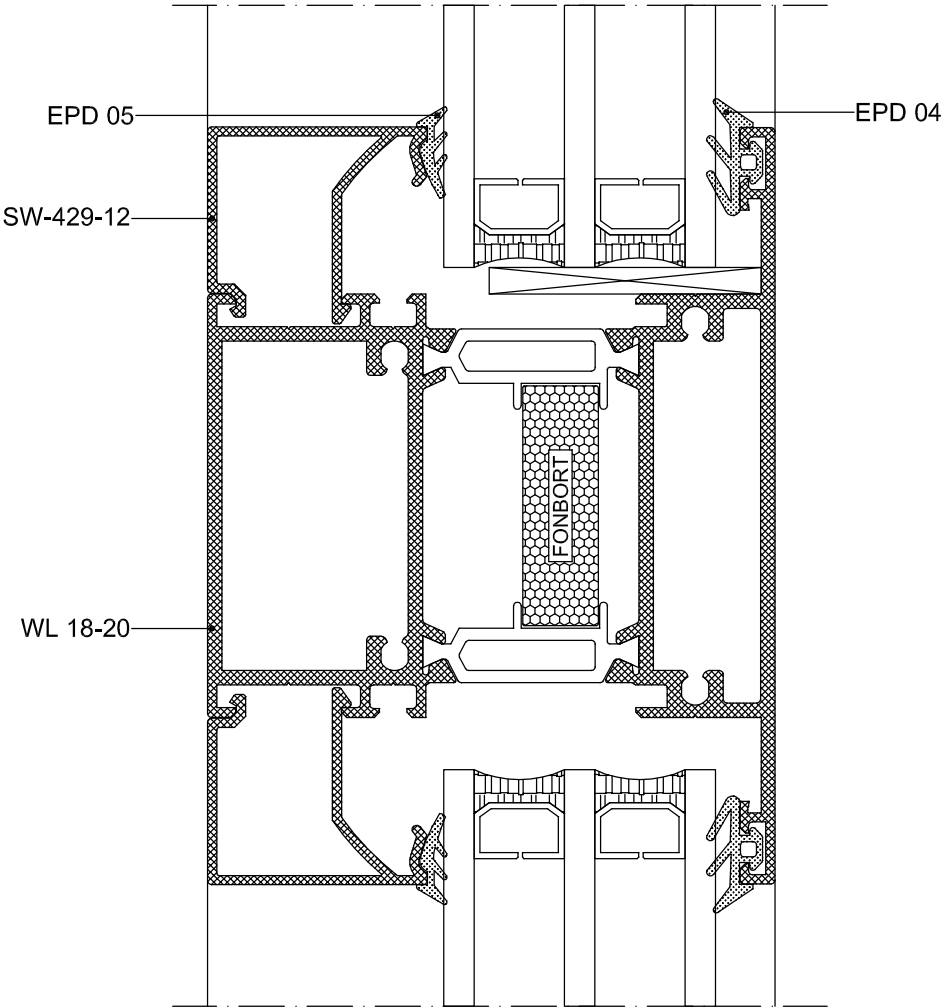

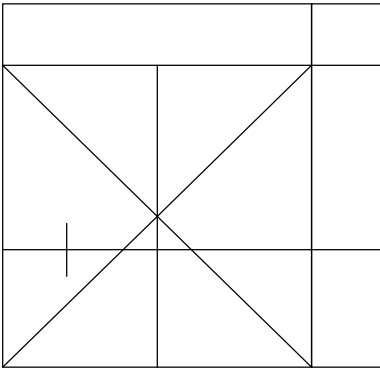

14

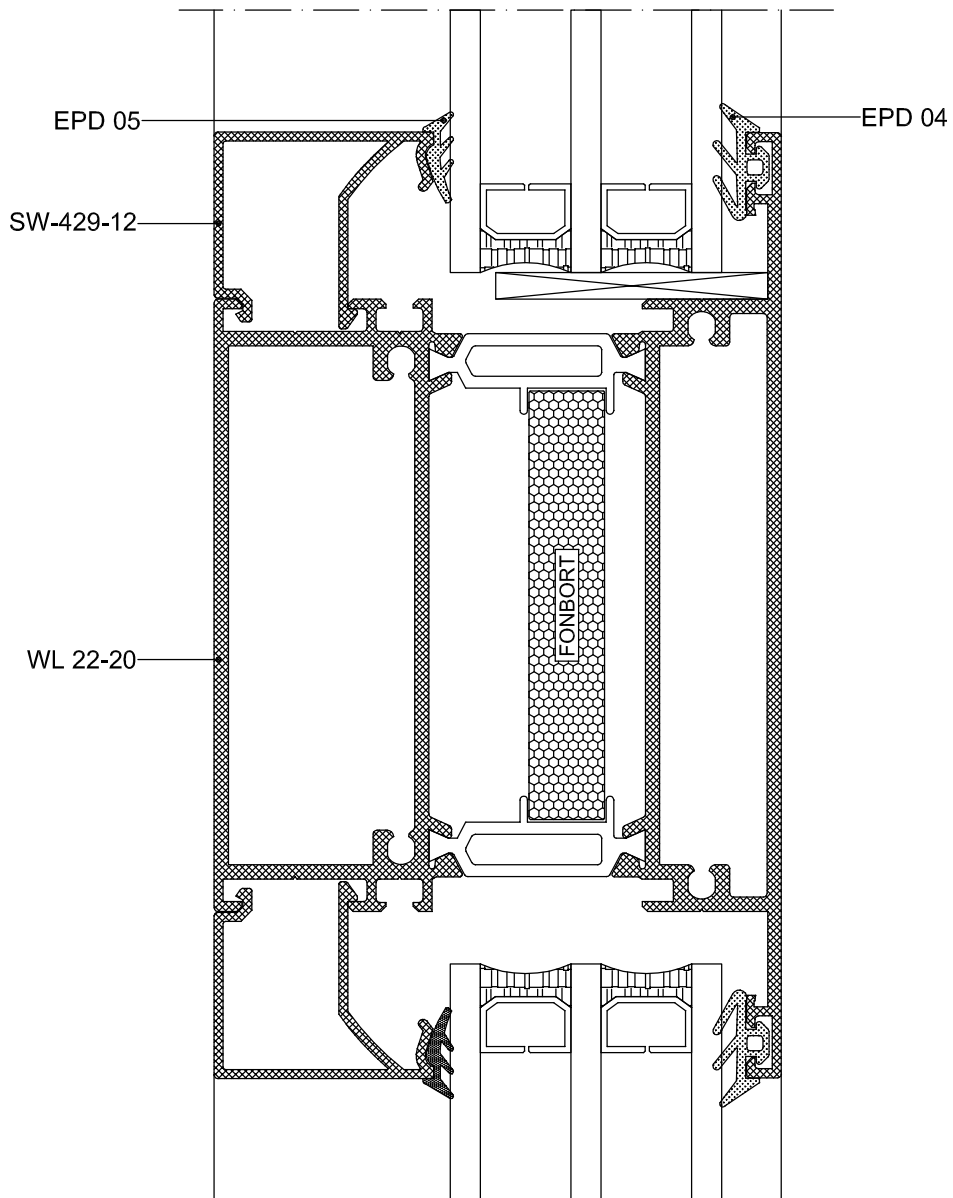

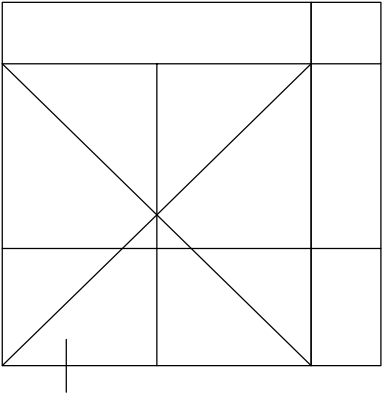

15

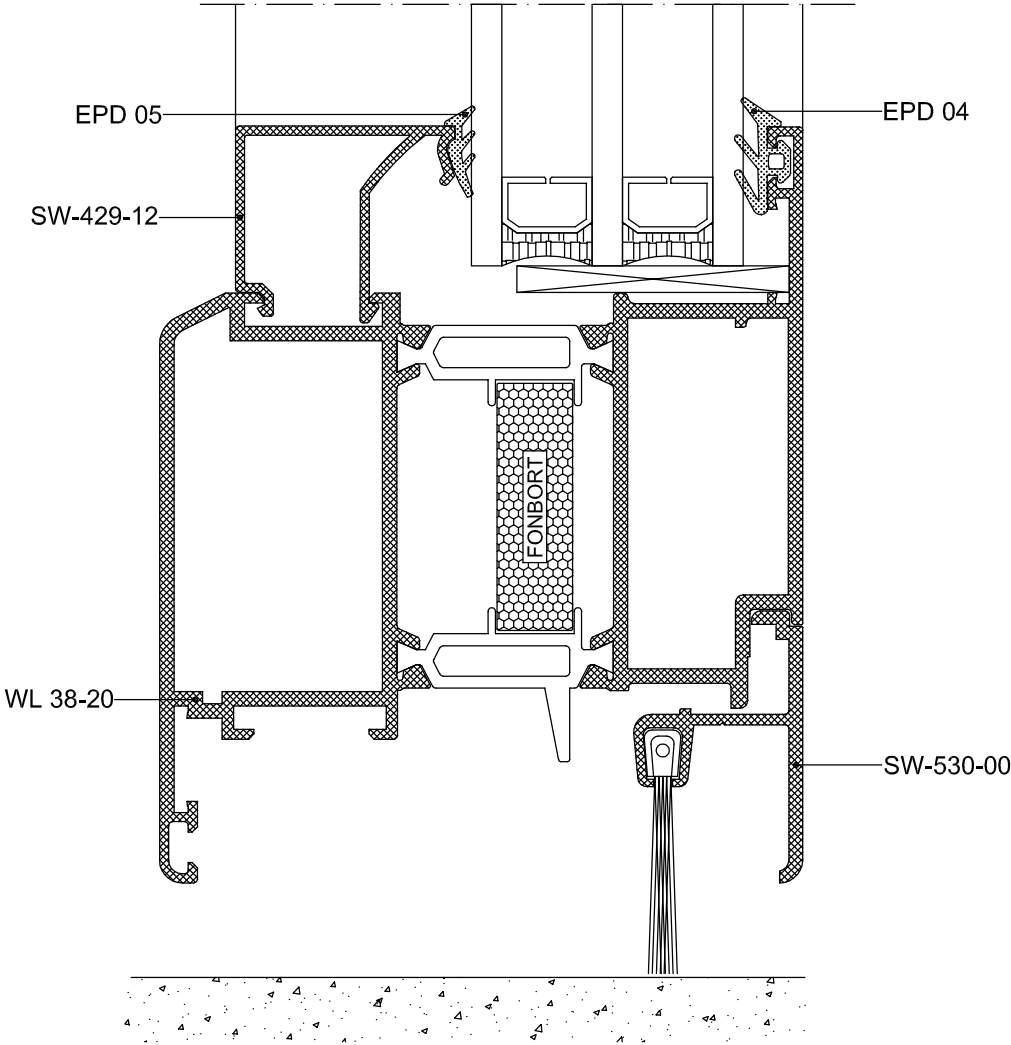

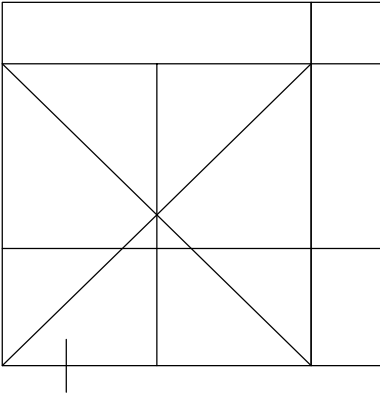

16

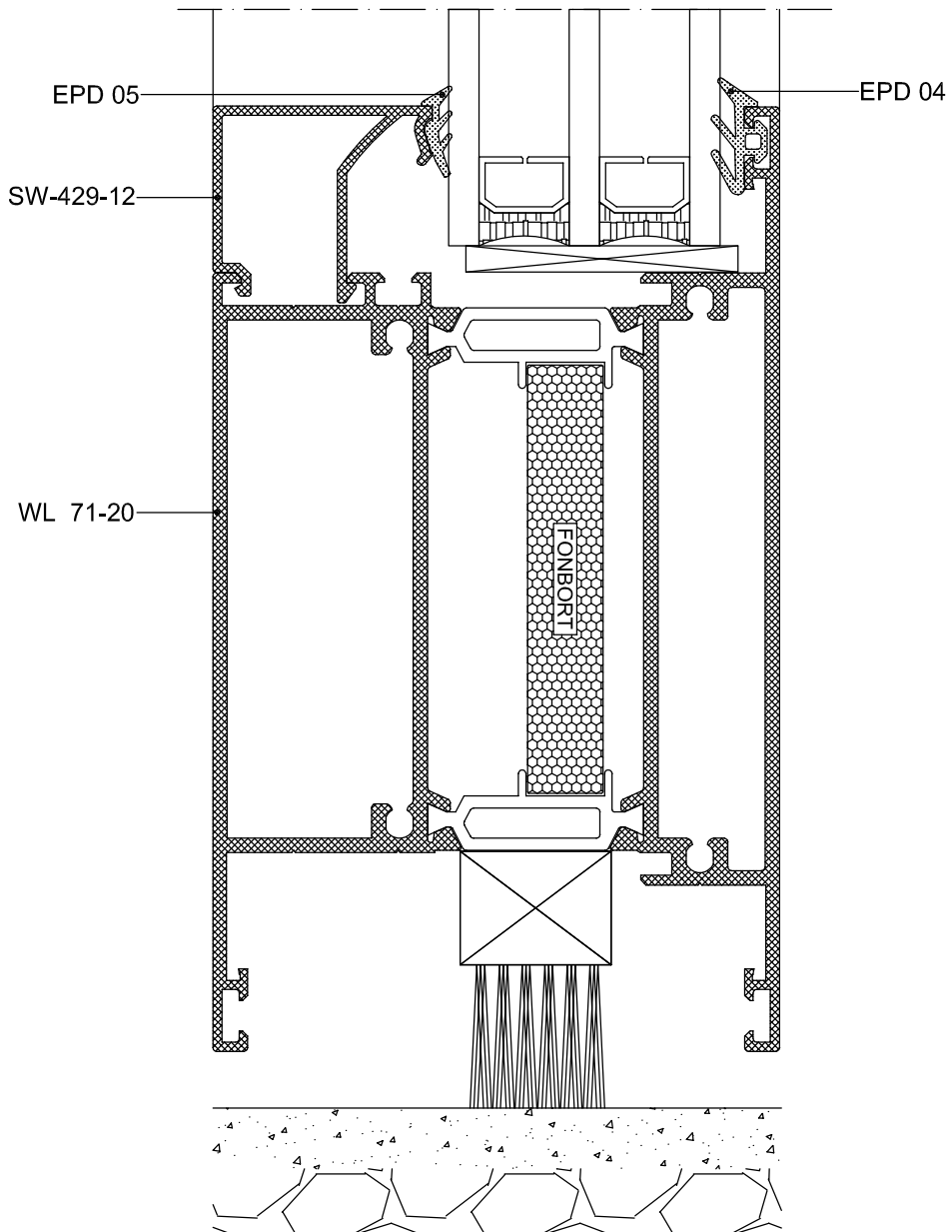

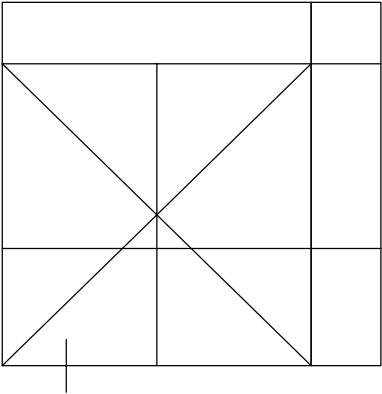

17

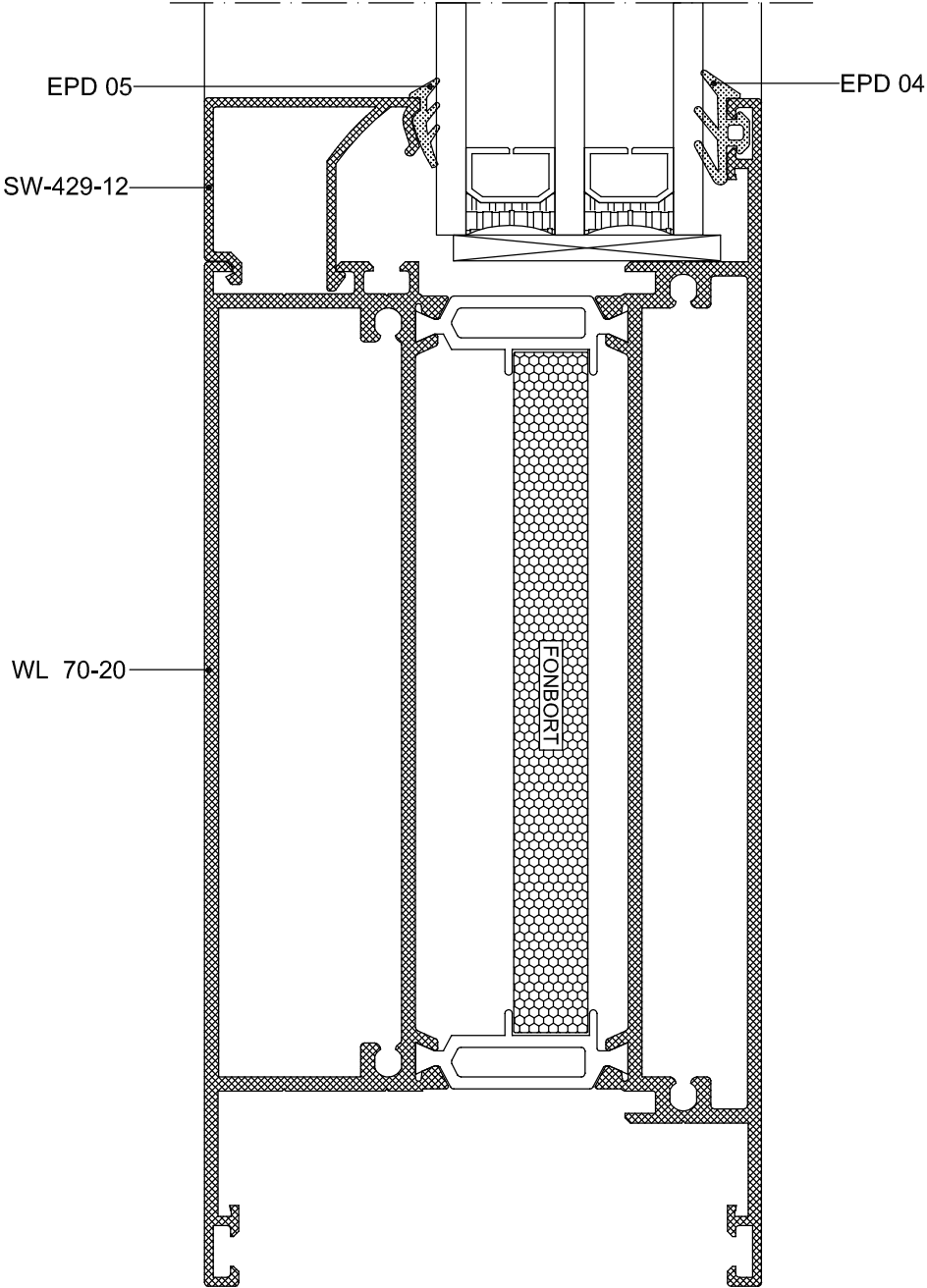

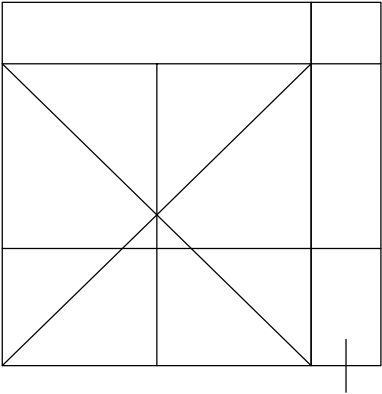

18

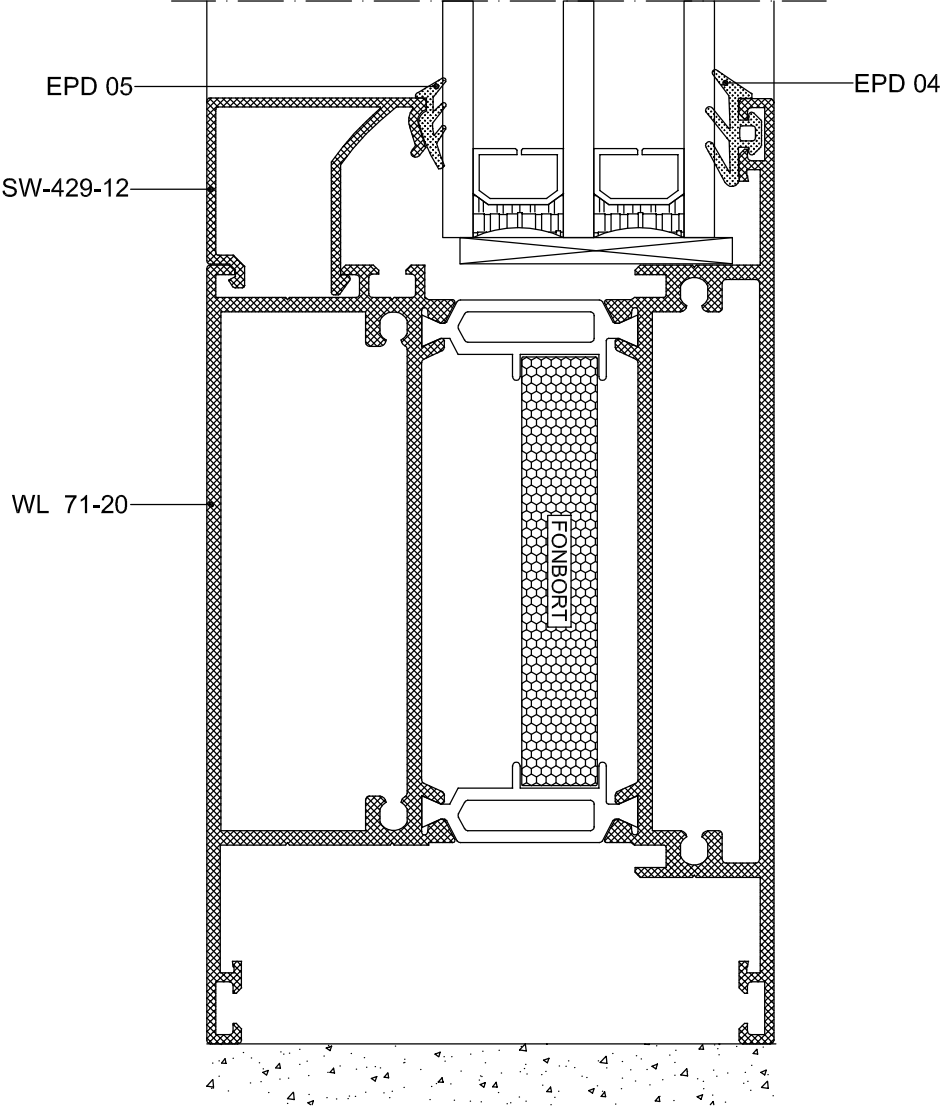

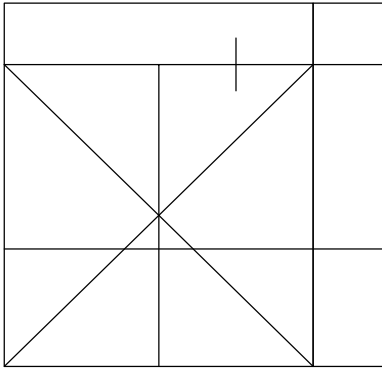

19

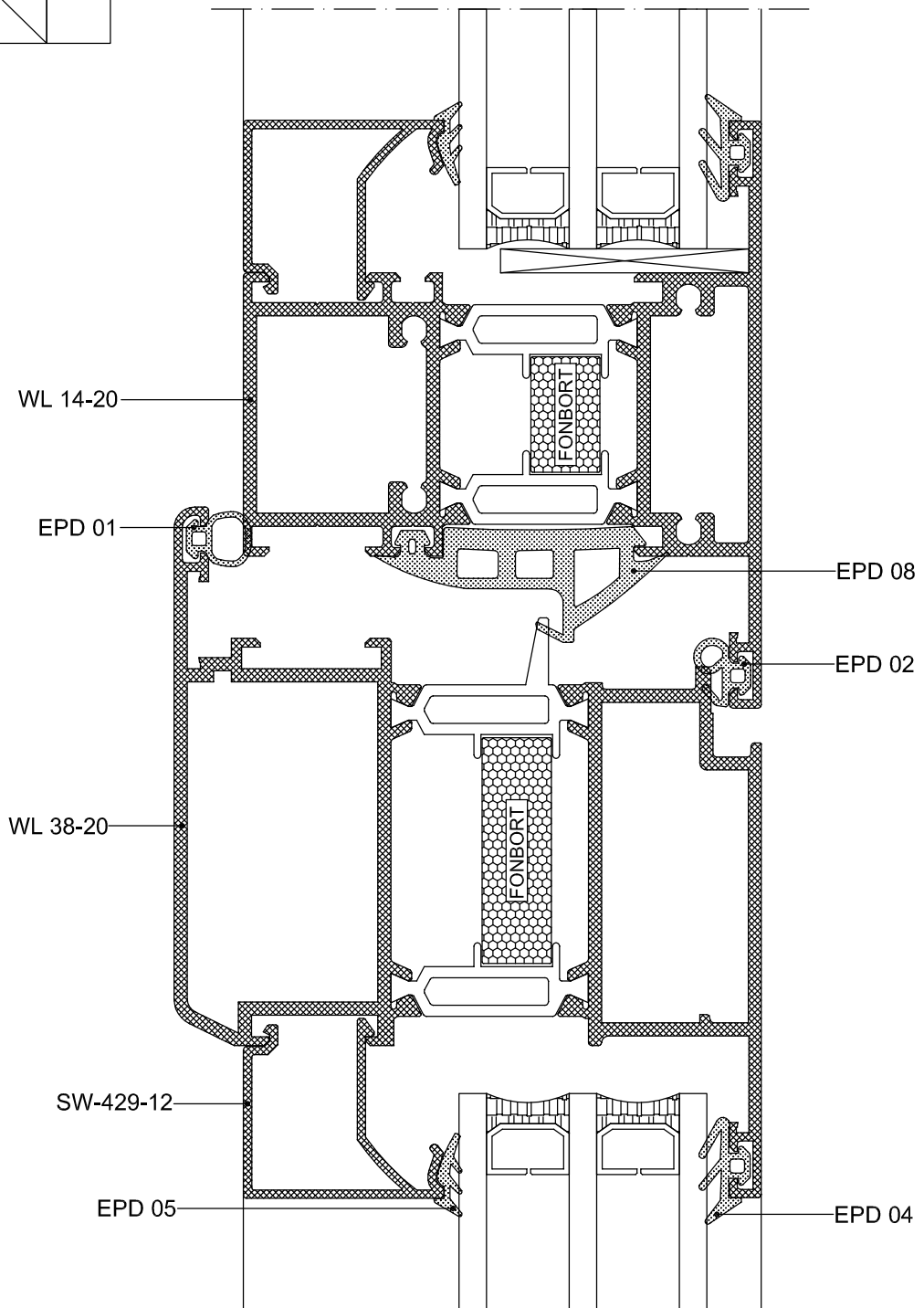

20

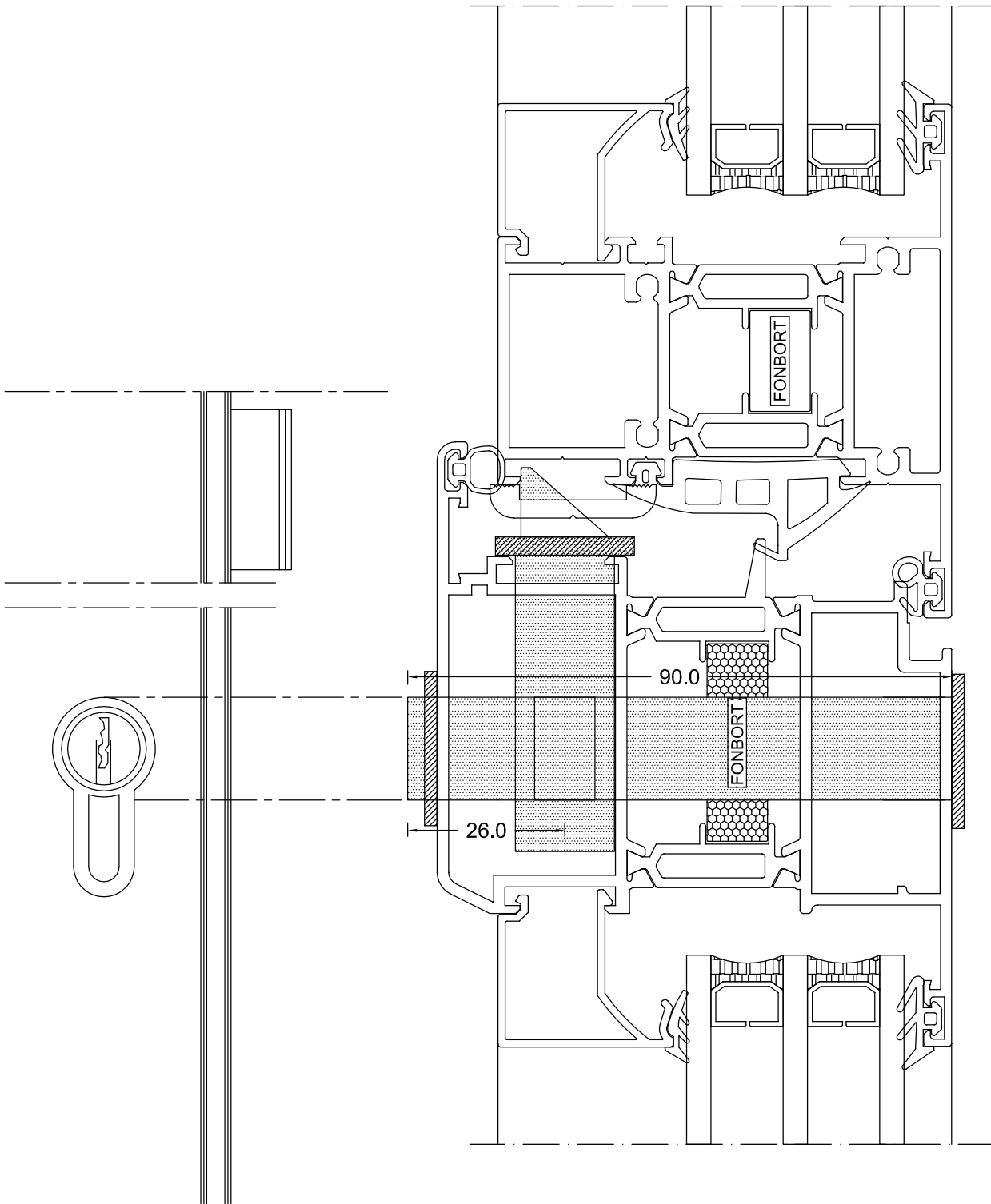

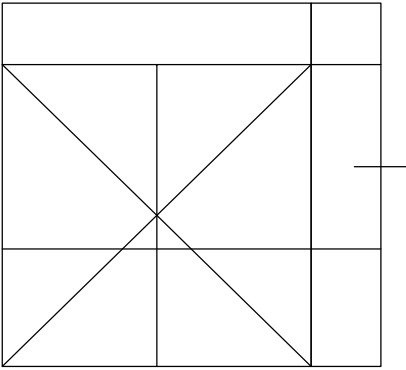

21

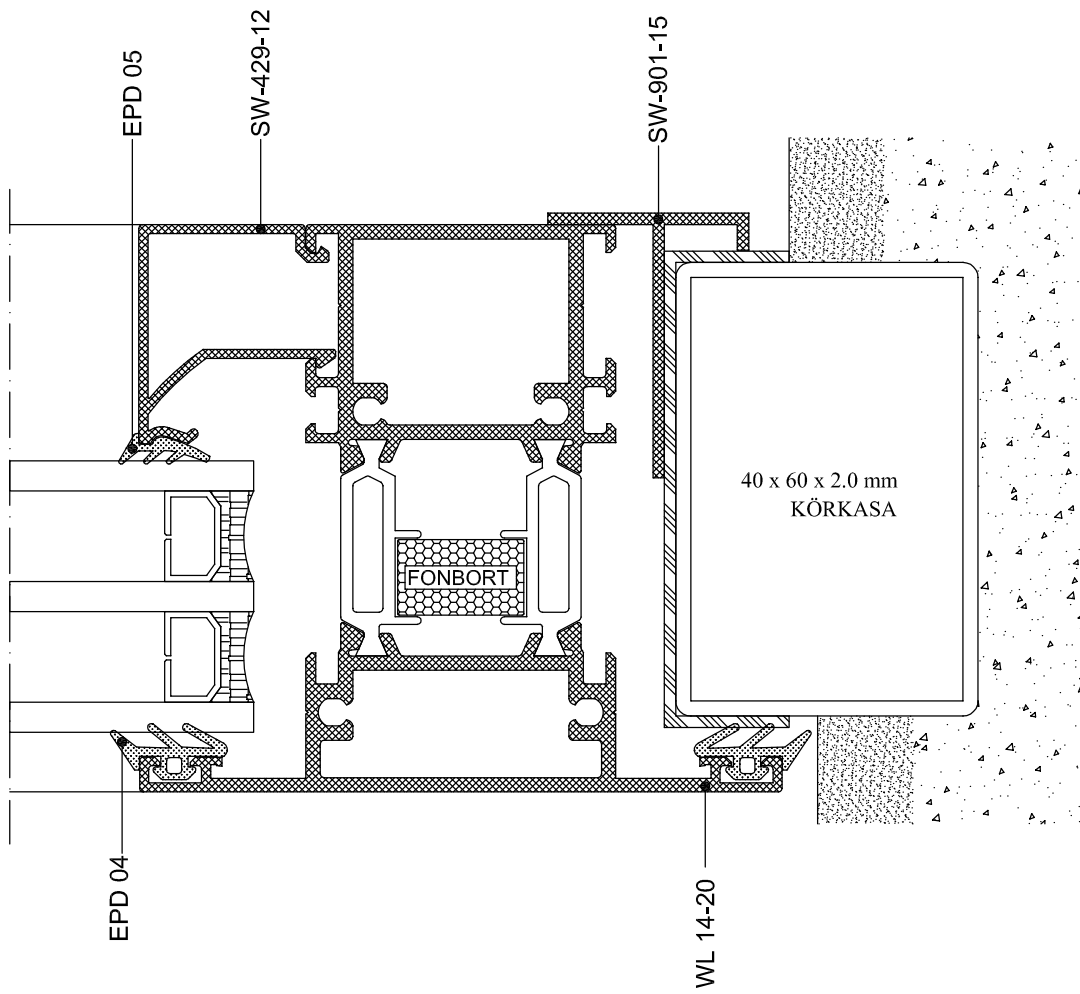

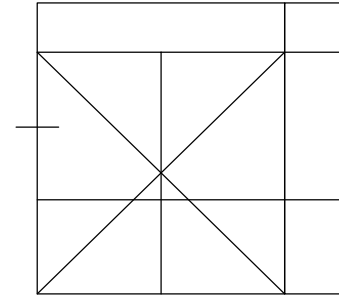

DIŐA AÇILIR KAPI

DIŐA AÇILIR KAPI UYGULAMA DETAYLARI

22

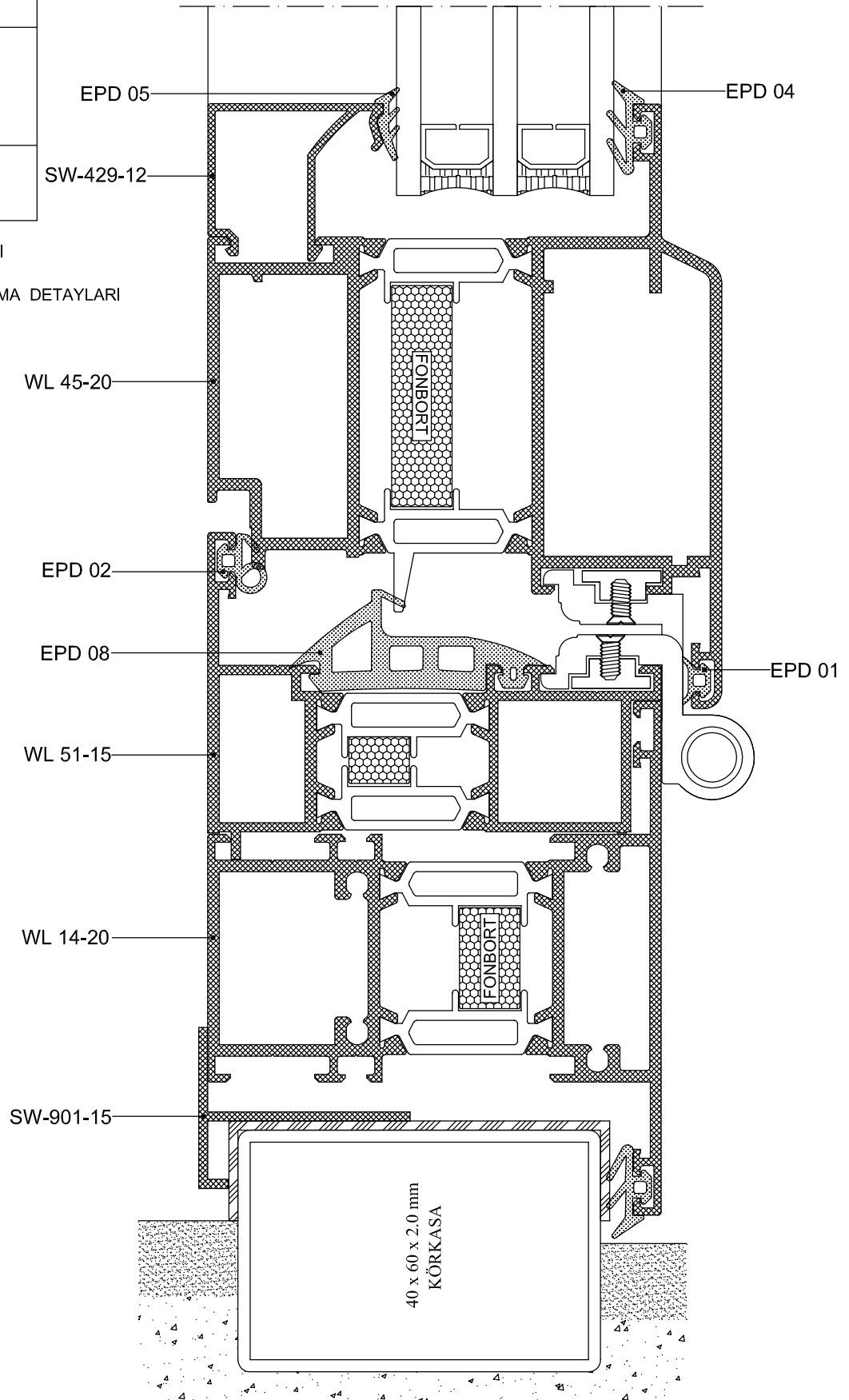

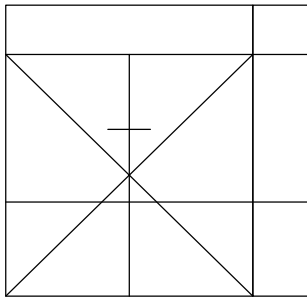

23

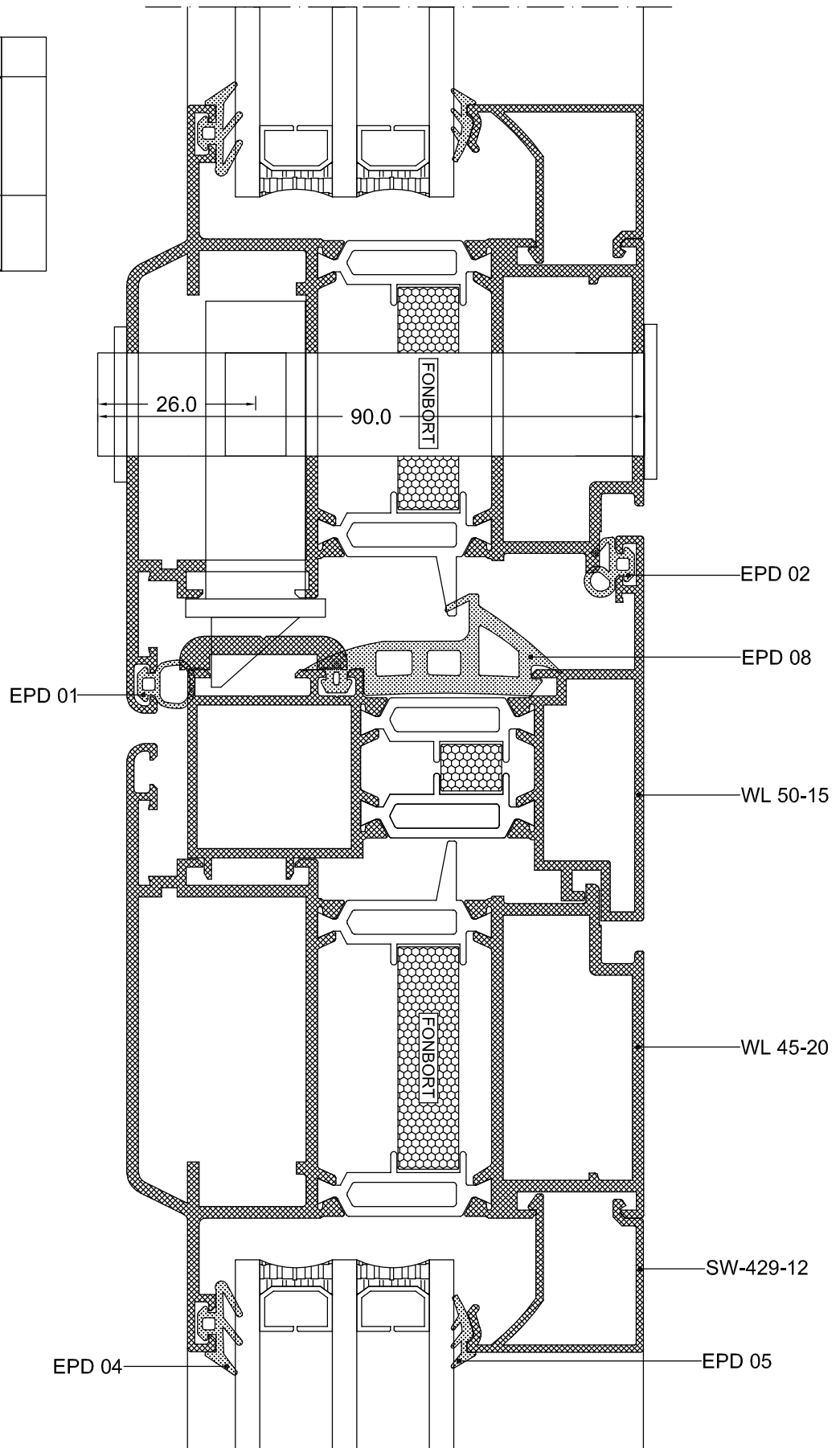

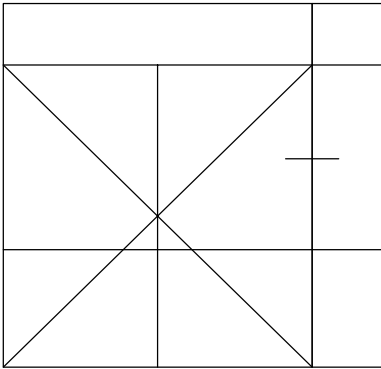

24

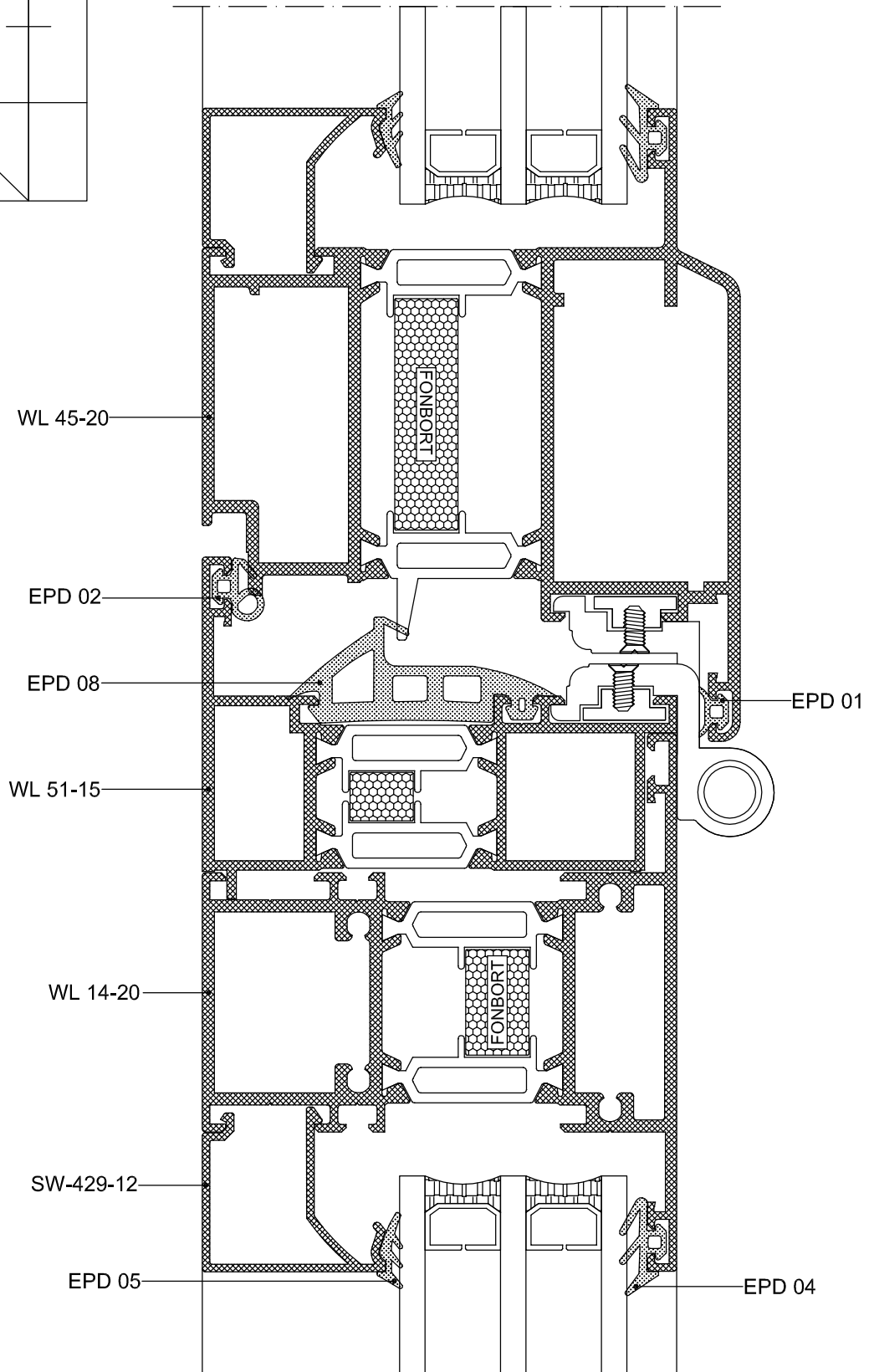

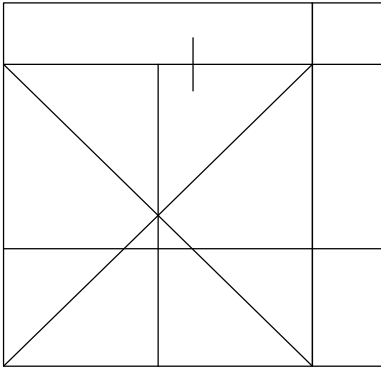

25

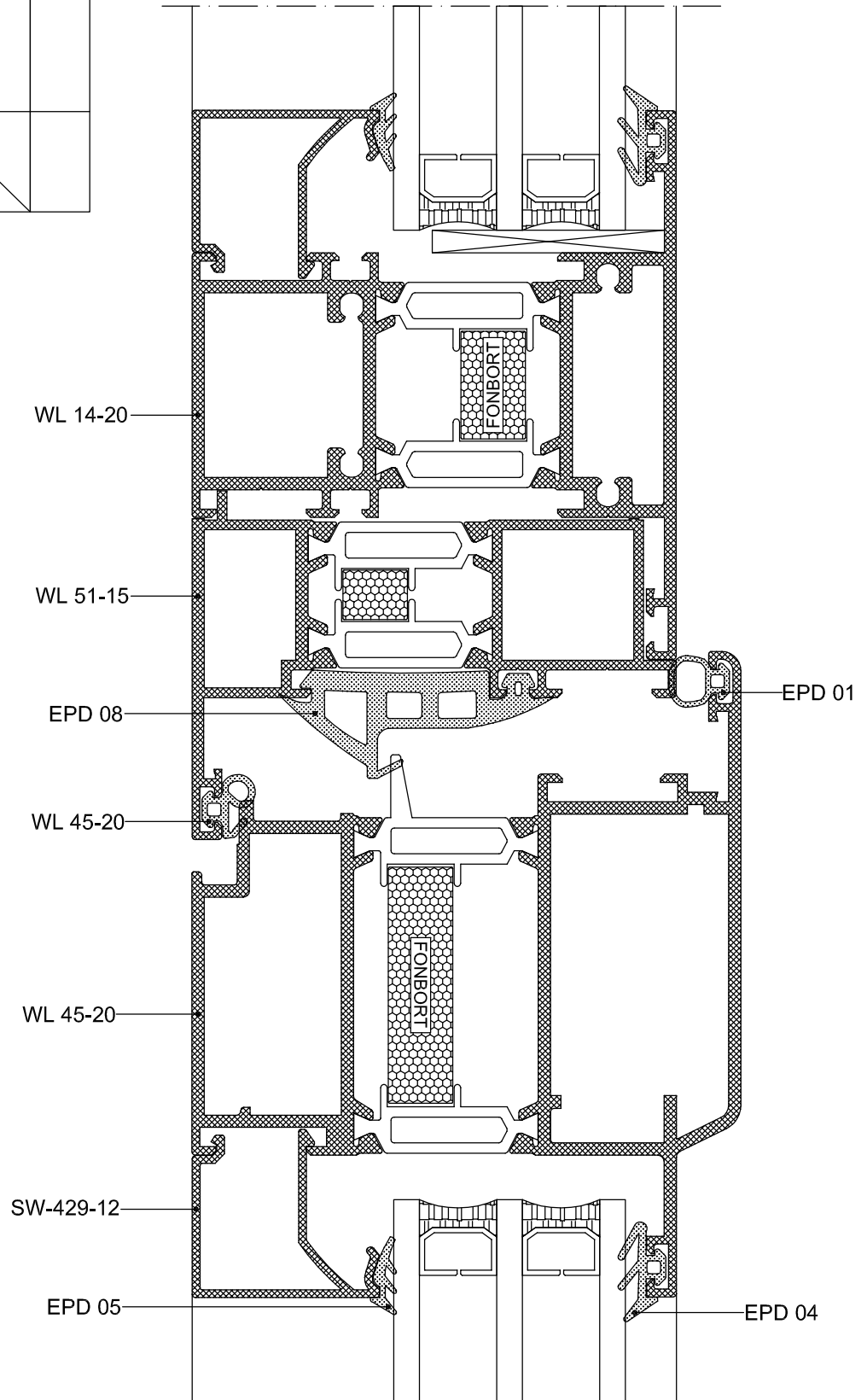

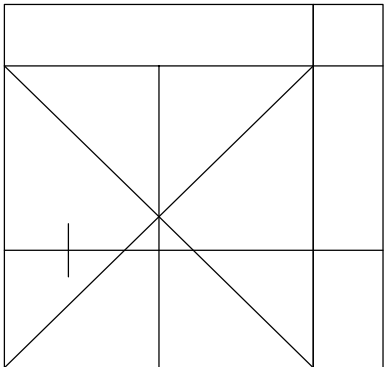

26

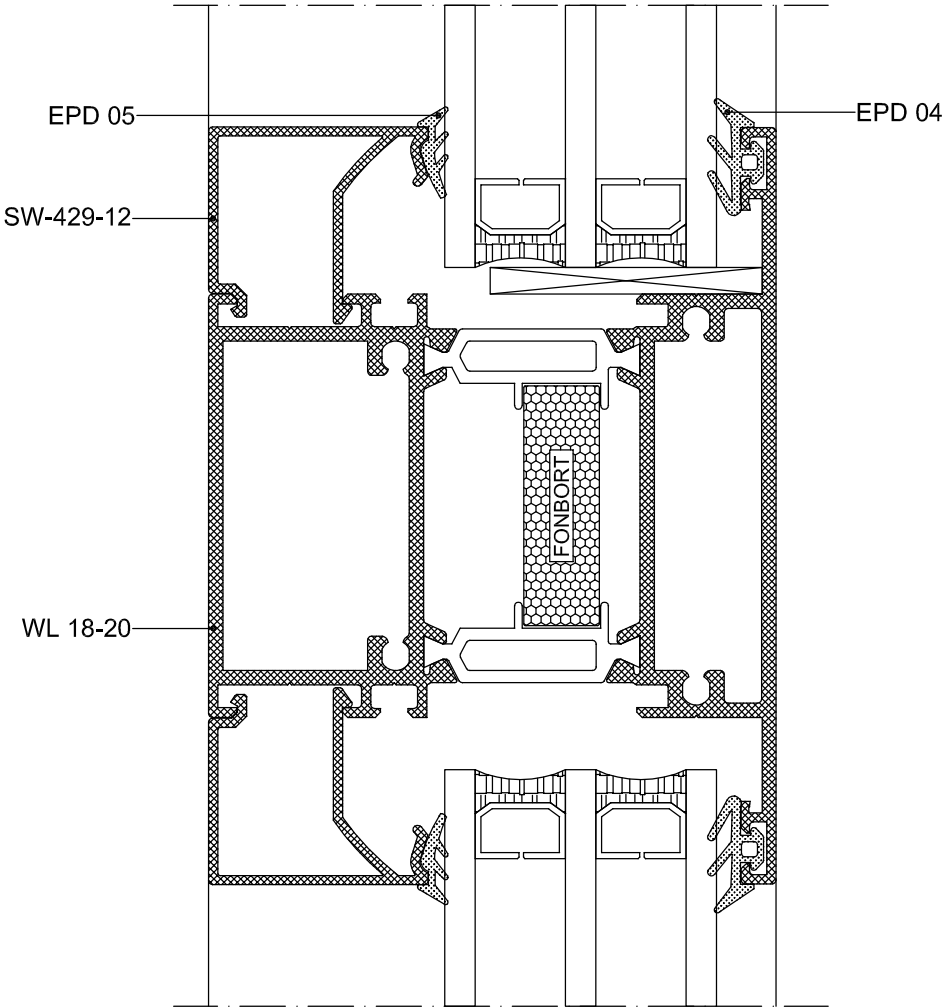

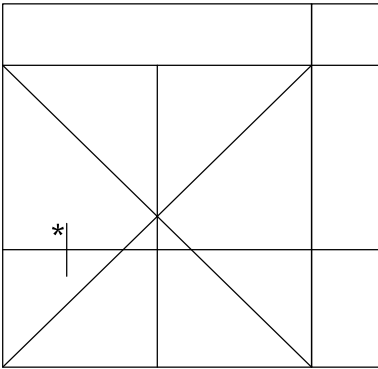

27

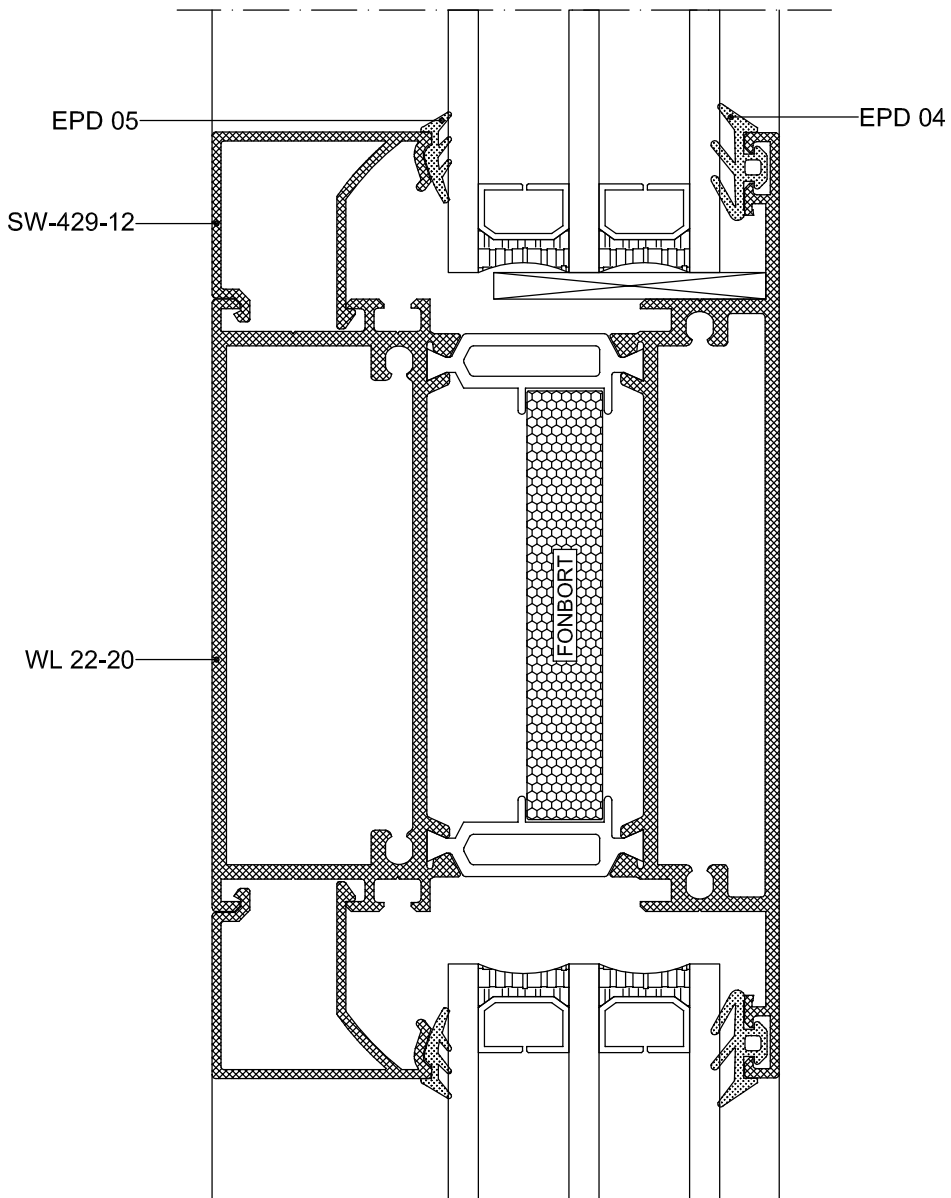

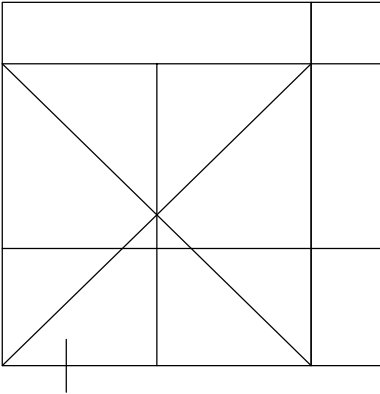

28

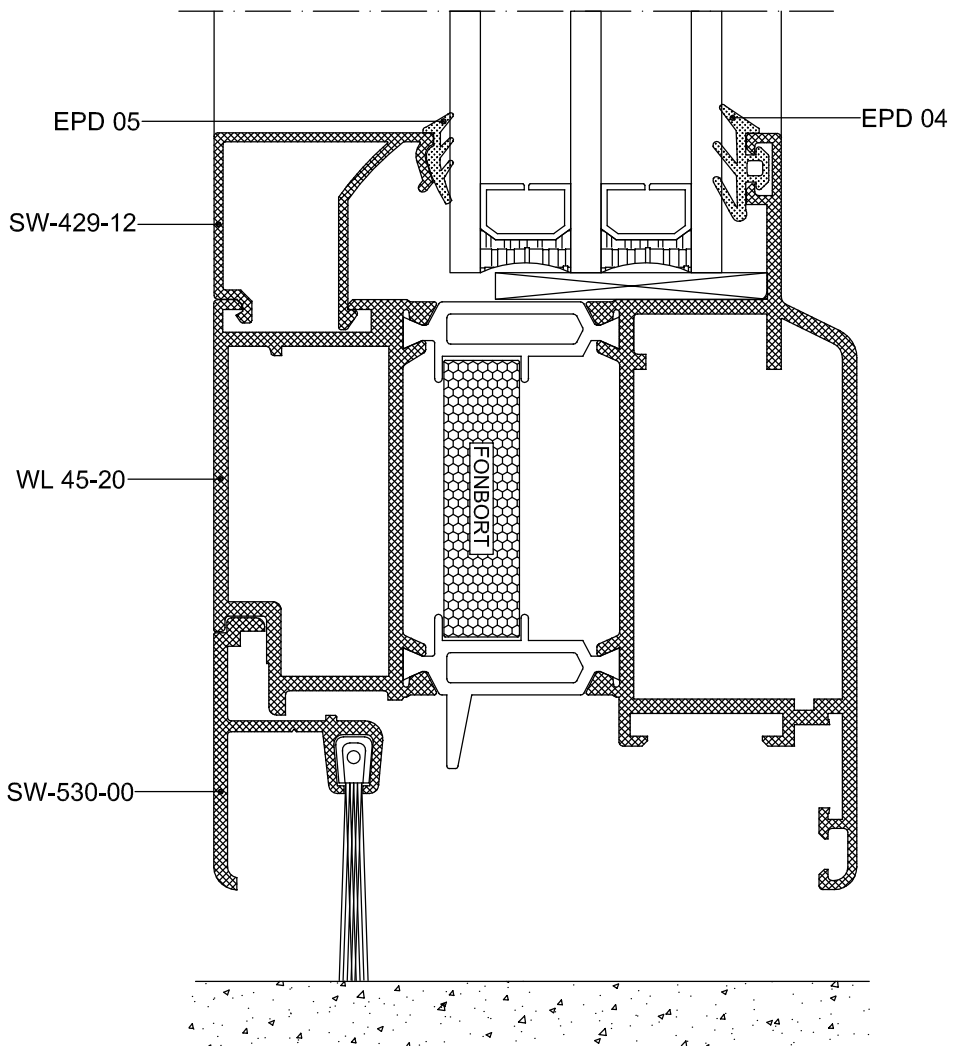

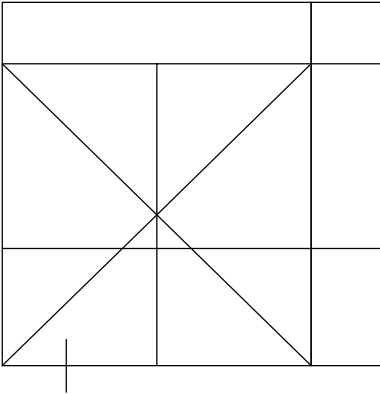

29

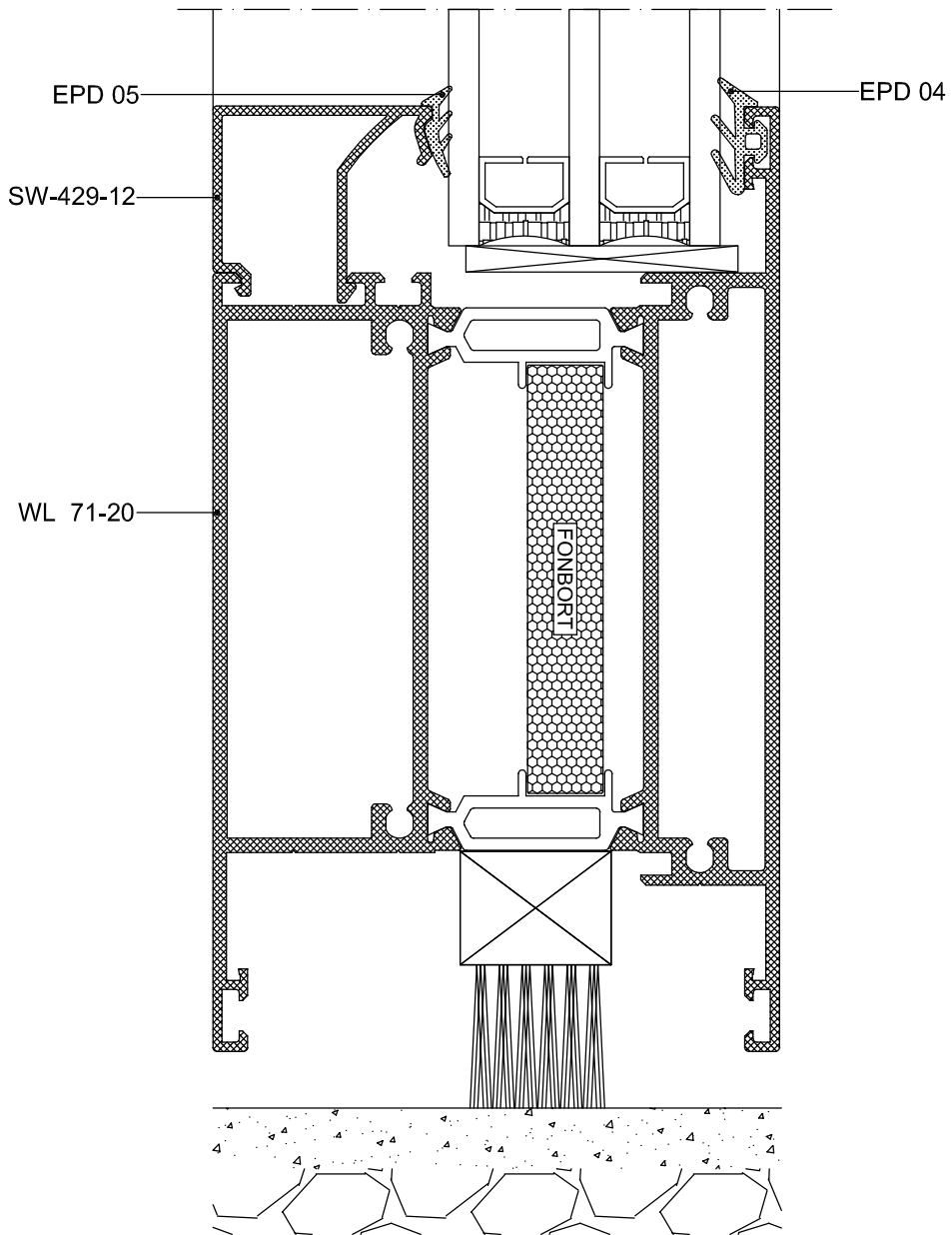

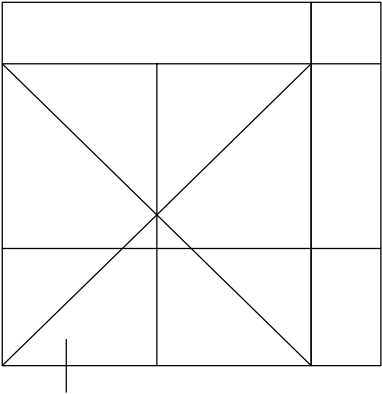

30

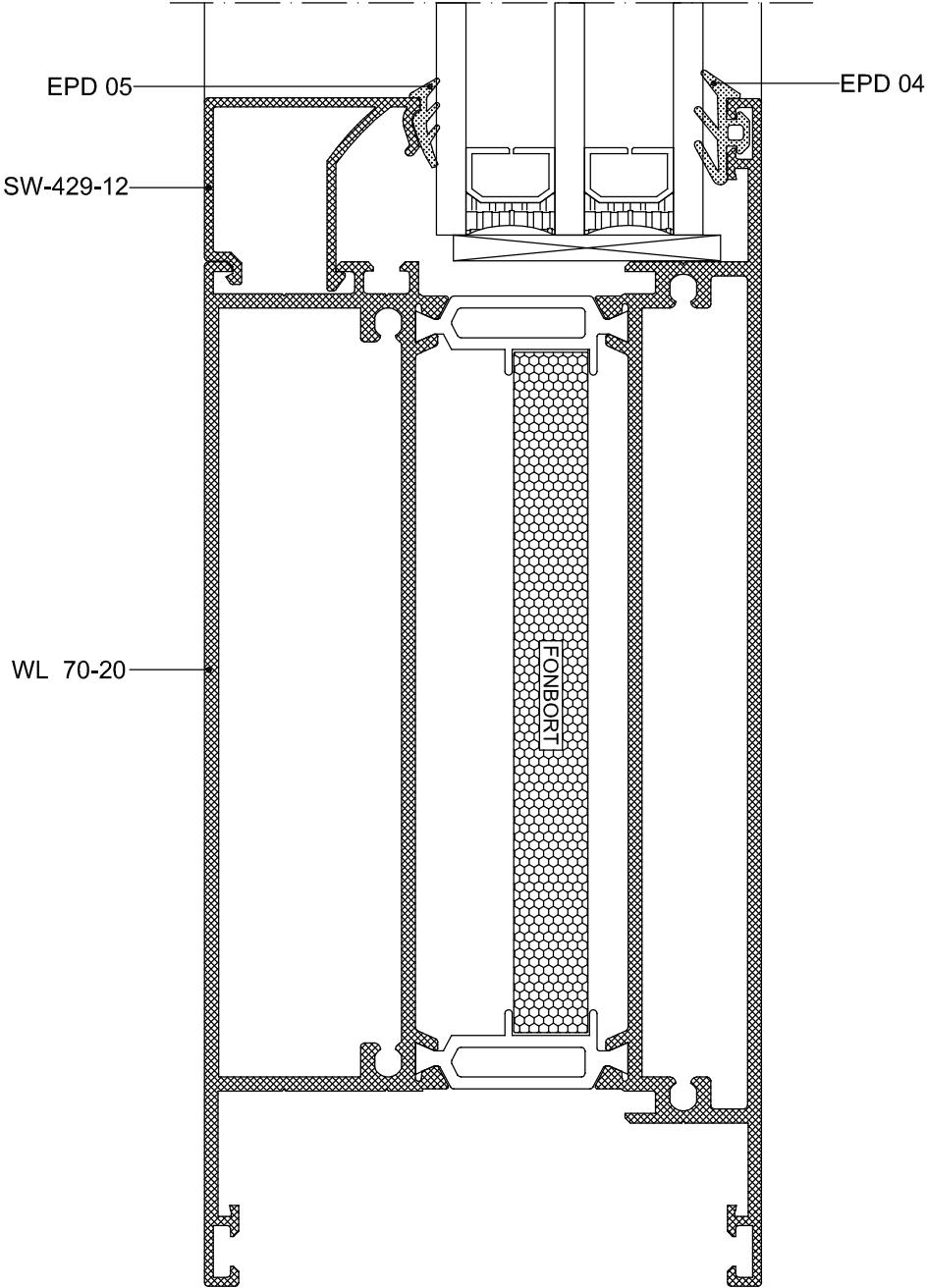

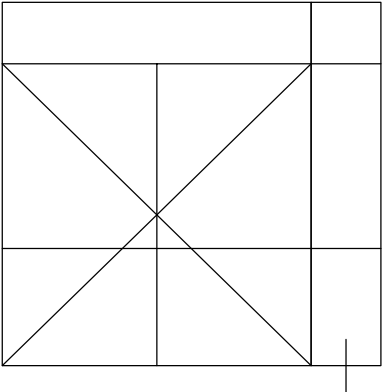

31

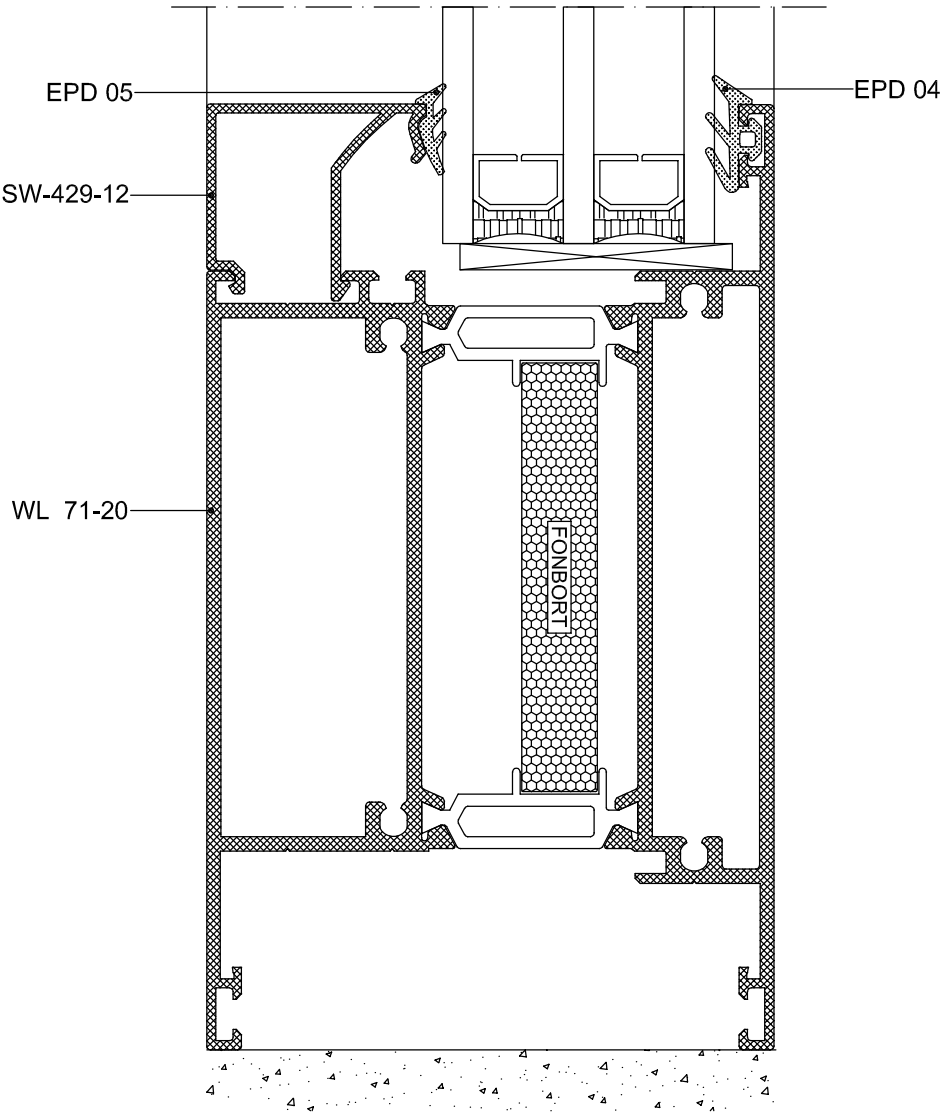

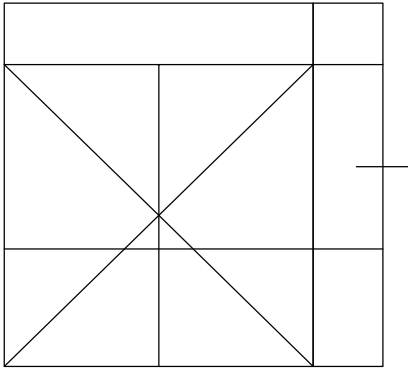

32

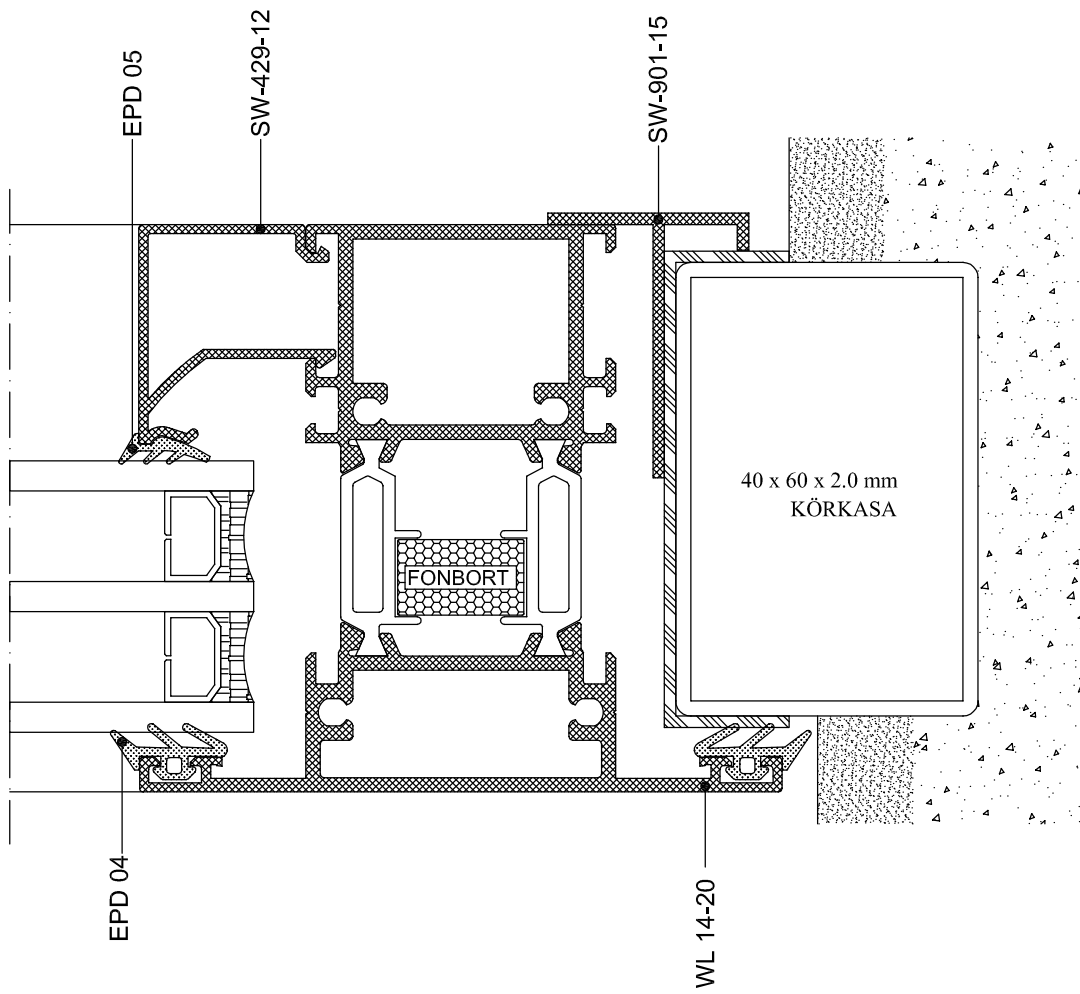



ALUFOUR

YALITIMLI DOĞRAMA SİSTEMİ



ALUFOUR

YALITIMLI DOĞRAMA SİSTEMİ