



YALITIMLI DOĞRAMA SİSTEMİ

**A
Y
-
55
55**

ALUFOUR
DOĞRAMA SİSTEMLERİ



ALUFOUR

YALITIMLI DOĞRAMA SİSTEMİ

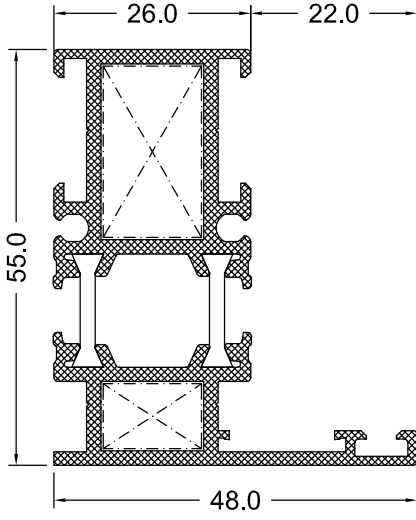

KASA PROFİLİ

PROFİL KODU	AĞIRLIK (kg/m)	KÖŞE GÖNYE	KESİM ÖLÇÜSÜ		I _x	I _y
			ÜST	ALT		
Y-1102-16	1.224	TK-130	22.6 mm	8.6 mm	14.31	4.61
Y-1102-20	1.316	TK-130	22.6 mm	8.6 mm	16.09	5.46

KASA PROFİLİ

PROFİL KODU	AĞIRLIK (kg/m)	KÖŞE GÖNYE	KESİM ÖLÇÜSÜ		I _x	I _y
			ÜST	ALT		
Y-1103-16	1.310	TK-180	22.6 mm	8.6 mm	15.81	6.62
Y-1103-20	1.419	TK-180	22.6 mm	8.6 mm	17.31	6.96

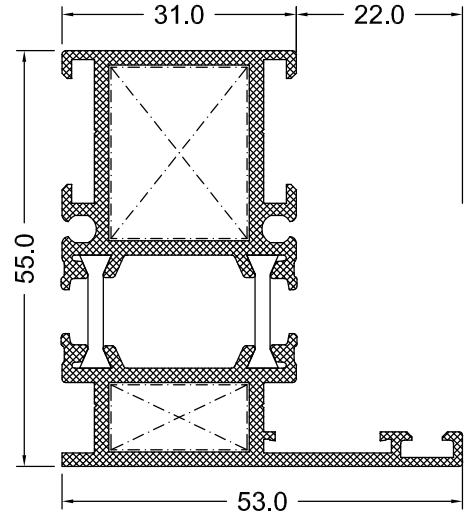

KASA PROFİLİ

PROFİL KODU	AĞIRLIK (kg/m)	KÖŞE GÖNYE	KESİM ÖLÇÜSÜ		I _x	I _y
			ÜST	ALT		
Y-1104-16	1.397	TK-230	22.6 mm	8.6 mm	17.44	9.05
Y-1104-20	1.522	TK-230	22.6 mm	8.6 mm	19.14	9.61

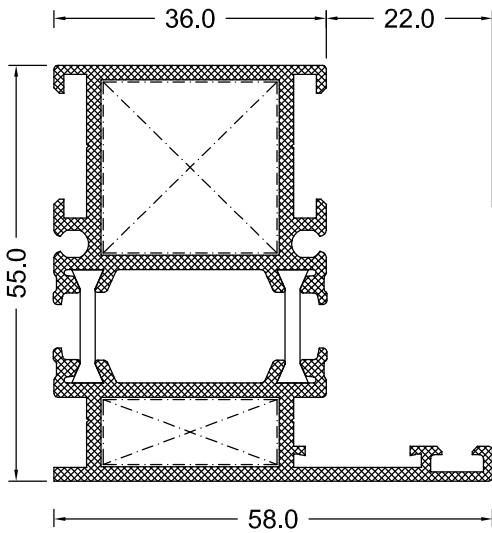

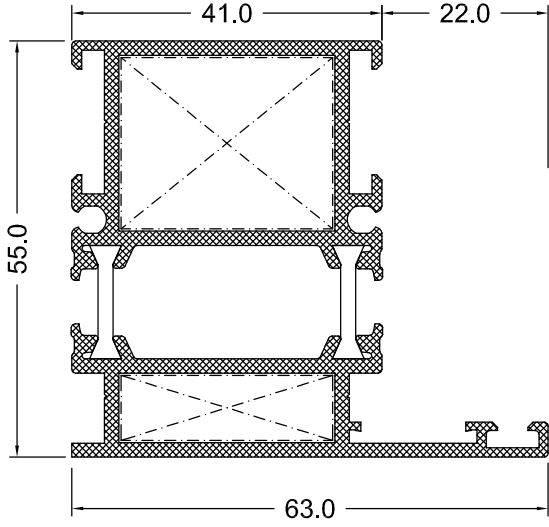

KASA PROFİLİ

PROFİL KODU	AĞIRLIK (kg/m)	KÖŞE GÖNYE	KESİM ÖLÇÜSÜ		I_x	I_y
			ÜST	ALT		
Y-1105-16	1.479	TK-280	22.6 mm	8.6 mm	19.90	12.85
Y-1105-20	1.624	TK-280	22.6 mm	8.6 mm	21.59	13.8

KASA PROFİLİ

PROFİL KODU	AĞIRLIK (kg/m)	KÖŞE GÖNYE	KESİM ÖLÇÜSÜ		I_x	I_y
			ÜST	ALT		
Y-1106-16	1.744	TK-430	22.6 mm	8.6 mm	29.61	19.47
Y-1106-20	1.934	TK-430	22.6 mm	8.6 mm	31.85	21.80

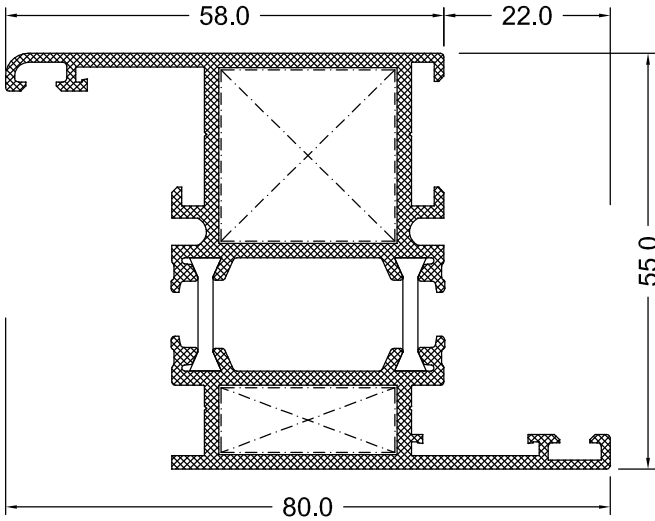
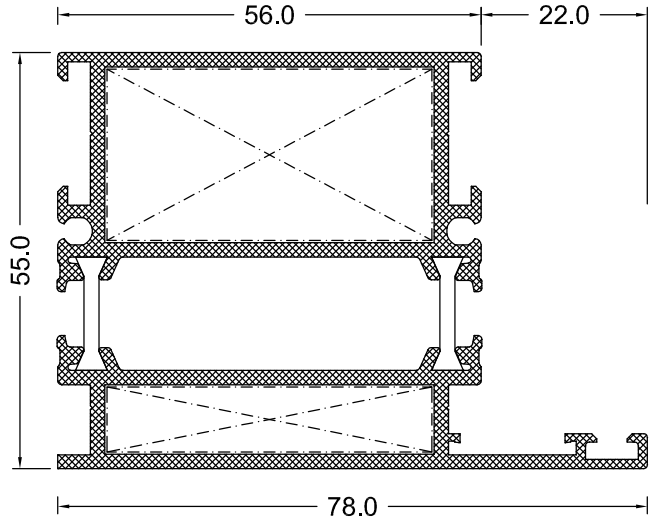

Z KASA PROFİLİ

PROFİL KODU	AĞIRLIK (kg/m)	KÖŞE GÖNYE	KESİM ÖLÇÜSÜ		I_x	I_y
			ÜST	ALT		
Y-1109-20	1.641	TK-230	22.6 mm	8.6 mm	26.44	10.66

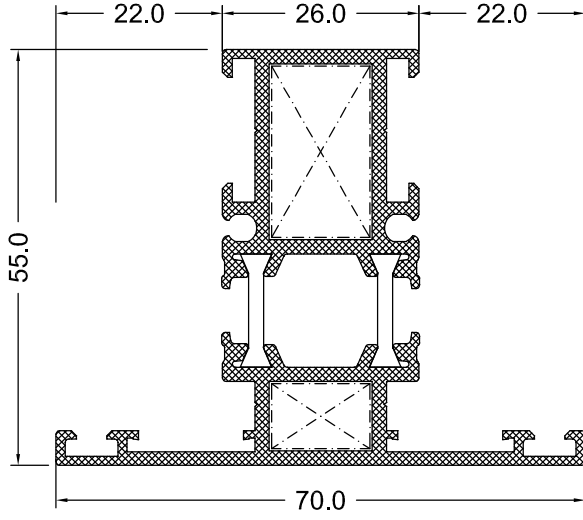

ORTA KAYIT PROFİLİ

PROFİL KODU	AĞIRLIK (kg/m)	KÖŞE GÖNYE	KESİM ÖLÇÜSÜ		I _x	I _y
			ÜST	ALT		
Y-1202-12	1.197	TK-130	22.6 mm	8.6 mm	13.42	8.04
Y-1202-16	1.348	TK-130	22.6 mm	8.6 mm	15.62	8.55
Y-1202-20	1.449	TK-130	22.6 mm	8.6 mm	17.08	8.82

ORTA KAYIT PROFİLİ

PROFİL KODU	AĞIRLIK (kg/m)	KÖŞE GÖNYE	KESİM ÖLÇÜSÜ		I _x	I _y
			ÜST	ALT		
Y-1203-12	1.262	TK-180	22.6 mm	8.6 mm	14.42	10.62
Y-1203-16	1.435	TK-180	22.6 mm	8.6 mm	16.93	11.39
Y-1203-20	1.551	TK-180	22.6 mm	8.6 mm	18.62	11.82

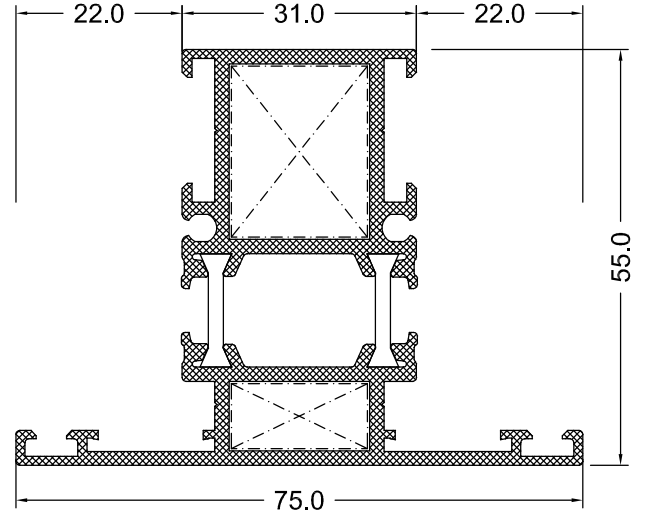

ORTA KAYIT PROFİLİ

PROFİL KODU	AĞIRLIK (kg/m)	KÖŞE GÖNYE	KESİM ÖLÇÜSÜ		I _x	I _y
			ÜST	ALT		
Y-1204-12	1.327	TK-230	22.6 mm	8.6 mm	15.41	13.74
Y-1204-16	1.522	TK-230	22.6 mm	8.6 mm	18.24	14.84
Y-1204-18	1.611	TK-230	22.6 mm	8.6 mm	19.72	16.43
Y-1204-20	1.654	TK-230	22.6 mm	8.6 mm	20.16	15.49

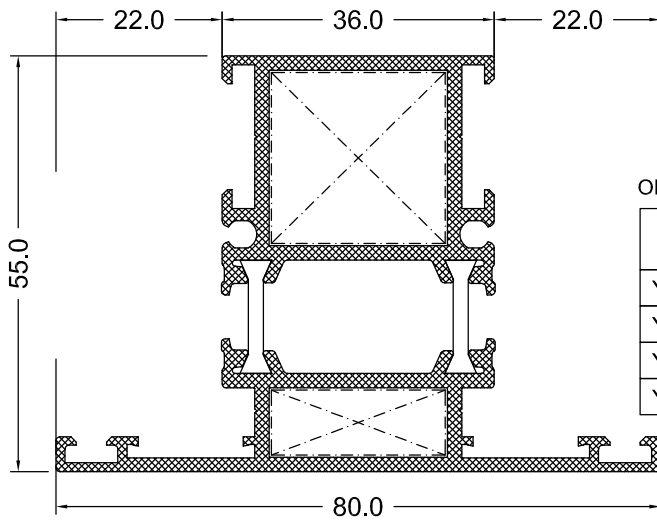

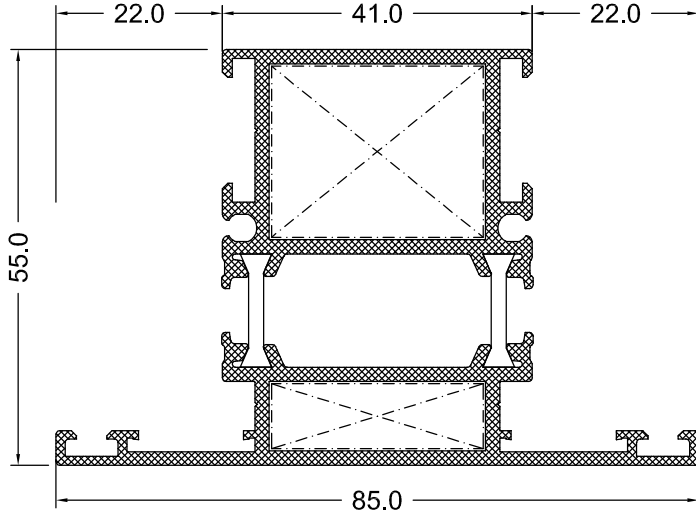

ORTA KAYIT PROFİLİ

PROFİL KODU	AĞIRLIK (kg/m)	KÖŞE GÖNYE	KESİM ÖLÇÜSÜ		I _x	I _y
			ÜST	ALT		
Y-1205-12	1.392	TK-280	22.6 mm	8.6 mm	16.40	17.42
Y-1205-16	1.609	TK-280	22.6 mm	8.6 mm	19.55	18.95
Y-1205-20	1.758	TK-280	22.6 mm	8.6 mm	21.70	19.87

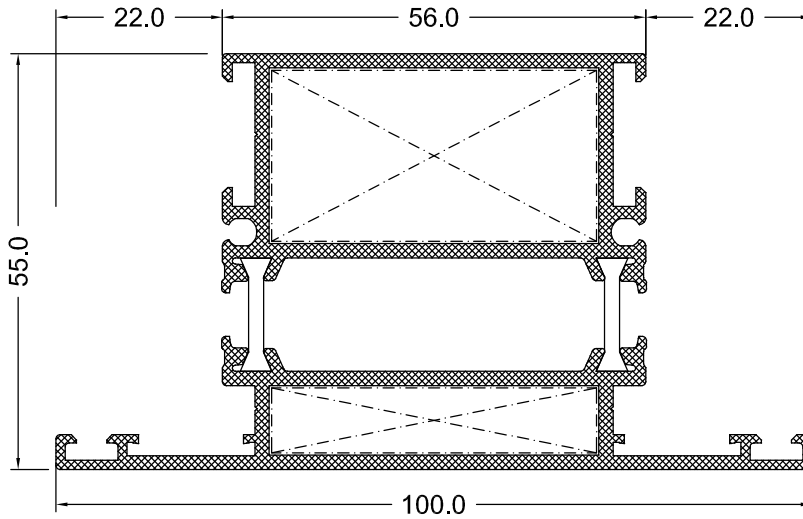

ORTA KAYIT PROFİLİ

PROFİL KODU	AĞIRLIK (kg/m)	KÖŞE GÖNYE	KESİM ÖLÇÜSÜ		I _x	I _y
			ÜST	ALT		
Y-1209-12	1.587	TK-430	22.6 mm	8.6 mm	19.37	32.13
Y-1209-16	1.869	TK-430	22.6 mm	8.6 mm	23.46	35.57
Y-1209-20	2.067	TK-430	22.6 mm	8.6 mm	26.30	37.75

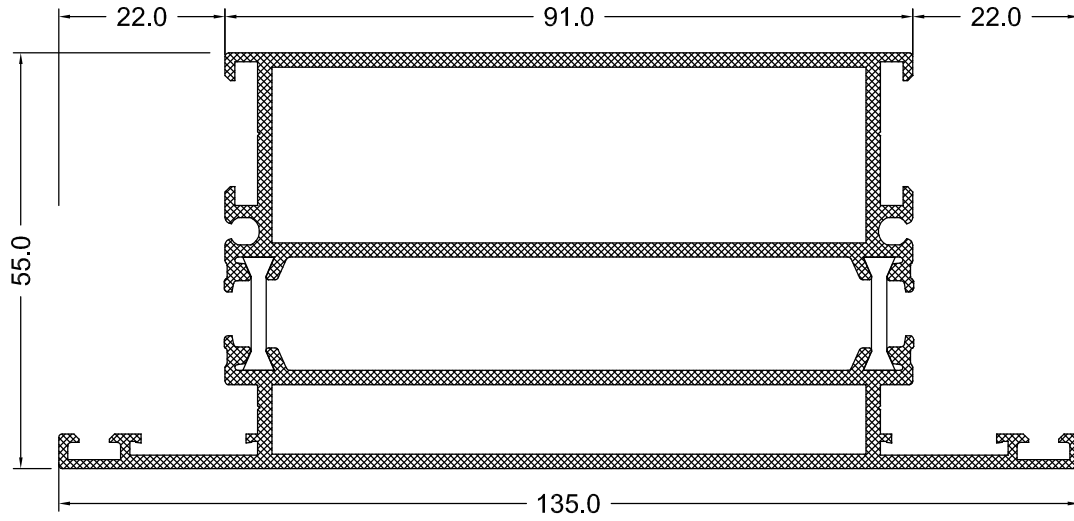

ORTA KAYIT PROFİLİ

PROFİL KODU	AĞIRLIK (kg/m)	KÖŞE GÖNYE	KESİM ÖLÇÜSÜ		I_x	I_y
			ÜST	ALT		
Y-1235-12	2.012	----	----	----	25.85	90.06
Y-1235-16	2.462	----	----	----	32.38	103.90
Y-1235-20	2.788	----	----	----	37.02	113.28

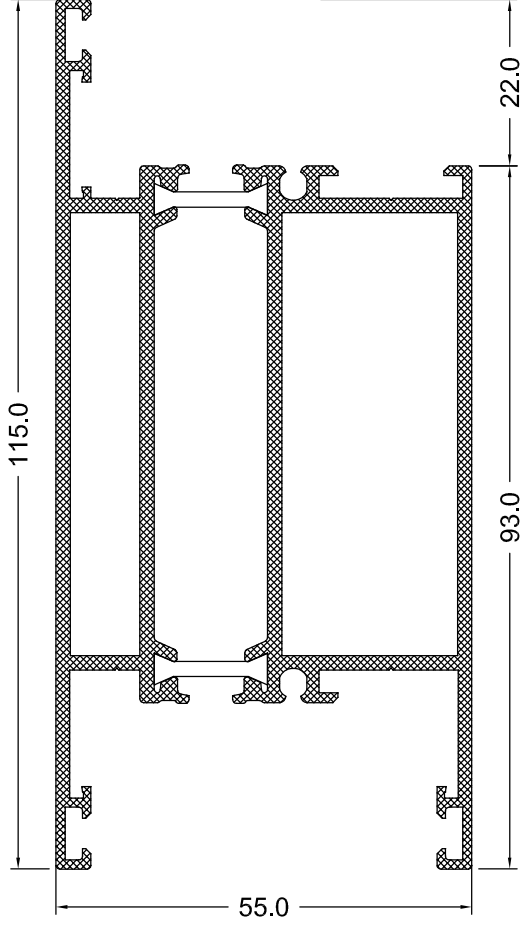

DAR ETEK PROFİLİ

PROFİL KODU	AĞIRLIK (kg/m)	KÖŞE GÖNYE	KESİM ÖLÇÜSÜ		I _x	I _y
			ÜST	ALT		
Y-1152-16	2.229	---	---	---	---	---
Y-1152-20	2.497	---	---	---	---	---

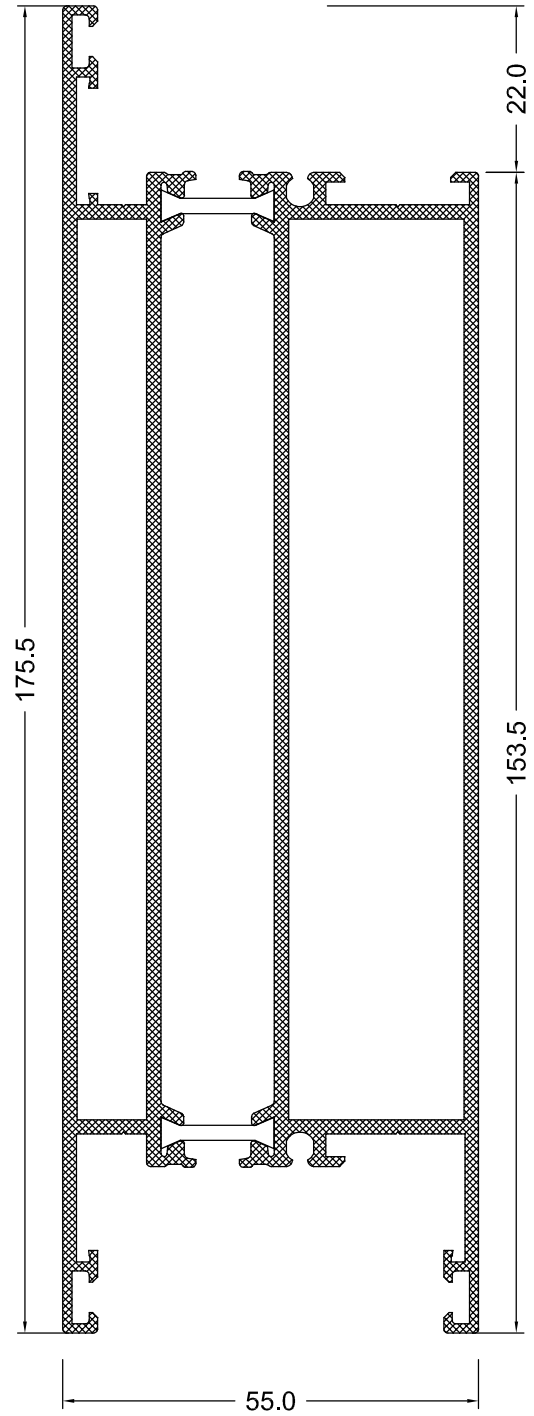

ETEK PROFİLİ

PROFİL KODU	AĞIRLIK (kg/m)	KÖŞE GÖNYE	KESİM ÖLÇÜSÜ		I _x	I _y
			ÜST	ALT		
Y-1175-16	3.168	---	---	---	---	---
Y-1175-20	3.741	---	---	---	---	---

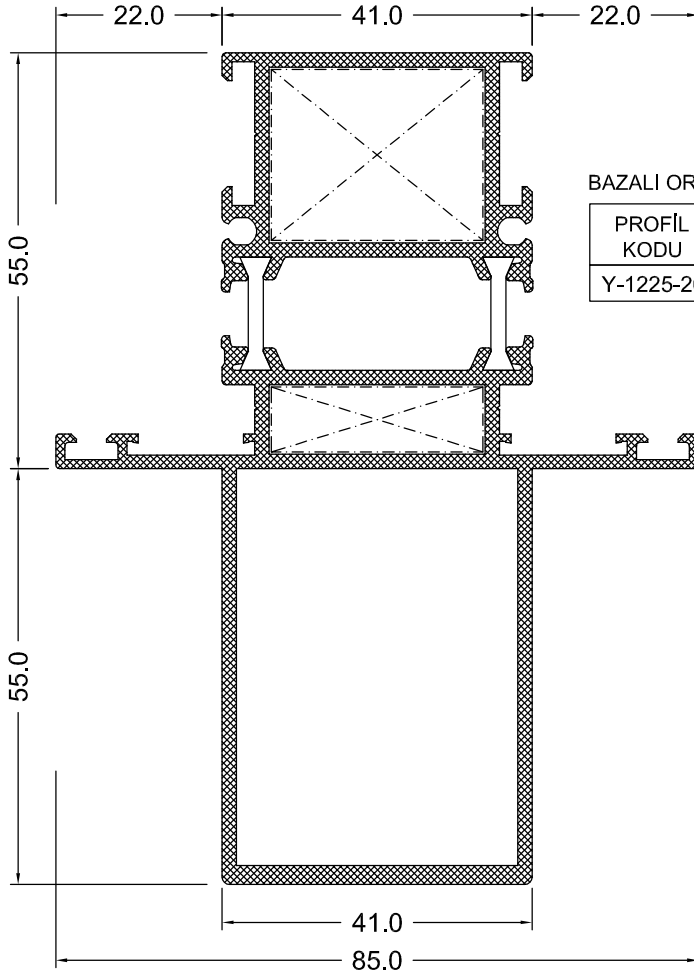

BAZALI ORTA KAYIT PROFİLİ

PROFİL KODU	AĞIRLIK (kg/m)	KÖŞE GÖNYE	KESİM ÖLÇÜSÜ		I_x	I_y
			ÜST	ALT		
Y-1225-20	2.573	TK-280	22.6 mm	8.6 mm	98.24	28.91

BAZALI KASA PROFİLİ

PROFİL KODU	AĞIRLIK (kg/m)	KÖŞE GÖNYE	KESİM ÖLÇÜSÜ		I_x	I_y
			ÜST	ALT		
Y-1226-20	2.443	TK-280	22.6 mm	8.6 mm	98.22	23.57

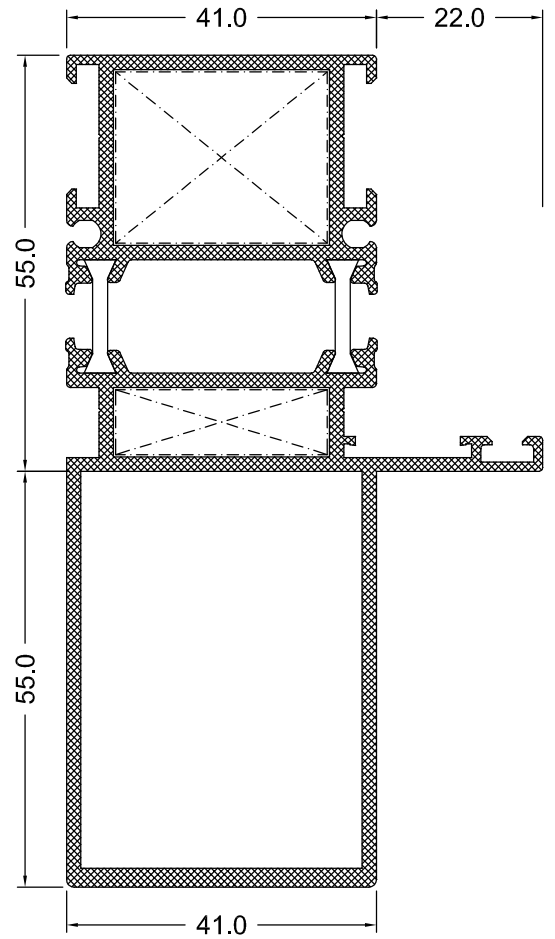

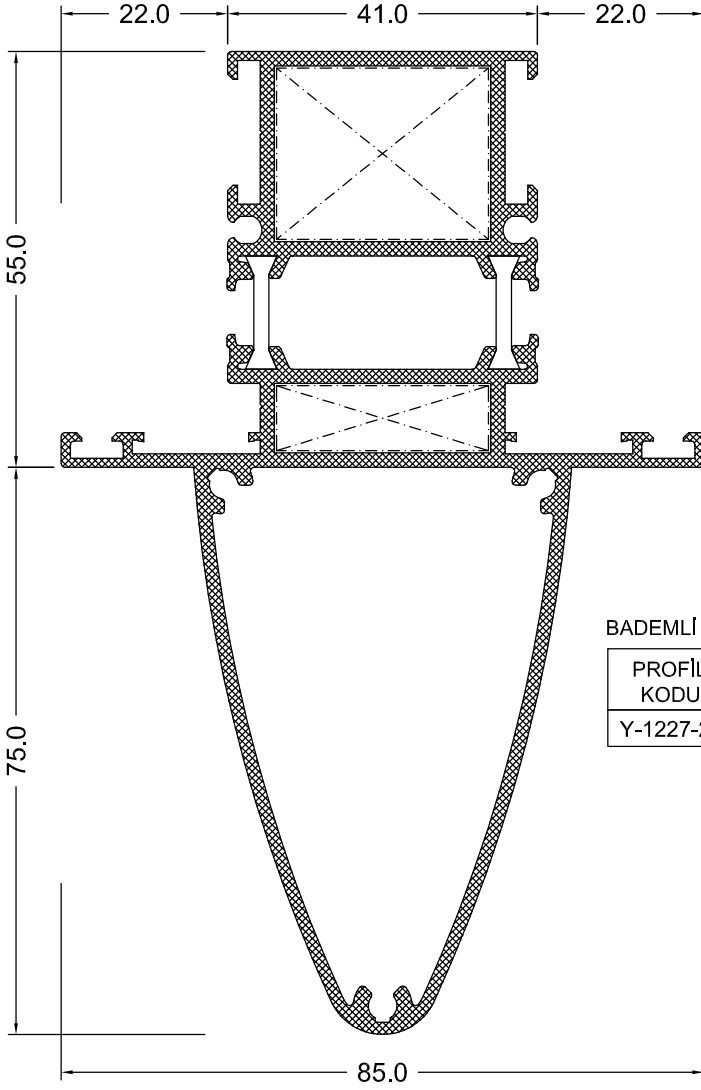

BADEMLİ ORTA KAYIT PROFİLİ

PROFİL KODU	AĞIRLIK (kg/m)	KÖŞE GÖNYE	KESİM ÖLÇÜSÜ		I_x	I_y
			ÜST	ALT		
Y-1227-20	2.608	TK-280	22.6 mm	8.6 mm	113.44	29.09

ÇİFT KANAT ADAPTÖRÜ

PROFİL KODU	AĞIRLIK (kg/m)	KÖŞE GÖNYE	KESİM ÖLÇÜSÜ		I_x	I_y
			ÜST	ALT		
Y-1501-15	1.327	---	---	---	---	---

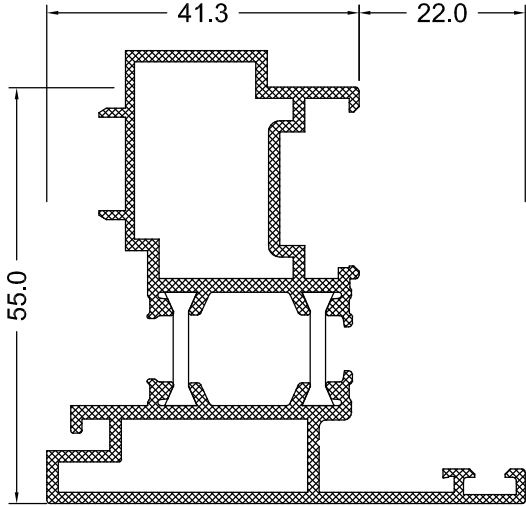
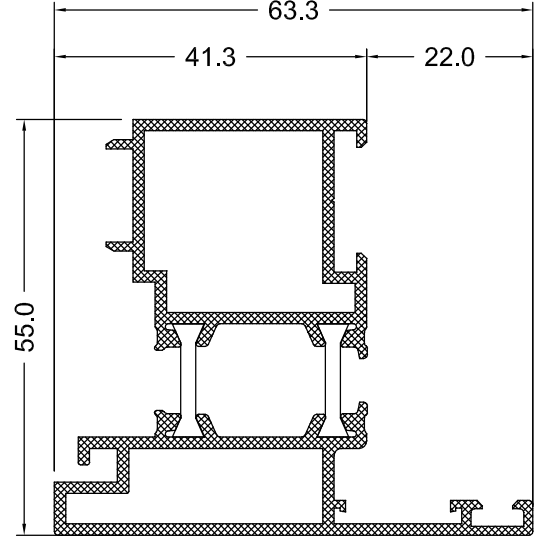

ÇİFT KANAT SÜRGÜ YATAKLI ADAPTÖR

PROFİL KODU	AĞIRLIK (kg/m)	KÖŞE GÖNYE	KESİM ÖLÇÜSÜ		I_x	I_y
			ÜST	ALT		
Y-1502-15	1.389	---	---	---	---	---

DIŐA AÇILIR KAPI ADAPTÖRÜ

PROFİL KODU	AĞIRLIK (kg/m)	KÖŐE GÖNYE	KESİM ÖLÇÜŐÜ		I _x	I _y
			ÜŐT	ALT		
Y-1503-16	1.185	---	---	---	---	---

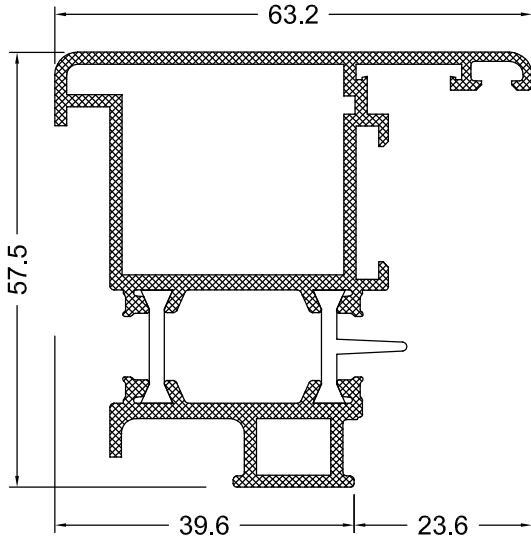
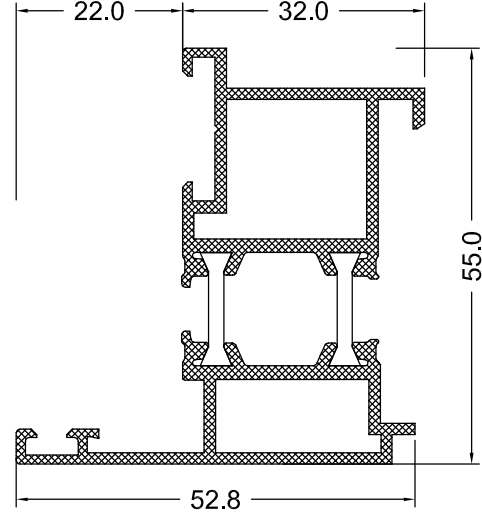

PİVOT AÇILIM ADAPTÖRÜ

PROFİL KODU	AĞIRLIK (kg/m)	KÖŐE GÖNYE	KESİM ÖLÇÜŐÜ		I _x	I _y
			ÜŐT	ALT		
Y-1504-16	1.431	---	---	---	---	---

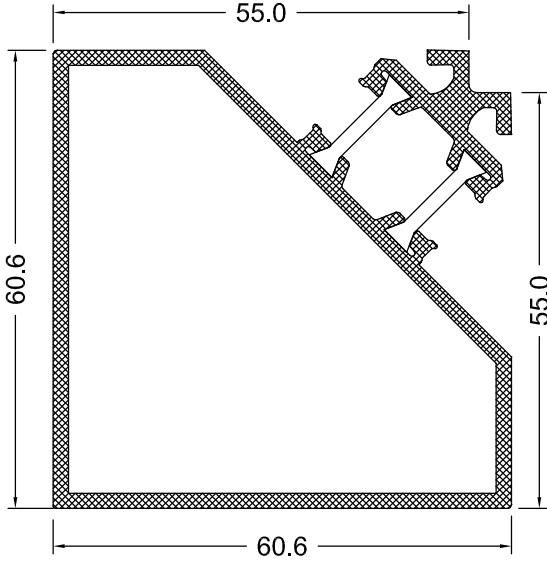

90° OVAL KÖŞE

PROFİL KODU	AĞIRLIK (kg/m)	KÖŞE GÖNYE	KESİM ÖLÇÜSÜ		I _x	I _y
			ÜST	ALT		
Y-1602-15	1.657	---	---	---	---	---

135° OVAL KÖŞE

PROFİL KODU	AĞIRLIK (kg/m)	KÖŞE GÖNYE	KESİM ÖLÇÜSÜ		I _x	I _y
			ÜST	ALT		
Y-1603-16	1.335	---	---	---	---	---

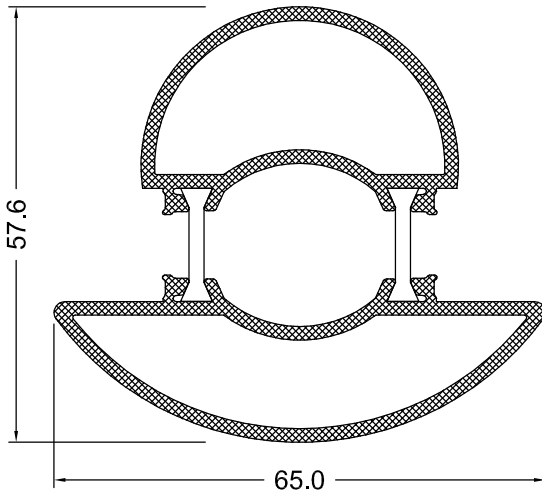
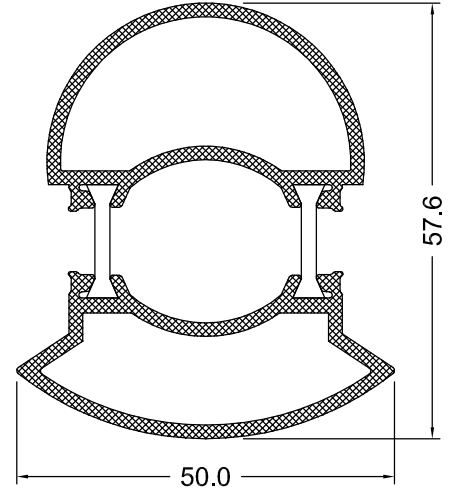

90° DÜZ KÖŞE

PROFİL KODU	AĞIRLIK (kg/m)	KÖŞE GÖNYE	KESİM ÖLÇÜSÜ	I _x	I _y

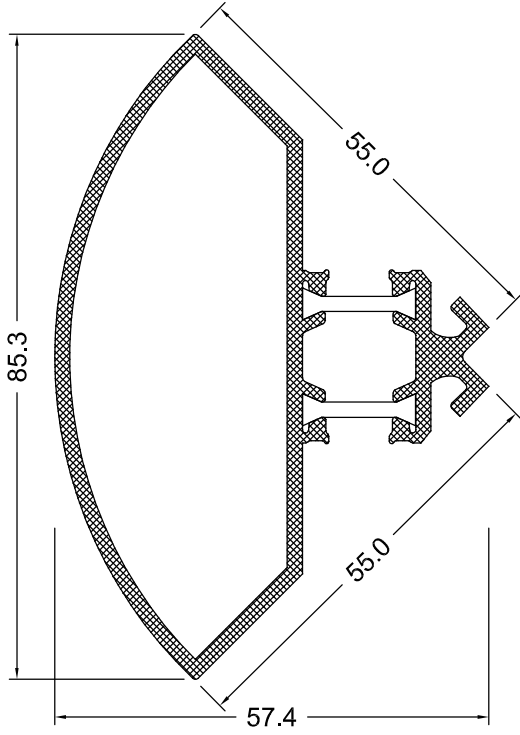

90° OVAL KÖŞE

PROFİL KODU	AĞIRLIK (kg/m)	KÖŞE GÖNYE	KESİM ÖLÇÜSÜ		I _x	I _y
			ÜST	ALT		
Y-1605-15	1.522	---	---	---	---	---

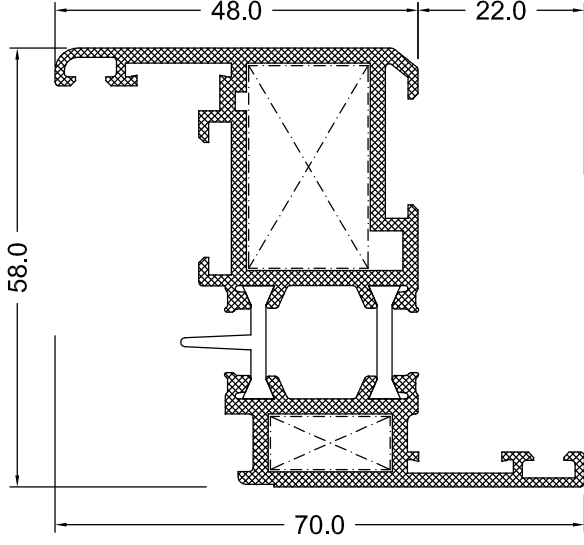

KANAT PROFİLİ

PROFİL KODU	AĞIRLIK (kg/m)	KÖŞE GÖNYE	KESİM ÖLÇÜSÜ		I_x	I_y
			ÜST	ALT		
Y-1302-16	1.398	TK-158	26.8 mm	7.0 mm	----	----
Y-1302-20	1.547	TK-158	26.8 mm	7.0 mm	----	----

KANAT PROFİLİ

PROFİL KODU	AĞIRLIK (kg/m)	KÖŞE GÖNYE	KESİM ÖLÇÜSÜ		I_x	I_y
			ÜST	ALT		
Y-1303-16	1.485	TK-208	26.8 mm	7.0 mm	----	----
Y-1303-20	1.656	TK-208	26.8 mm	7.0 mm	----	----

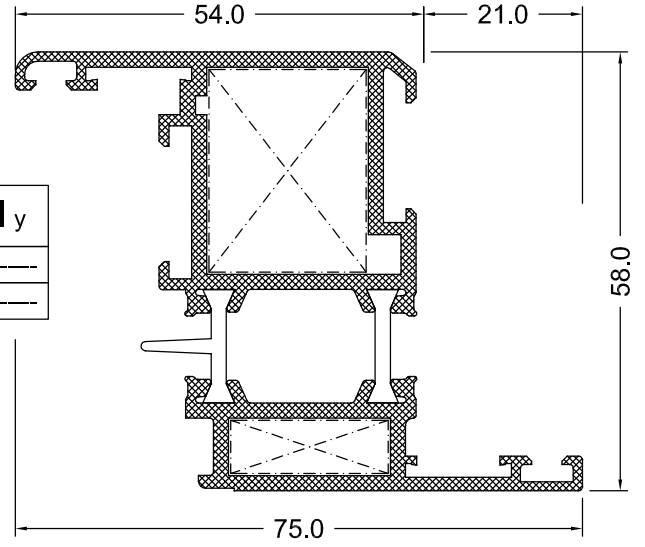

KANAT PROFİLİ

PROFİL KODU	AĞIRLIK (kg/m)	KÖŞE GÖNYE	KESİM ÖLÇÜSÜ		I_x	I_y
			ÜST	ALT		
Y-1304-16	1.572	TK-258	26.8 mm	7.0 mm	----	----
Y-1304-20	1.764	TK-258	26.8 mm	7.0 mm	----	----

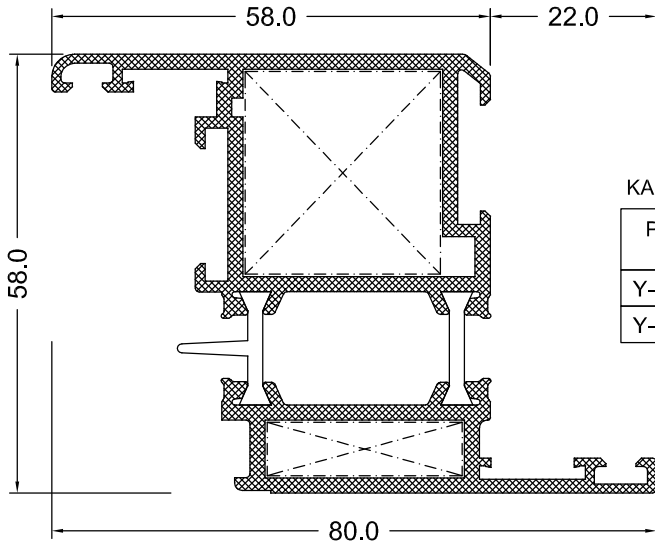

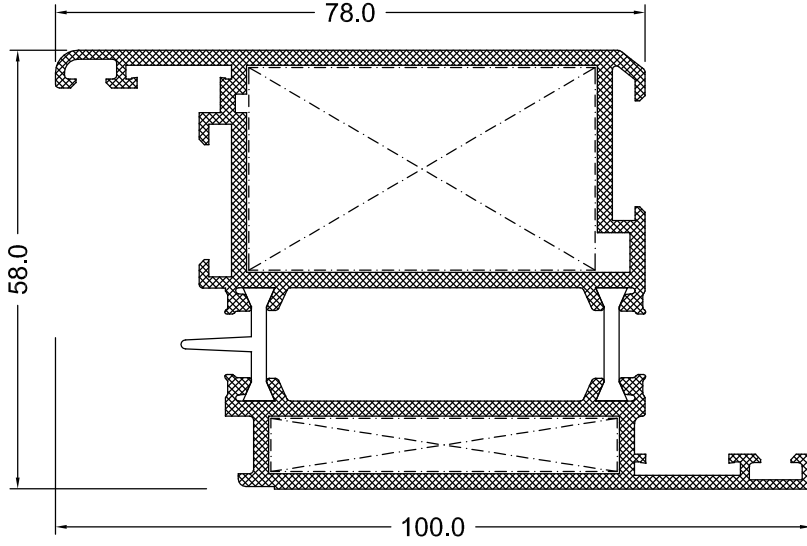

KAPI KANAT PROFİLİ

PROFİL KODU	AĞIRLIK (kg/m)	KÖŞE GÖNYE	KESİM ÖLÇÜSÜ		I _x	I _y
			ÜST	ALT		
Y-1308-16	1.919	TK-458	26.8 mm	7.0 mm	----	----
Y-1308-20	2.198	TK-458	26.8 mm	7.0 mm	----	----

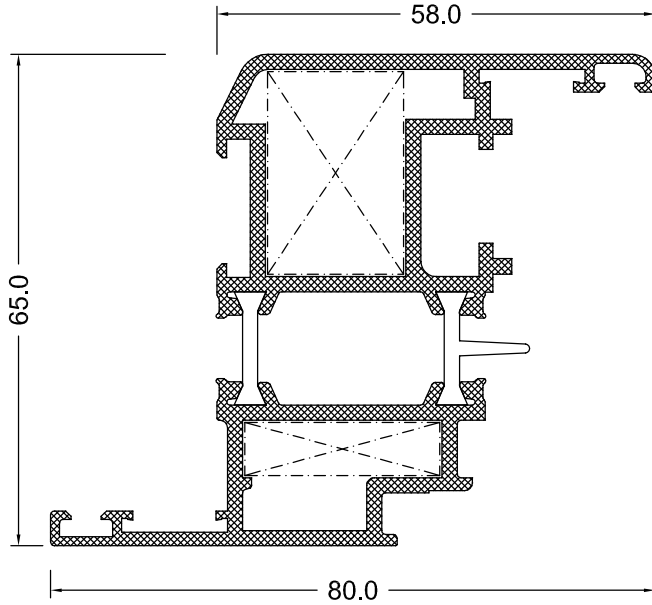

HEMİYÜZ KANAT PROFİLİ

PROFİL KODU	AĞIRLIK (kg/m)	KÖŞE GÖNYE	KESİM ÖLÇÜSÜ		I _x	I _y
			ÜST	ALT		
Y-1361-16	1.669	ÜST TK-180 ALT TK-258	26.8 mm	7.0 mm	----	----
Y-1361-20	1.908	ÜST TK-180 ÜST TK-258	26.8 mm	7.0 mm	----	----

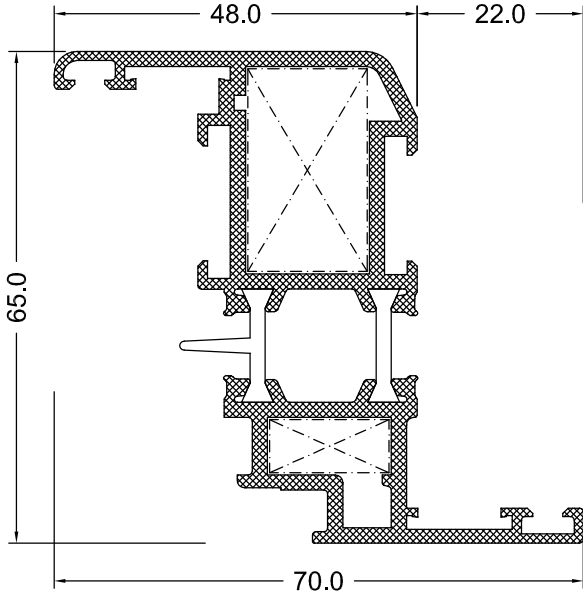

HEMİYÜZ KANAT PROFİLİ

PROFİL KODU	AĞIRLIK (kg/m)	KÖŞE GÖNYE	KESİM ÖLÇÜSÜ		I _x	I _y
			ÜST	ALT		
Y-1332-16	1.442	TK-158	26.8 mm	7.0 mm	----	----
Y-1332-20	1.620	TK-158	26.8 mm	7.0 mm	----	----

HEMİYÜZ KANAT PROFİLİ

PROFİL KODU	AĞIRLIK (kg/m)	KÖŞE GÖNYE	KESİM ÖLÇÜSÜ		I _x	I _y
			ÜST	ALT		
Y-1333-16	1.528	TK-208	26.8 mm	7.0 mm	----	----
Y-1333-18	1.633	TK-208	26.8 mm	7.0 mm	----	----
Y-1333-20	1.728	TK-208	26.8 mm	7.0 mm	----	----

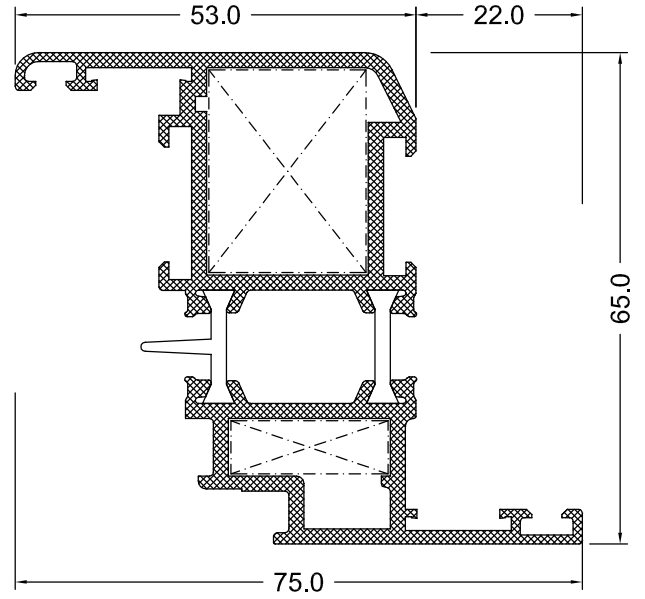

HEMİYÜZ KANAT PROFİLİ

PROFİL KODU	AĞIRLIK (kg/m)	KÖŞE GÖNYE	KESİM ÖLÇÜSÜ		I _x	I _y
			ÜST	ALT		
Y-1334-16	1.615	TK-258	26.8 mm	7.0 mm	----	----
Y-1334-20	1.837	TK-258	26.8 mm	7.0 mm	----	----

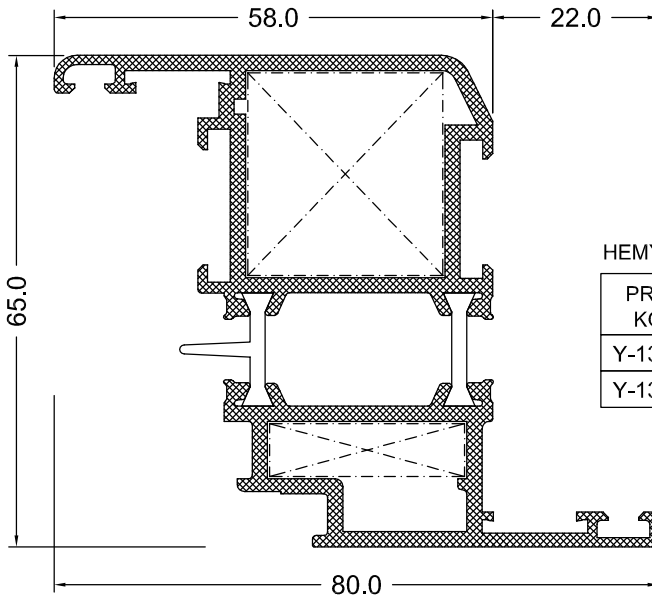

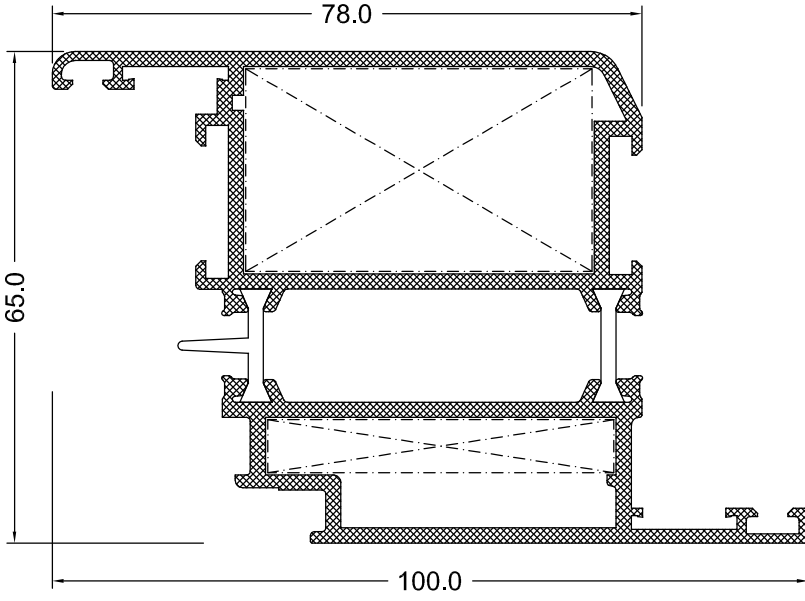

HEMYÜZ KAPI KANAT PROFİLİ

PROFİL KODU	AĞIRLIK (kg/m)	KÖŞE GÖNYE	KESİM ÖLÇÜSÜ		I _x	I _y
			ÜST	ALT		
Y-1338-16	1.962	TK-458	26.8 mm	7.0 mm	----	----
Y-1338-20	2.270	TK-458	26.8 mm	7.0 mm	----	----

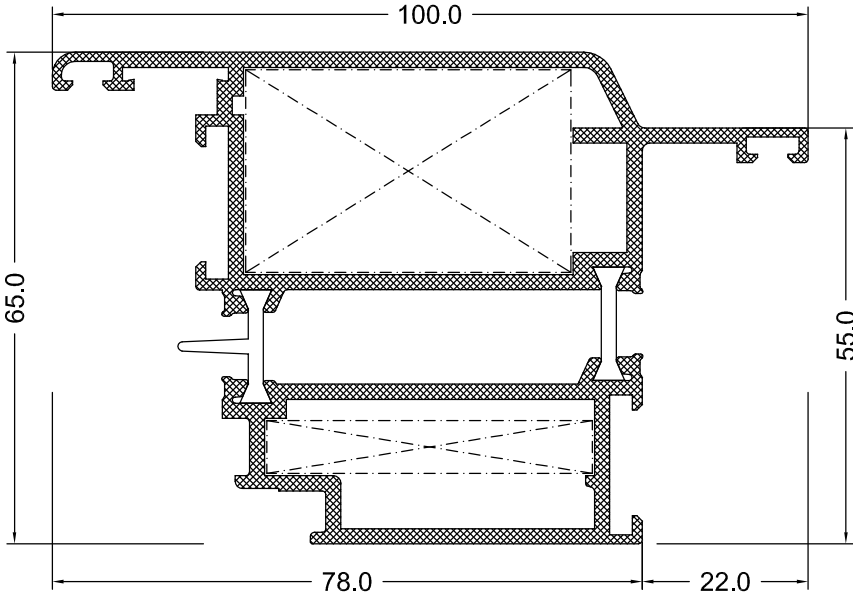

HEMYÜZ DIŞA AÇILIR KAPI KANAT PROFİLİ

PROFİL KODU	AĞIRLIK (kg/m)	KÖŞE GÖNYE	KESİM ÖLÇÜSÜ		I _x	I _y
			ÜST	ALT		
Y-1352-16	2.003	TK-430	26.8 mm	7.0 mm	----	----
Y-1352-20	2.290	TK-430	26.8 mm	7.0 mm	----	----

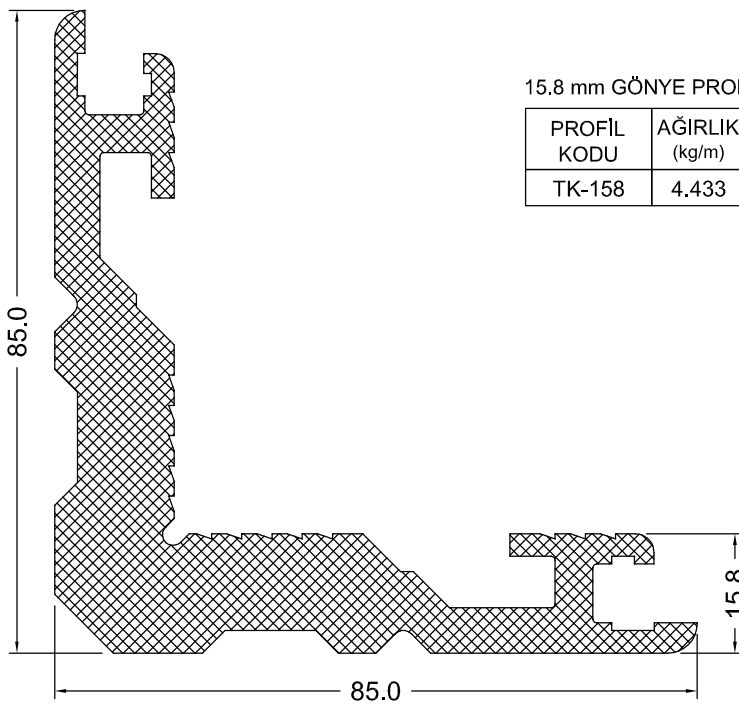
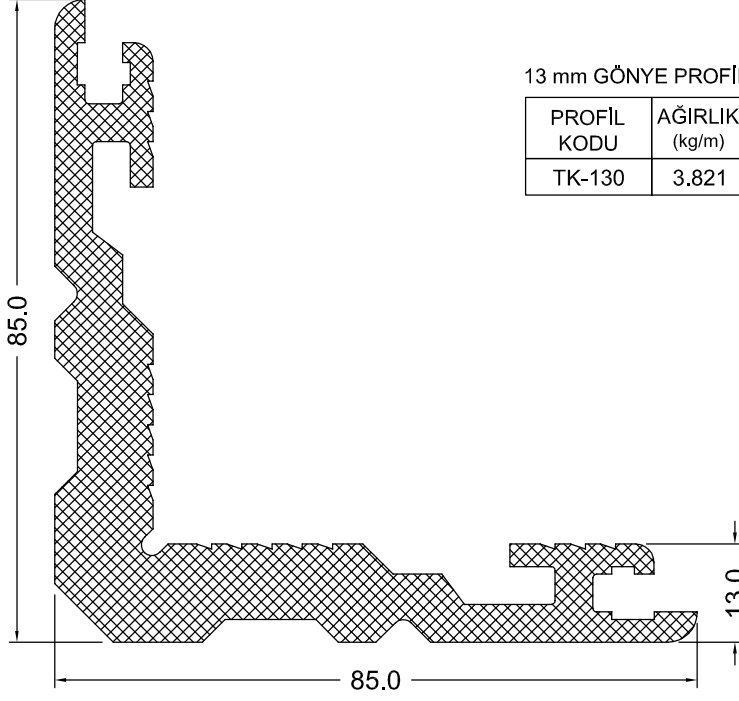

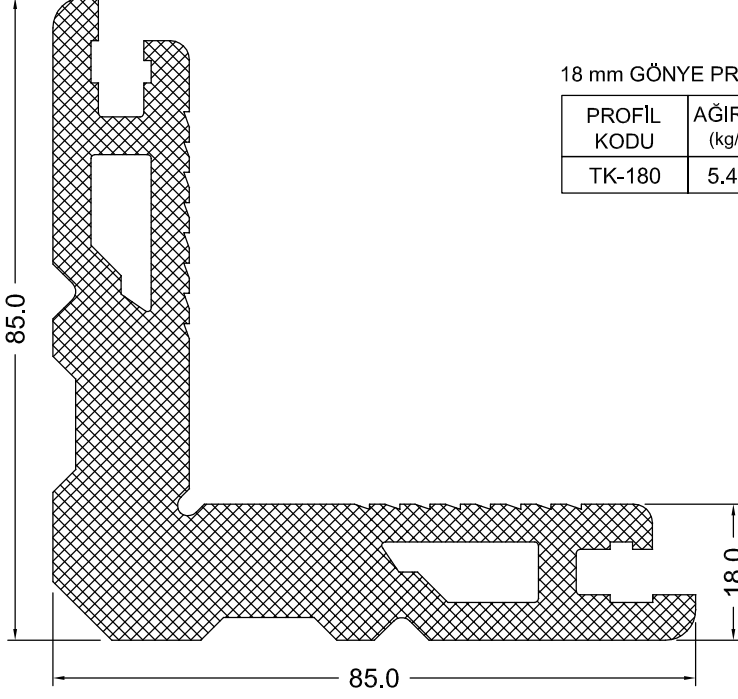

18 mm GÖNYE PROFİLİ

PROFİL KODU	AĞIRLIK (kg/m)	KÖŞE GÖNYE	KESİM ÖLÇÜSÜ		I _x	I _y
			ÜST	ALT		
TK-180	5,474	---	---	---	---	---

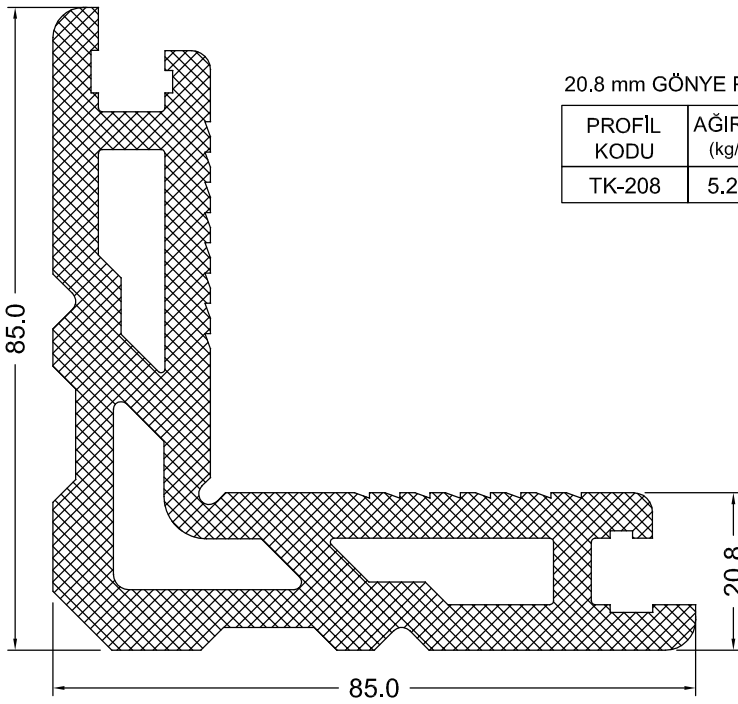

20.8 mm GÖNYE PROFİLİ

PROFİL KODU	AĞIRLIK (kg/m)	KÖŞE GÖNYE	KESİM ÖLÇÜSÜ		I _x	I _y
			ÜST	ALT		
TK-208	5,225	---	---	---	---	---

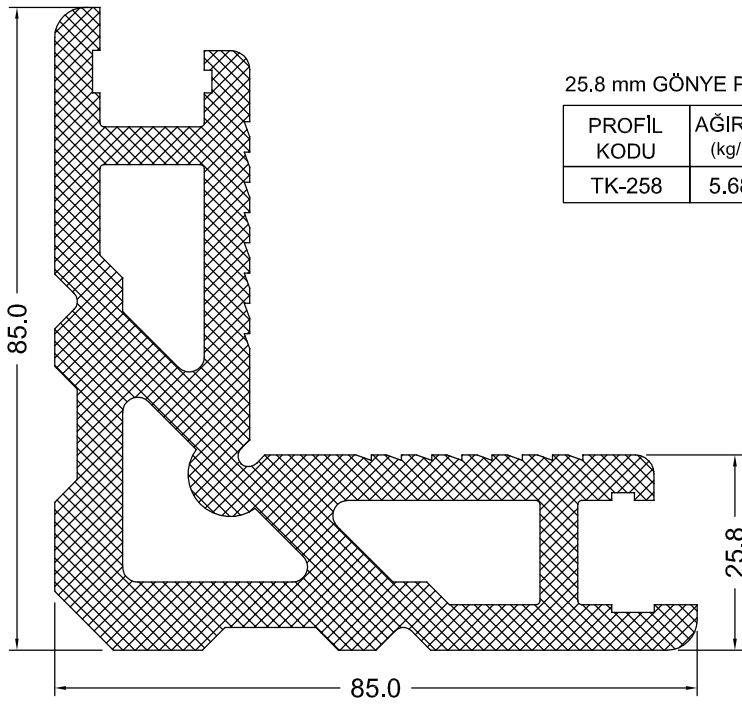
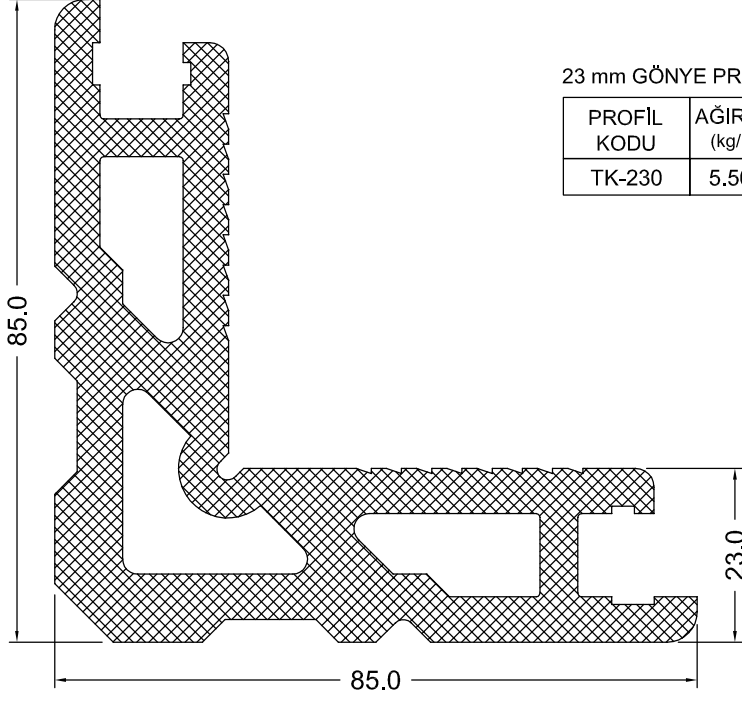

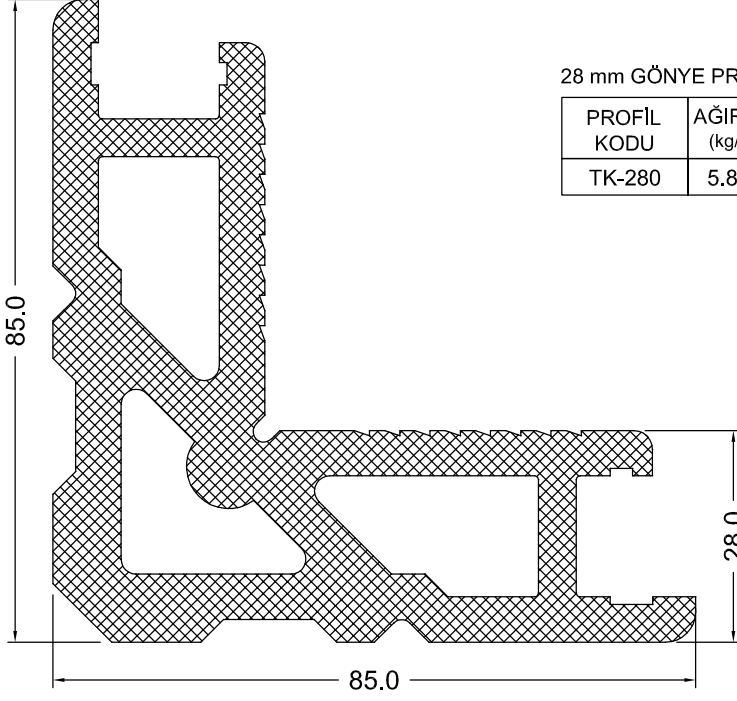

28 mm GÖNYE PROFİLİ

PROFİL KODU	AĞIRLIK (kg/m)	KÖŞE GÖNYE	KESİM ÖLÇÜSÜ		I _x	I _y
			ÜST	ALT		
TK-280	5.816	---	---	---	---	---

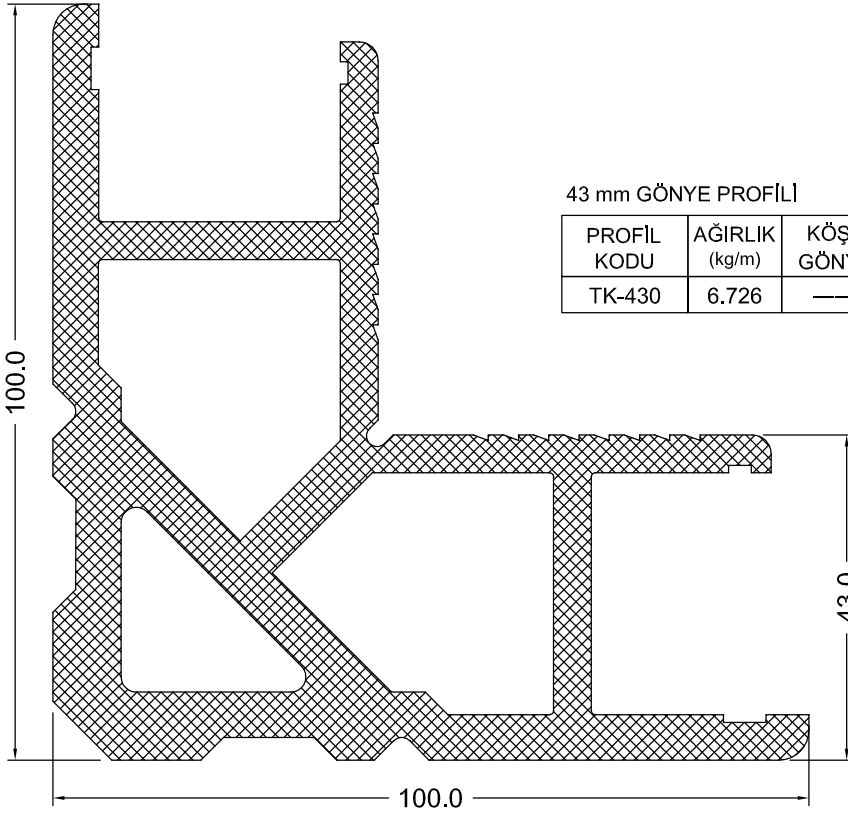

43 mm GÖNYE PROFİLİ

PROFİL KODU	AĞIRLIK (kg/m)	KÖŞE GÖNYE	KESİM ÖLÇÜSÜ		I _x	I _y
			ÜST	ALT		
TK-430	6.726	---	---	---	---	---

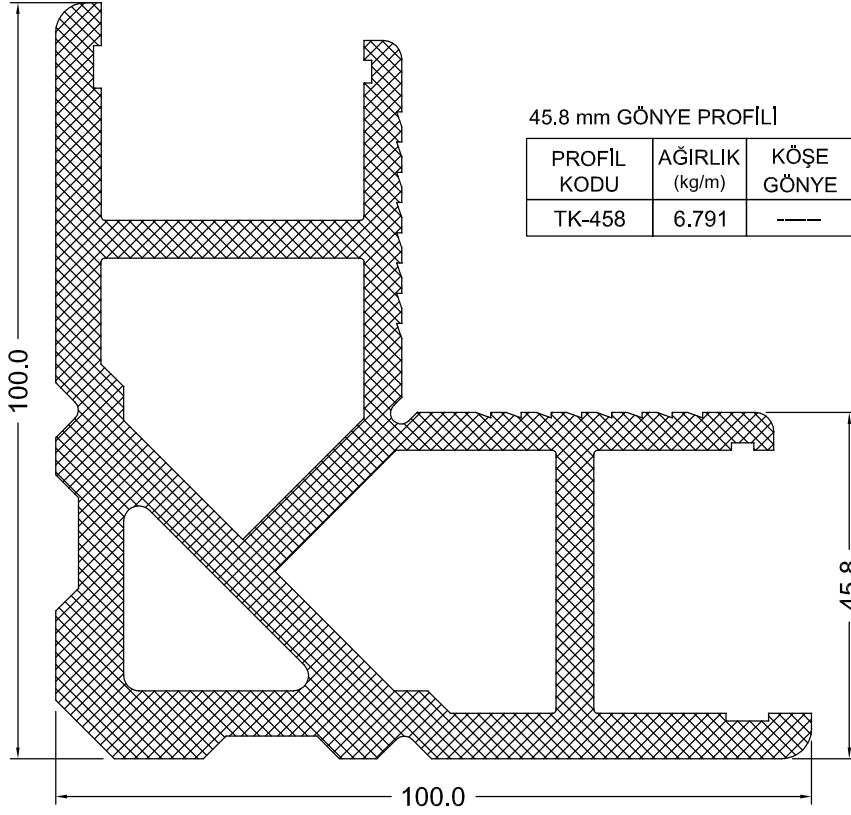

KAPILAR İÇİN FIRÇALIK PROFİLİ

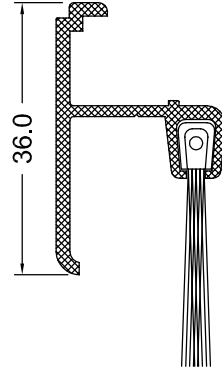

PROFİL KODU	AĞIRLIK (kg/m)
SW-530-00	0.344

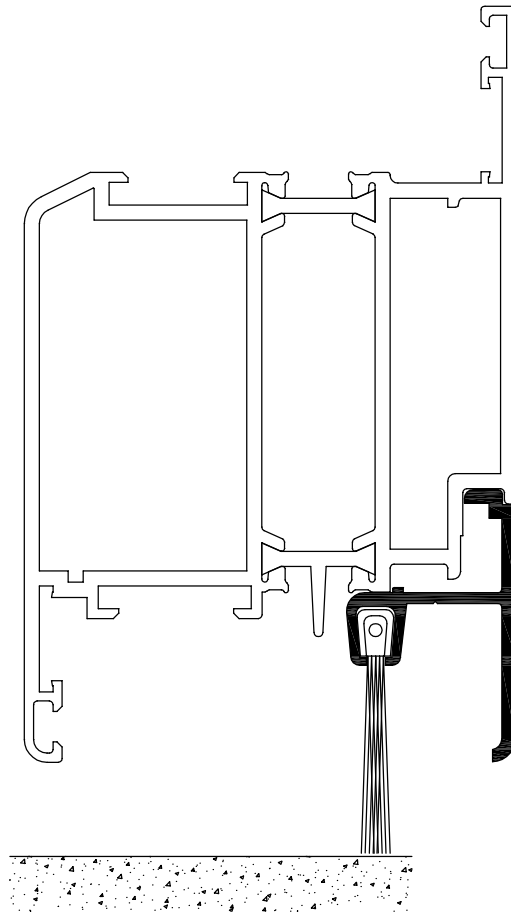

ETEKLER İÇİN FIRÇALIK PROFİLİ

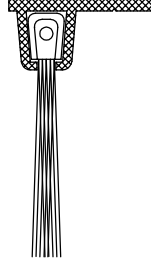

PROFİL KODU	AĞIRLIK (kg/m)
SW-531-00	0.135

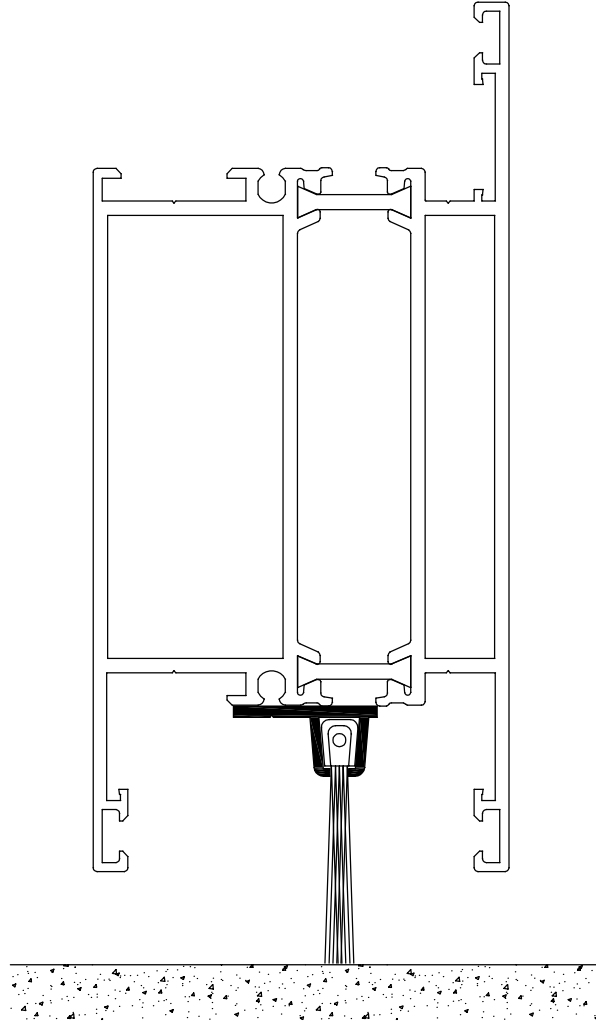

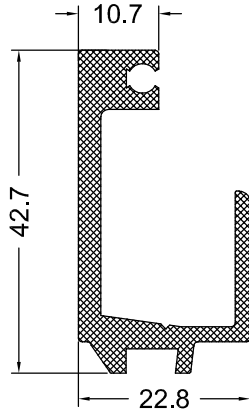

SW ZIVANA PROFİLİ
ÜST

PROFİL KODU	AĞIRLIK (kg/m)
SW-541-00	0.742

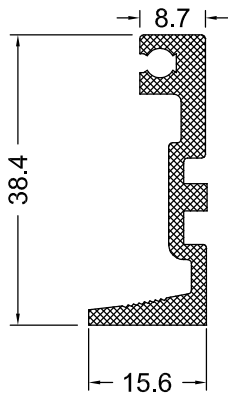

SW ZIVANA PROFİLİ
ALT

PROFİL KODU	AĞIRLIK (kg/m)
SW-542-00	0.499

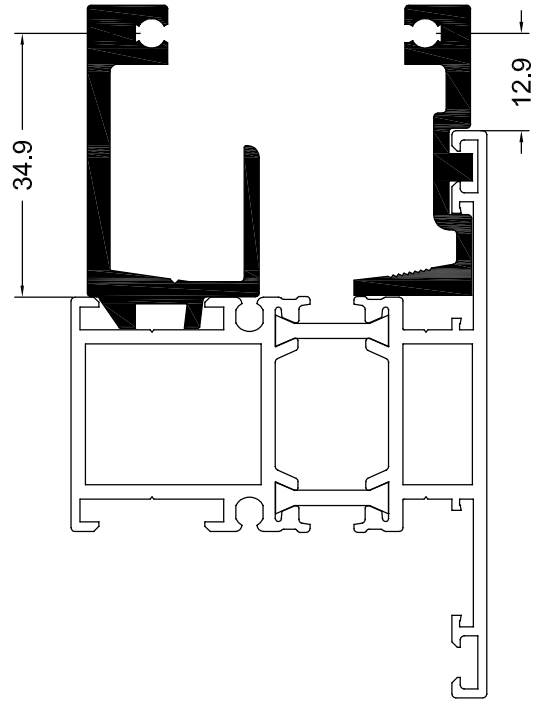

DAMLALIK PROFİLİ

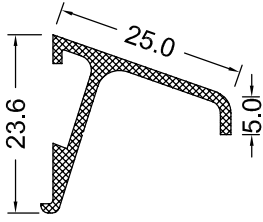

PROFİL KODU	AĞIRLIK (kg/m)
SW-532-00	0.217

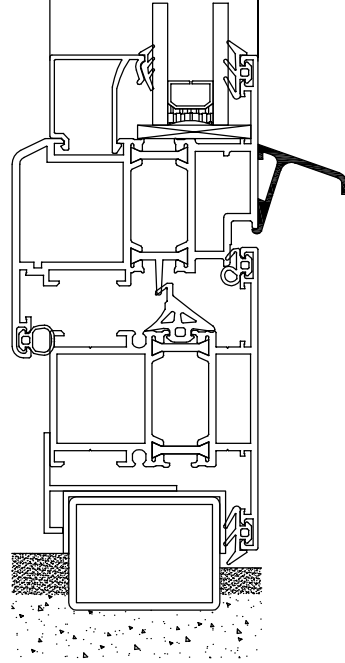

İSPANYOLET TİJ PROFİLİ

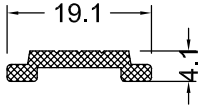

PROFİL KODU	AĞIRLIK (kg/m)
SW-533-00	0.125

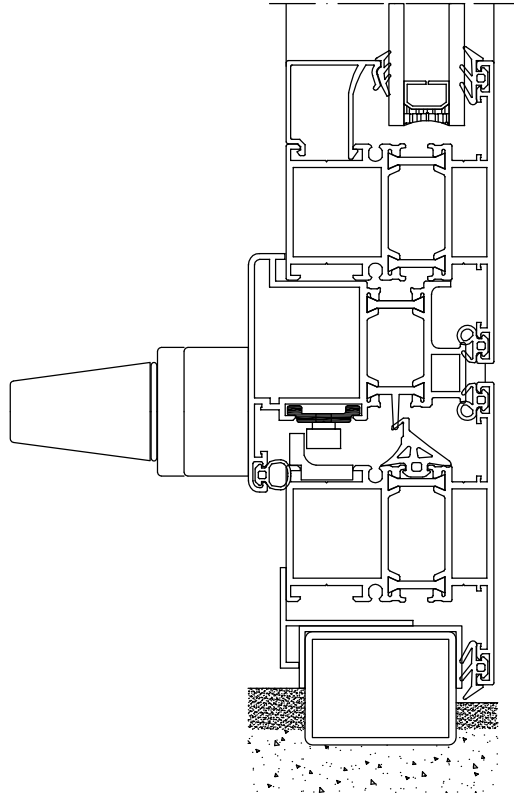

KAPATMA "T" PROFİLLERİ

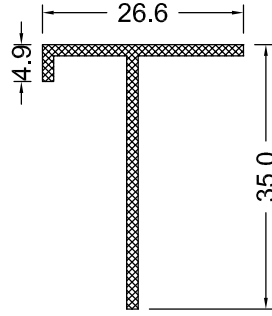

PROFİL KODU	AĞIRLIK (kg/m)
SW-901-15	0.257

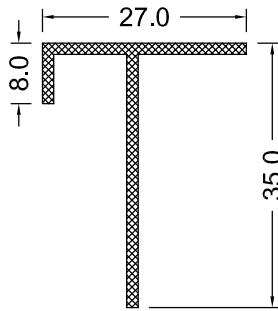

PROFİL KODU	AĞIRLIK (kg/m)
SW-902-15	0.271

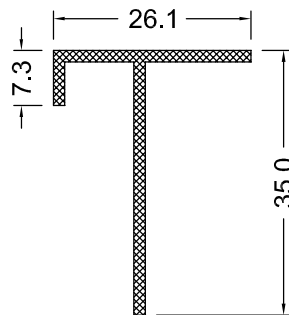

PROFİL KODU	AĞIRLIK (kg/m)
SW-903-15	0.265

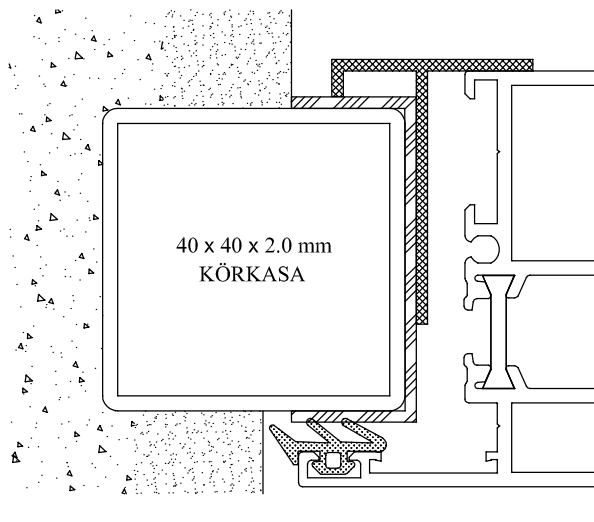
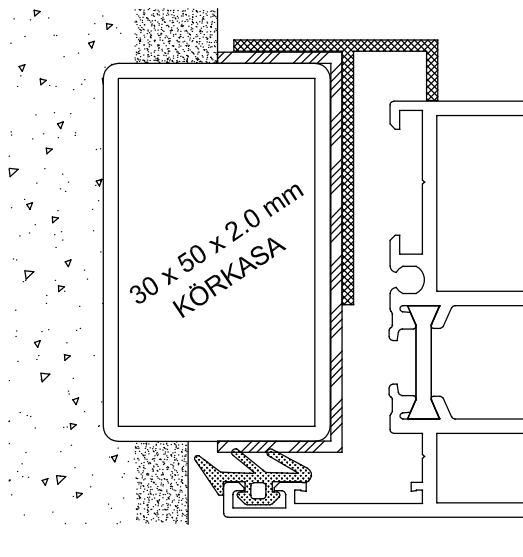
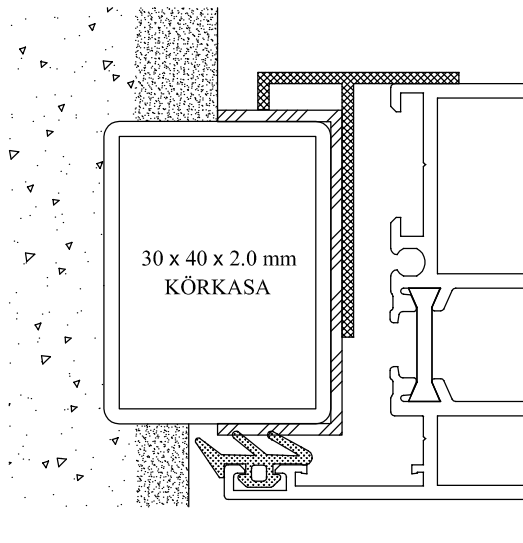

KAPATMA ÇİTALARI

BRÜT CAM BOŞLUKLARI

SW-441-12

0.341 Kg/m

SW-441-15

0.420 Kg/m

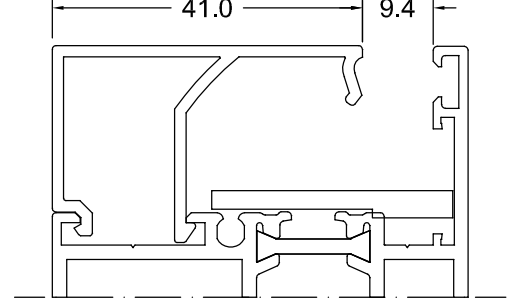
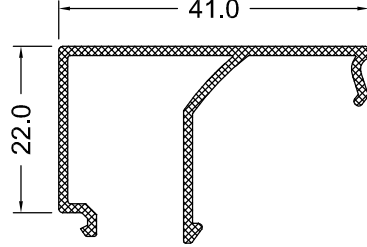

4 mm ve 6 mm cam

SW-439-12

0.336 Kg/m

SW-439-15

0.412 Kg/m

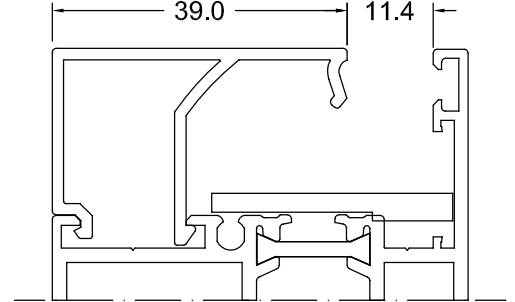
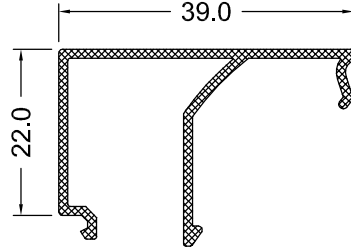

4 mm ve 6 mm cam

SW-437-12

0.328 Kg/m

SW-437-15

0.404 Kg/m

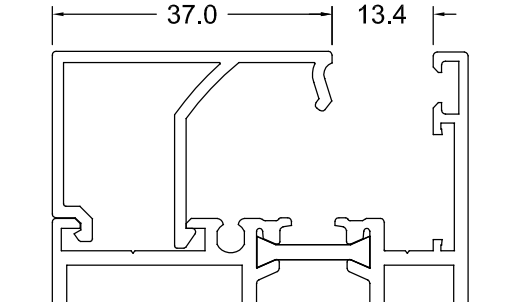
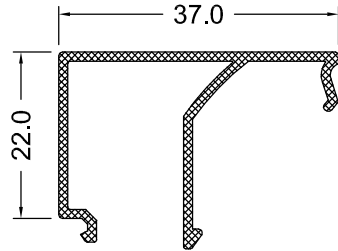

8 mm cam

SW-435-12

0.322 Kg/m

SW-435-15

0.396 Kg/m

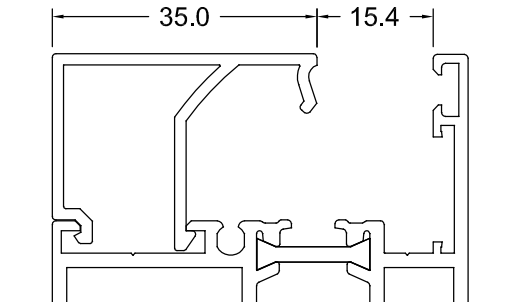
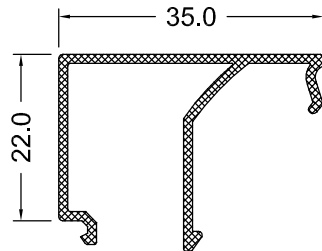

10 mm cam ve tahta lambiri

KAPATMA ÇİTALARI

BRÜT CAM BOŞLUKLARI

SW-433-12

0.314 Kg/m

SW-433-15

0.387 Kg/m

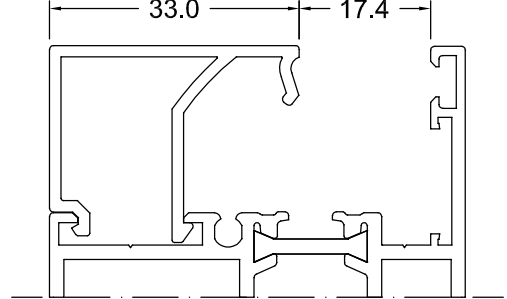
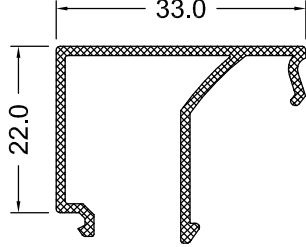

6 + 6 mm lamine cam

SW-431-12

0.309 Kg/m

SW-431-15

0.379 Kg/m

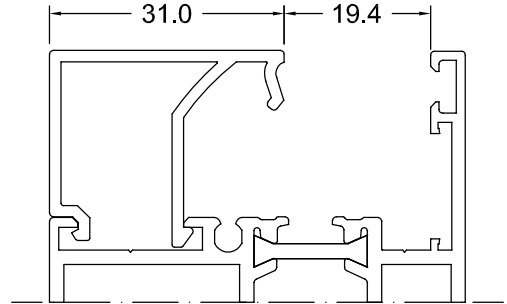
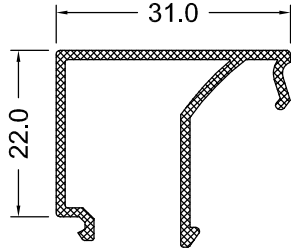

SW-429-12

0.303 Kg/m

SW-429-15

0.371 Kg/m

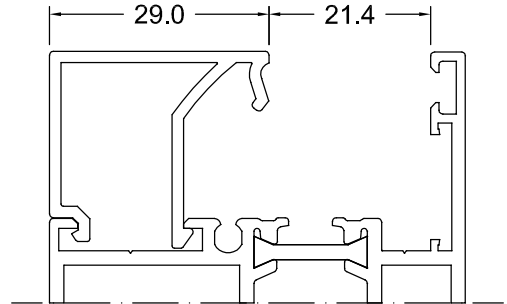
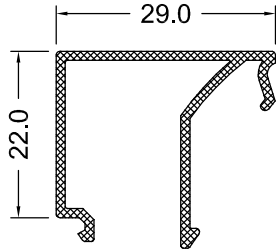

SW-427-12

0.295 Kg/m

SW-427-15

0.357 Kg/m

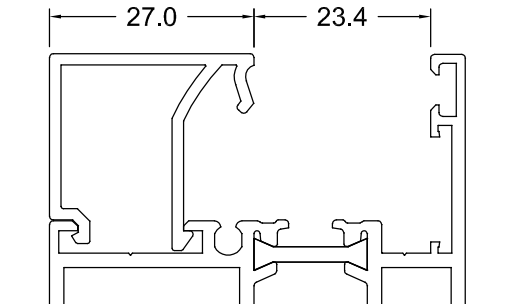
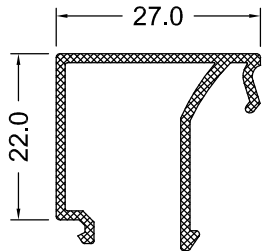

KAPATMA ÇİTALARI

BRÜT CAM BOŞLUKLARI

SW-425-12

0.290 Kg/m

SW-425-15

0.347 Kg/m

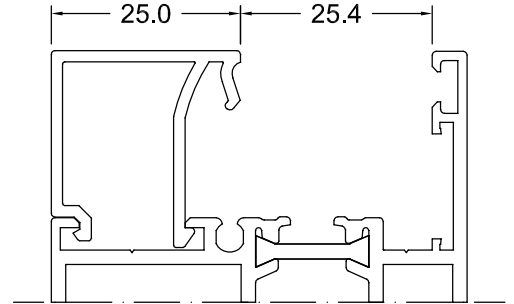
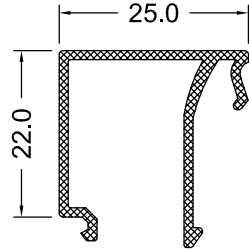

SW-423-12

0.279 Kg/m

SW-423-15

0.341 Kg/m

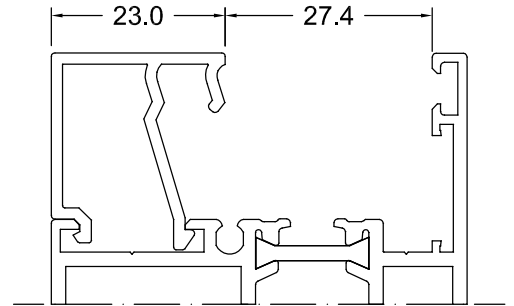
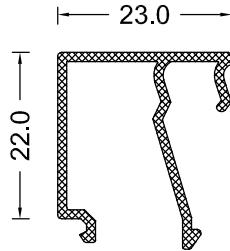

SW-421-12

0.271 Kg/m

SW-421-15

0.333 Kg/m

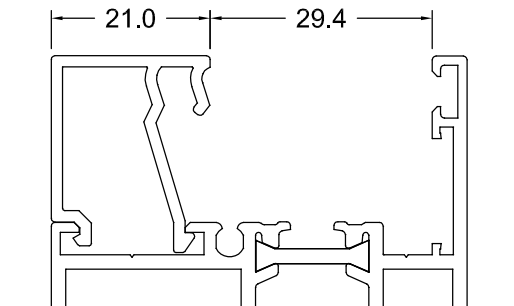
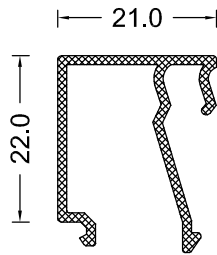

SW-419-12

0.274 Kg/m

SW-419-15

0.336 Kg/m

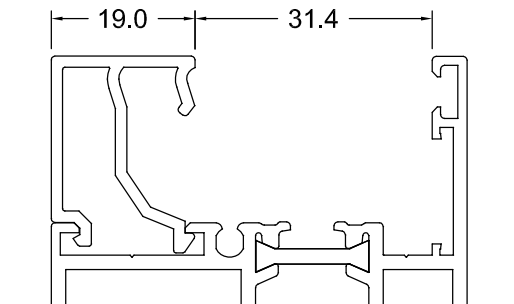
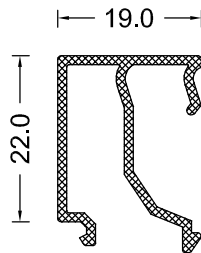

KAPATMA ÇİTALARI

BRÜT CAM BOŞLUKLARI

SW-417-12

0.268 Kg/m

SW-417-15

0.328 Kg/m

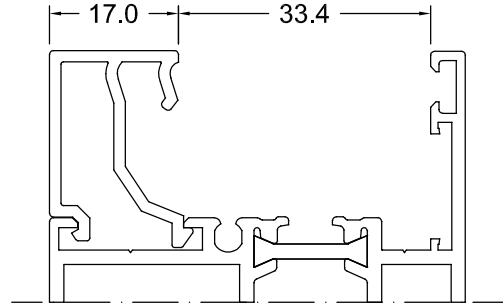
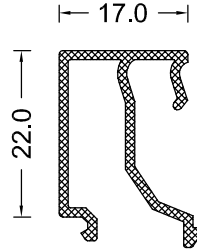

SW-415-12

0.236 Kg/m

SW-415-15

0.290 Kg/m

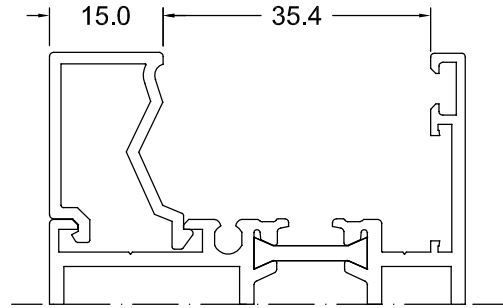
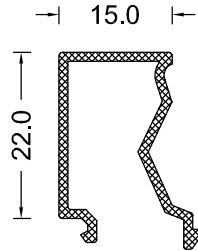

SW-413-12

0.230 Kg/m

SW-413-15

0.282 Kg/m

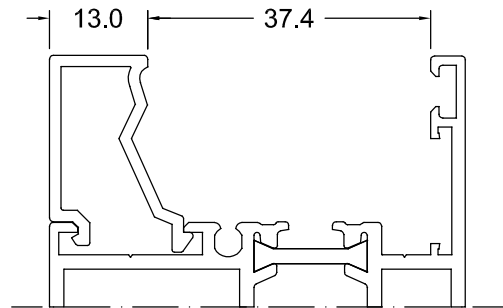
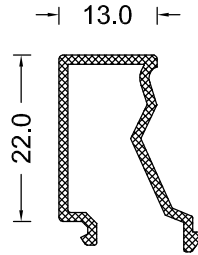

SW-410-12

0.225 Kg/m

SW-410-15

0.276 Kg/m

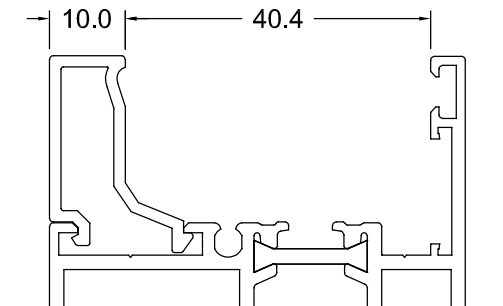
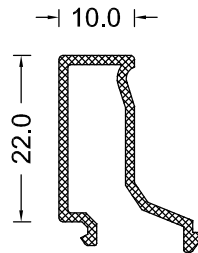

KAPATMA ÇİTASI

PROFİL KODU	AĞIRLIK (kg/m)
SW-405-14	0.198

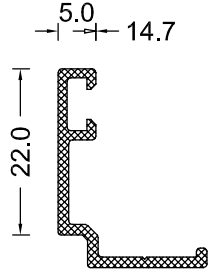

BRÜT CAM BOŞLUK

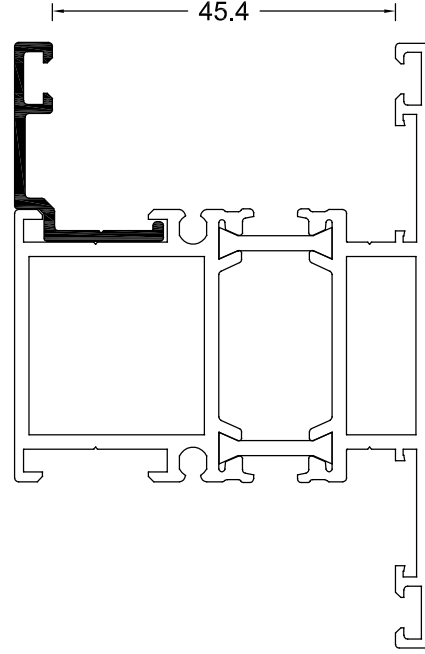

KİLİT KARŞILIĞI

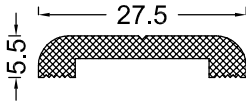

PROFİL KODU	AĞIRLIK (kg/m)
SW-548-00	0.268

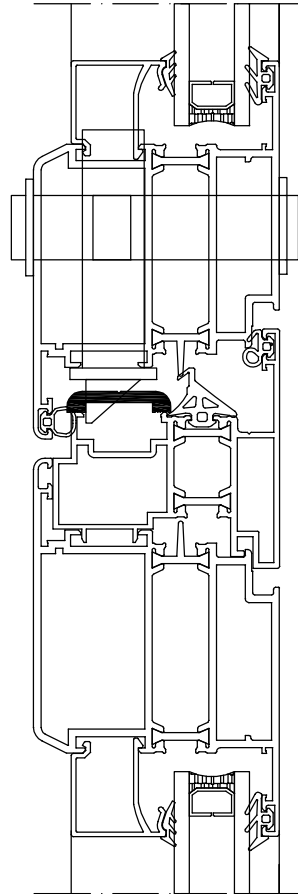

NET CAM BOŞLUKLARI

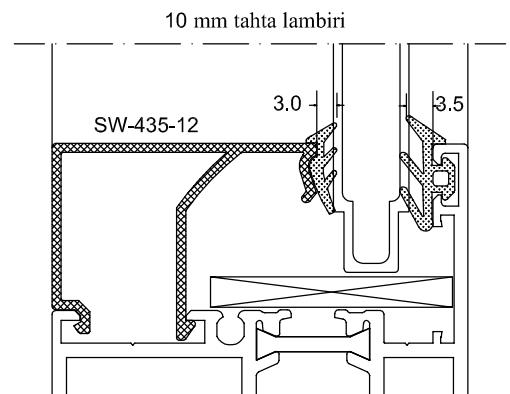
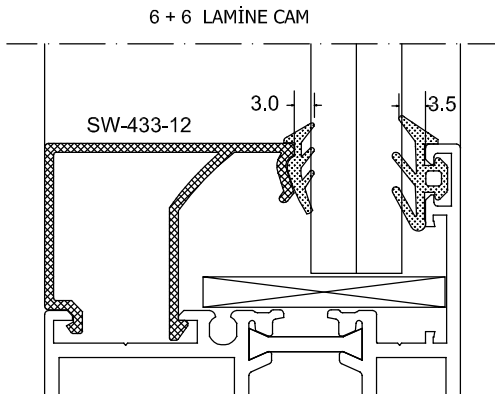
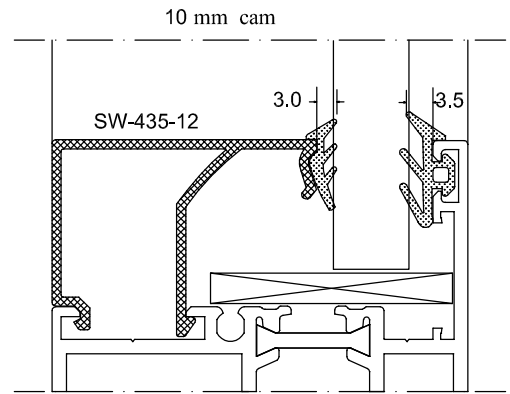
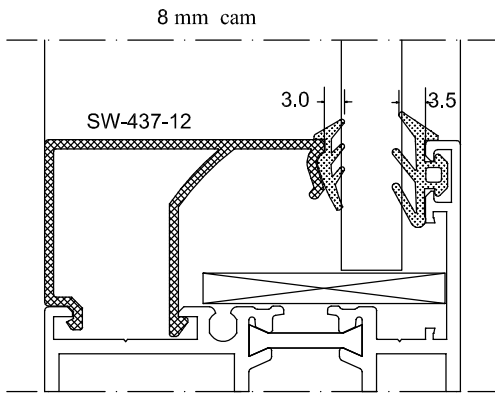
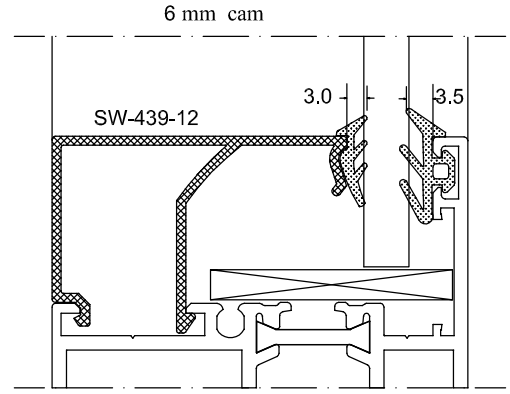
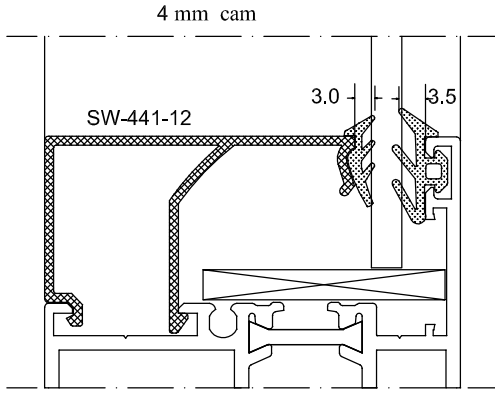

NET CAM BOŞLUKLARI

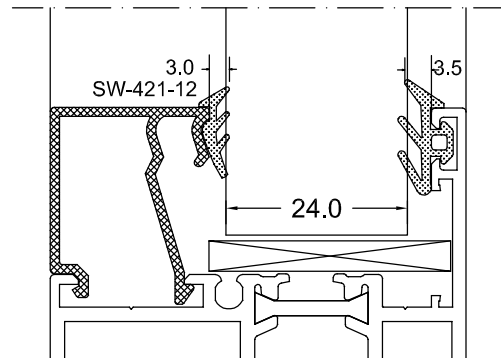
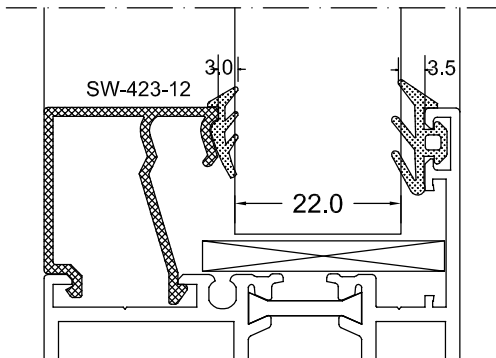
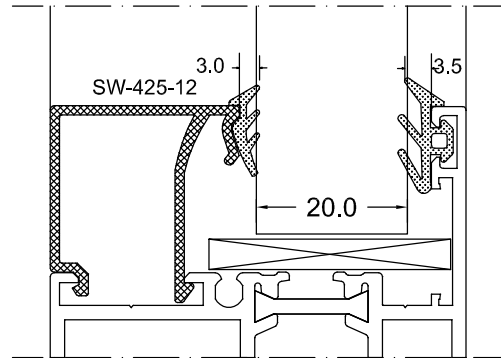
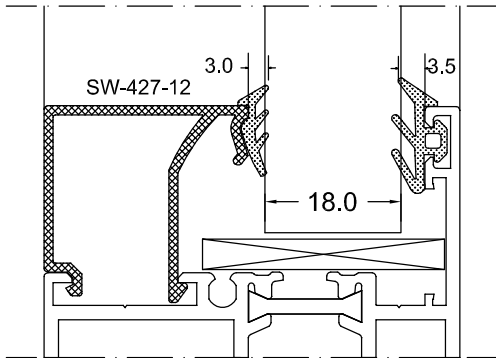
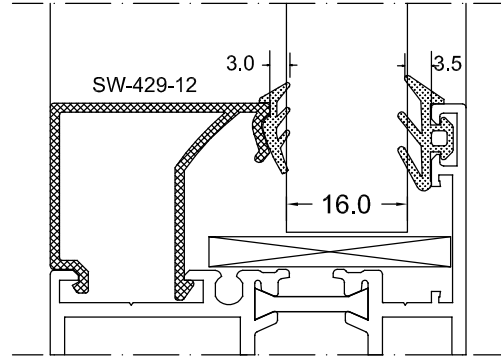
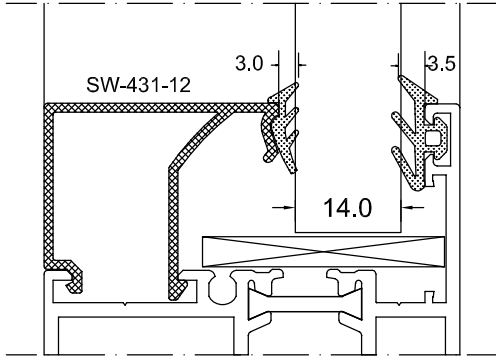

NET CAM BOŞLUKLARI

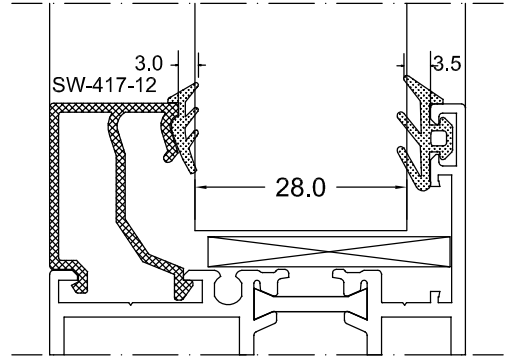
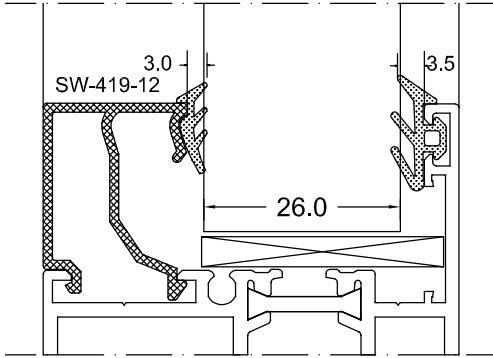

MICRO JALUZI

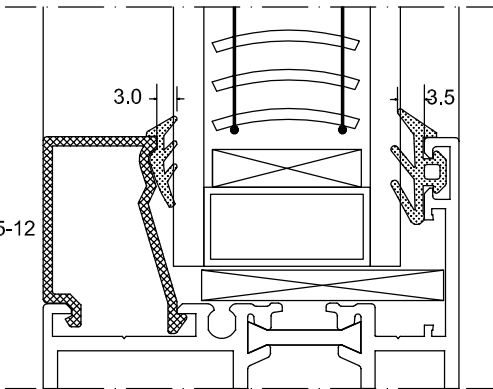

30 mm PANEL

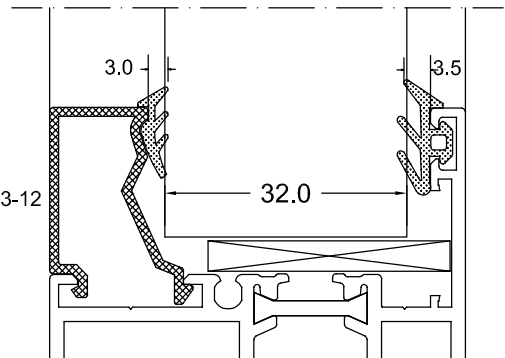
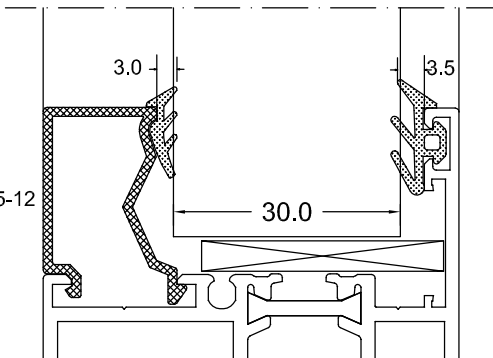
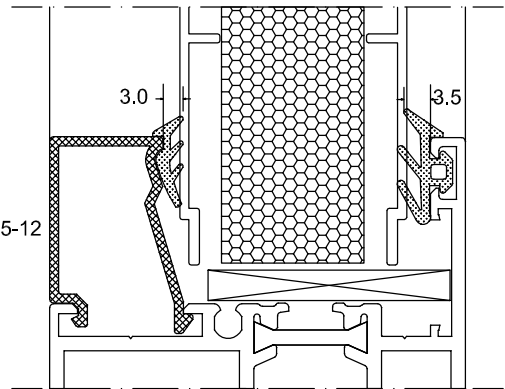



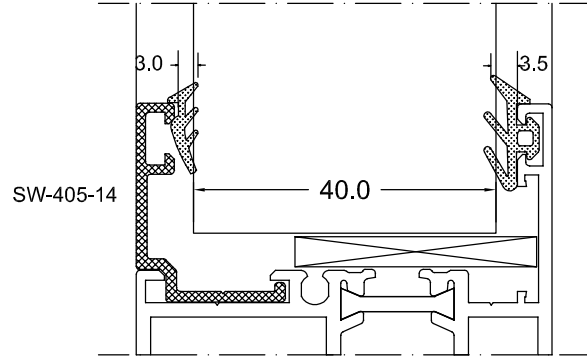
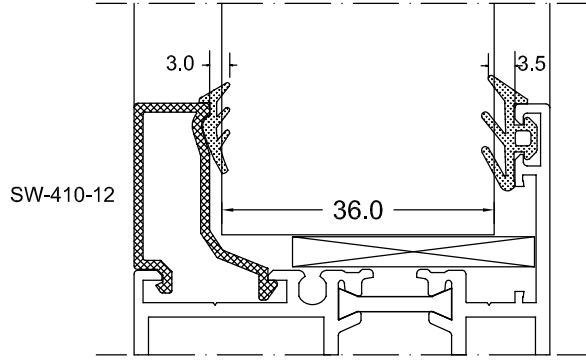



NET CAM BOŞLUKLARI

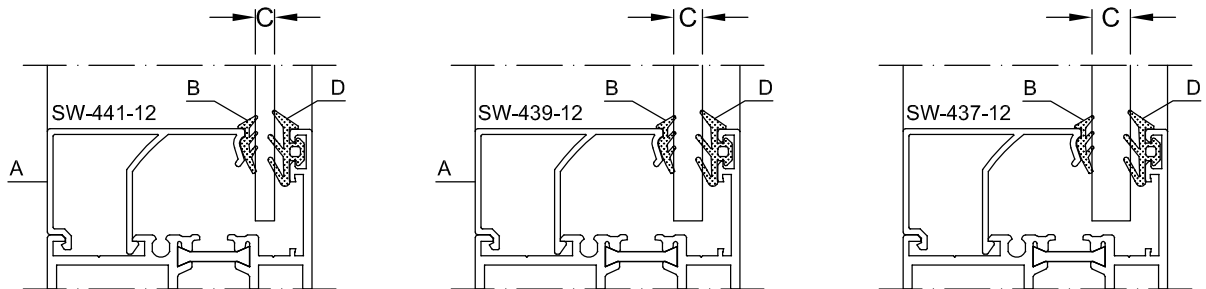
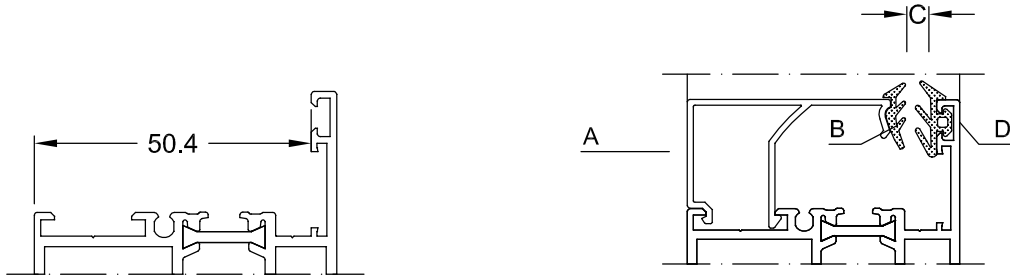

CAM KALINLIĞINA GÖRE FİTİL TAYİNİ

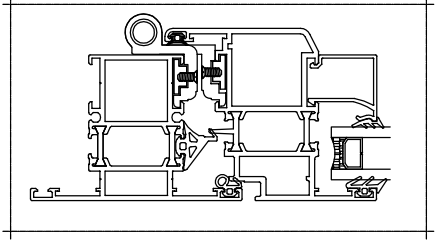
A CAM ÇITASI	B İÇ CAM FİTİLİ	C CAM KALINLIĞI	D DIŞ CAM FİTİLİ	TOPLAM BOŞLUK
SW-441-12	EPD 05	4 mm	EPD 04	50.4 mm
SW-439-12	EPD 05	6 mm	EPD 04	
SW-437-12	EPD 05	8 mm	EPD 04	
SW-435-12	EPD 05	10 mm	EPD 04	
SW-433-12	EPD 05	12 mm	EPD 04	
SW-431-12	EPD 05	14 mm	EPD 04	
SW-429-12	EPD 05	16 mm	EPD 04	
SW-427-12	EPD 05	18 mm	EPD 04	
SW-425-12	EPD 05	20 mm	EPD 04	
SW-423-12	EPD 05	22 mm	EPD 04	
SW-421-12	EPD 05	24 mm	EPD 04	
SW-419-12	EPD 05	26 mm	EPD 04	
SW-417-12	EPD 05	28 mm	EPD 0 thickness	
SW-415-12	EPD 05	30 mm	EPD 04	
SW-413-12	EPD 05	32 mm	EPD 04	
SW-410-12	EPD 05	36 mm	EPD 04	
SW-405-14	EPD 05	40 mm	EPD 04	

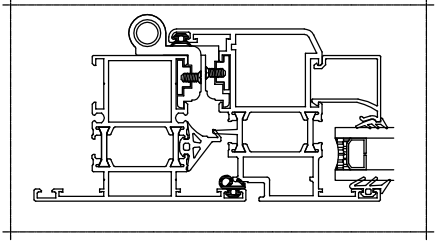
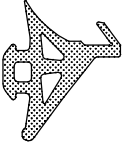
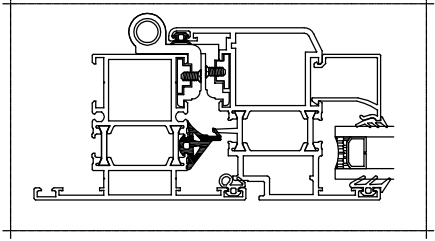
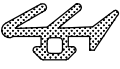
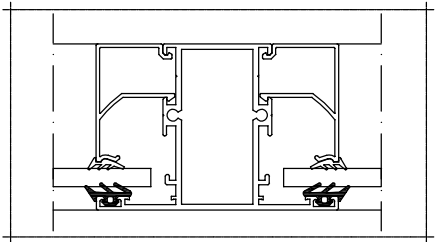

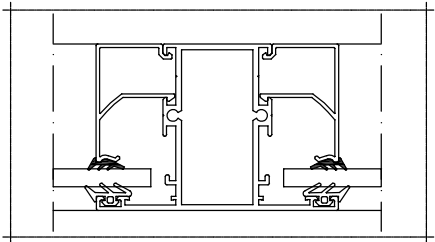
Aksesuar Kodu	Aksesuar Resmi	Teslimat Şekli	Montaj Çizimi
<u>EPD 01</u>		1 KOLİ 380mt/13Kg 34gr/m	
<u>EPD 02</u>		1 KOLİ 350mt/15Kg 42gr/m	
<u>EPD 03</u>		1 KOLİ 120mt/15Kg 125gr/m	
<u>EPD 04</u>		1 KOLİ 270mt/16Kg 59gr/m	
<u>EPD 05</u>		1 KOLİ 340mt/15Kg 44gr/m	

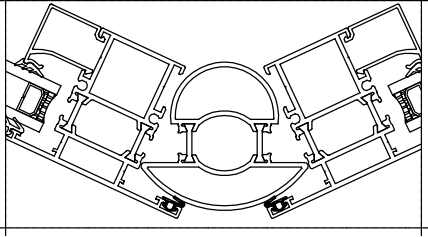
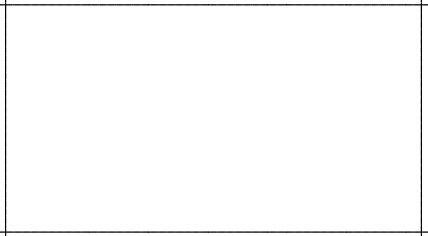
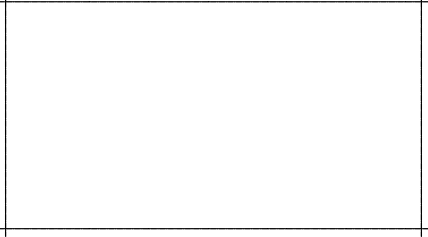
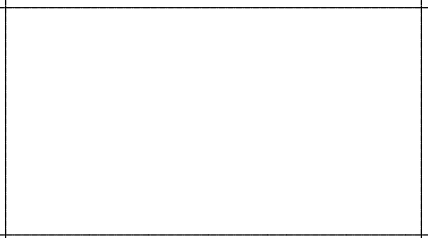
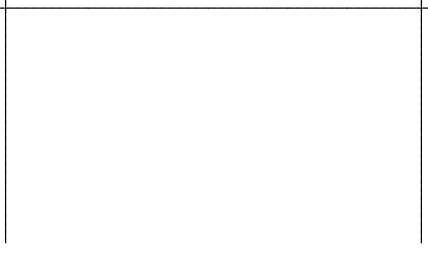
Aksesuar Kodu	Aksesuar Resmi	Teslimat Şekli	Montaj Çizimi
<u>EPC 71</u>		1 KOLİ 260mt/13Kg 50gr/m	
			
			
			
			



ALUFOUR

YALITIMLI DOĞRAMA SİSTEMİ



ALUFOUR

YALITIMLI DOĞRAMA SİSTEMİ

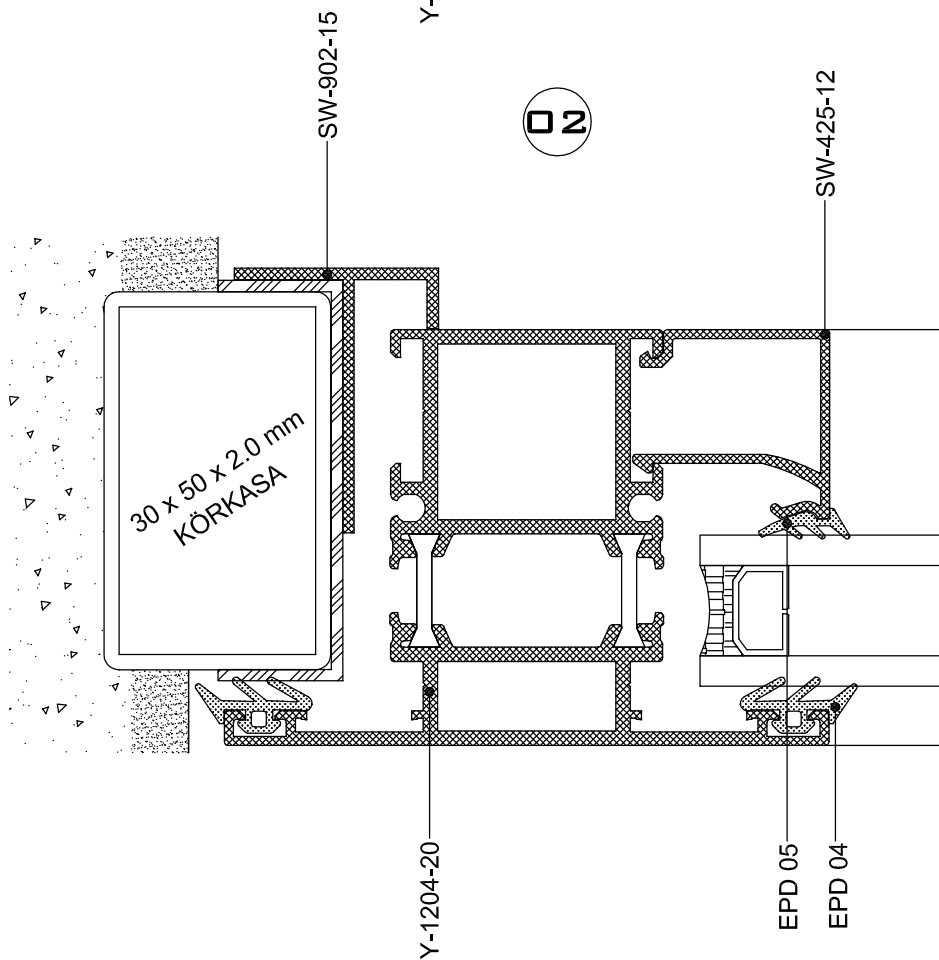
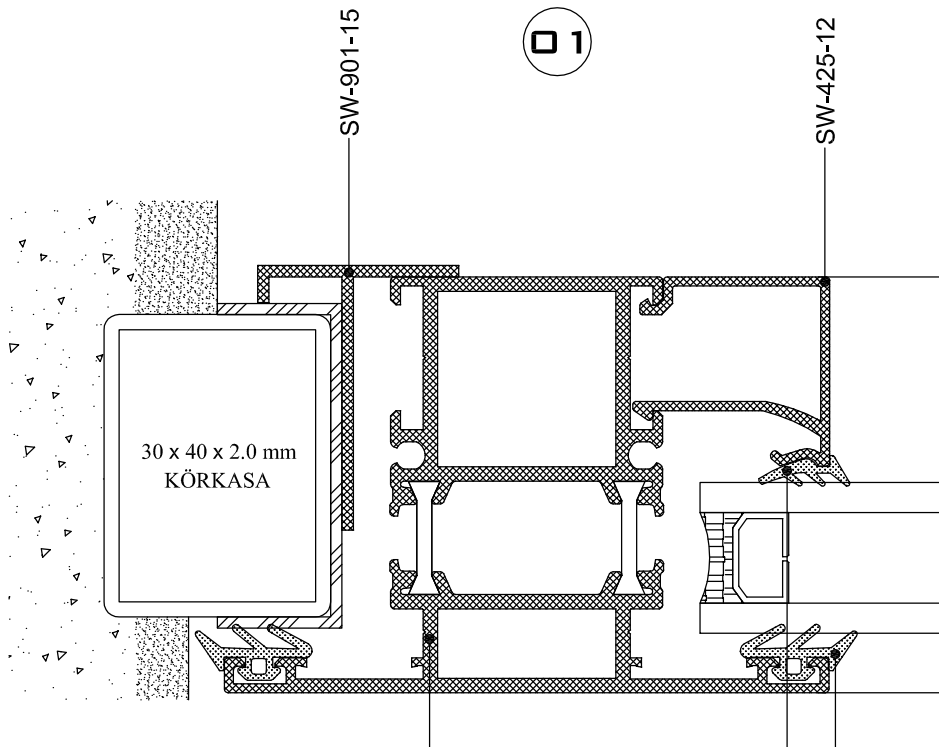

03

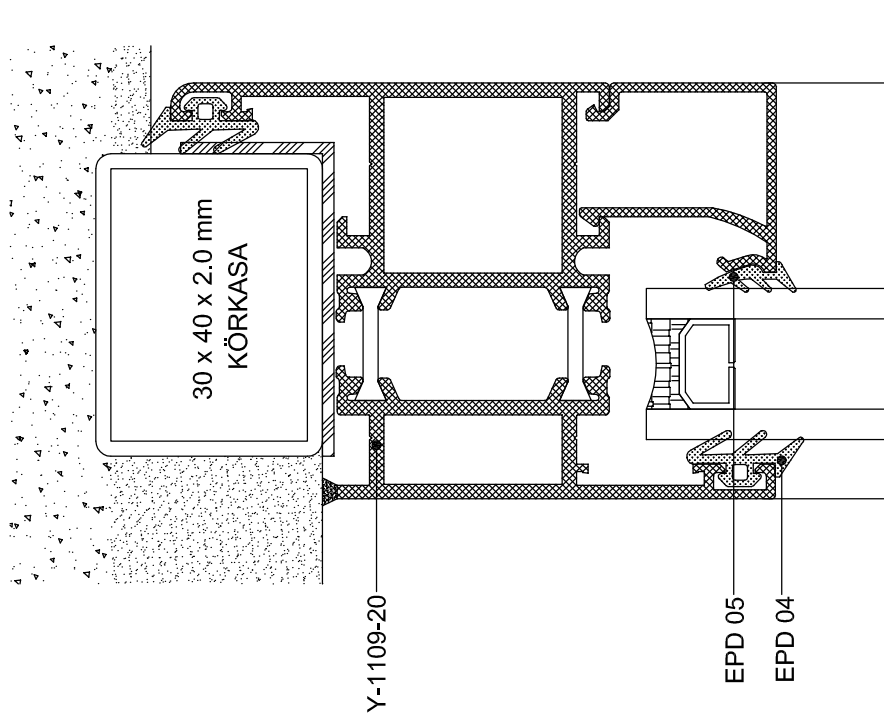

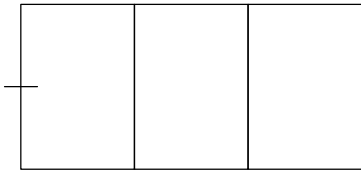

04

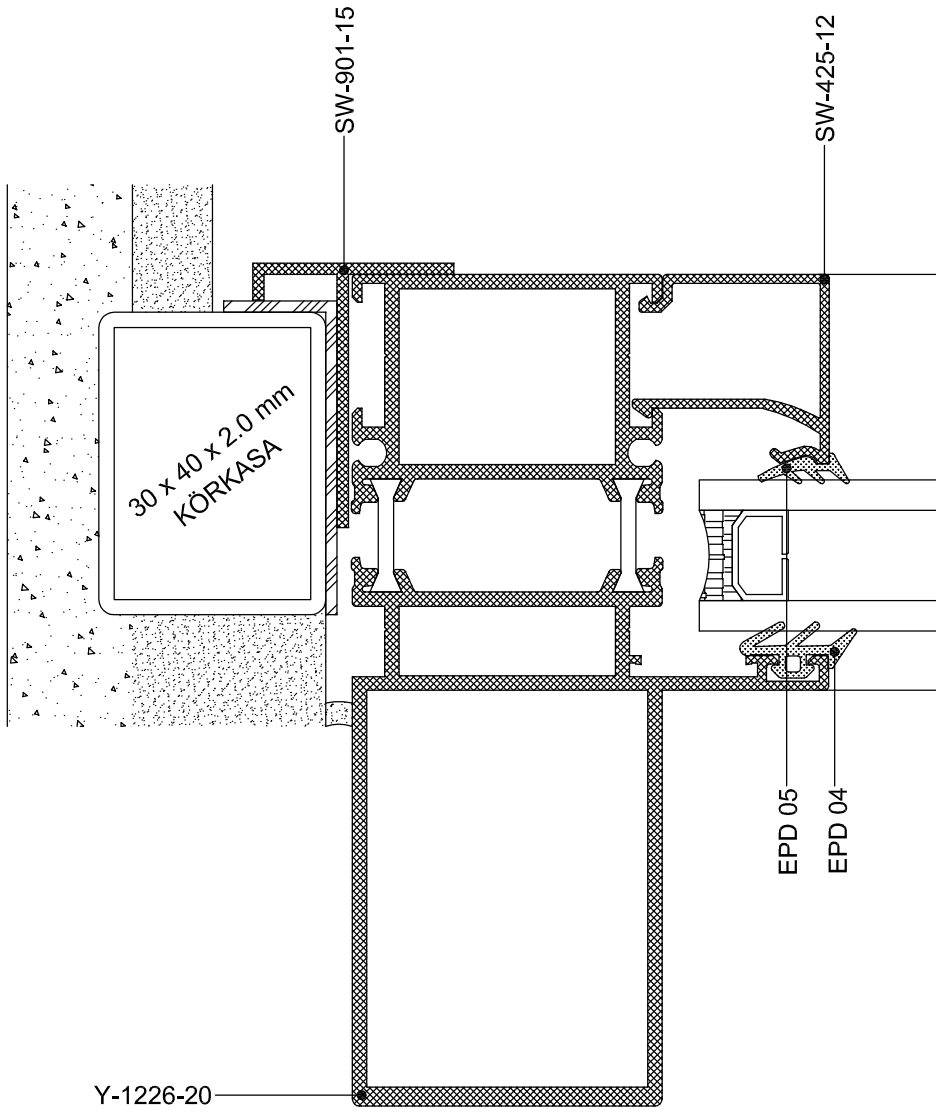

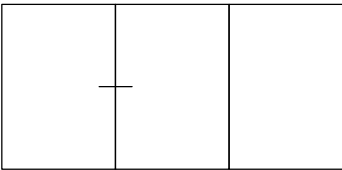

05

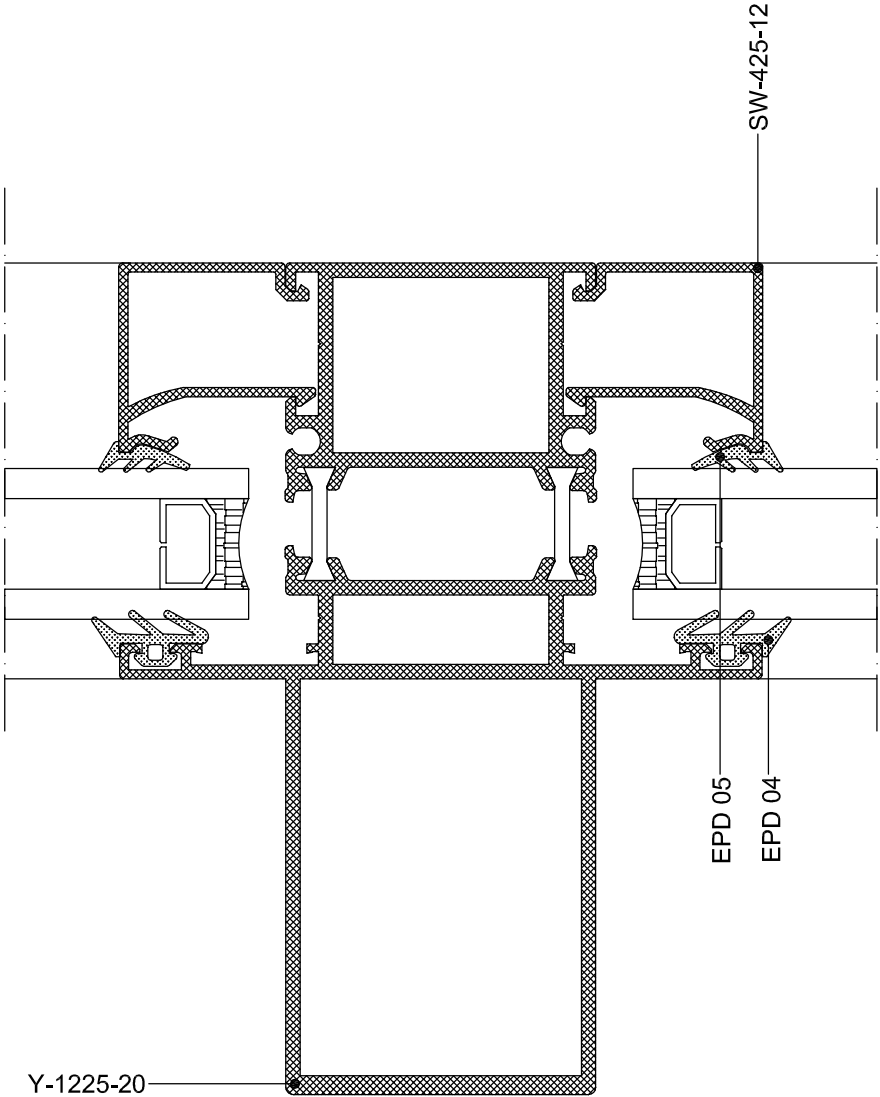

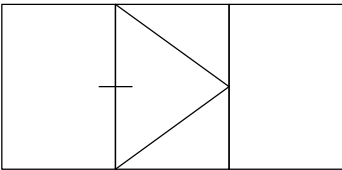

06

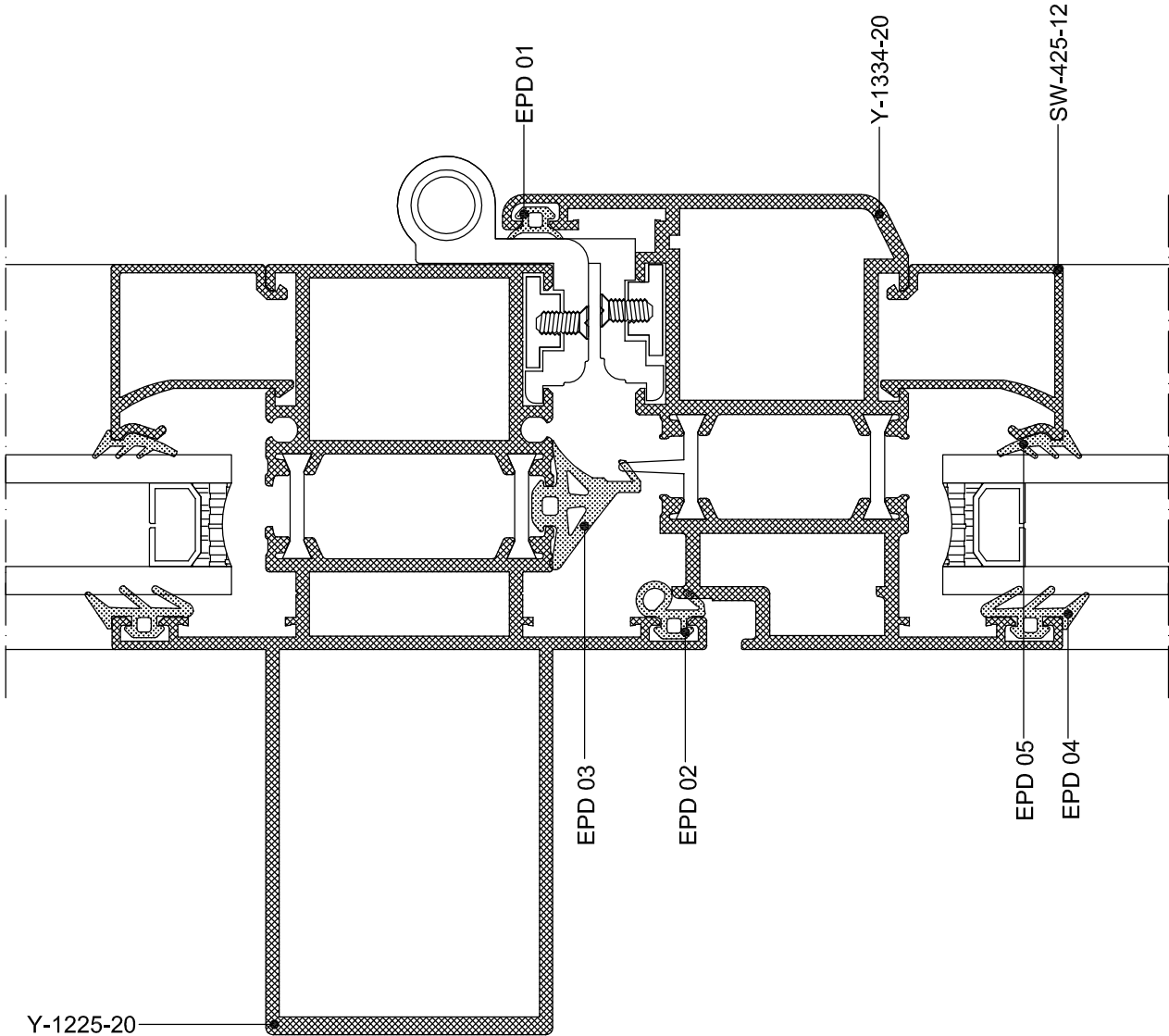

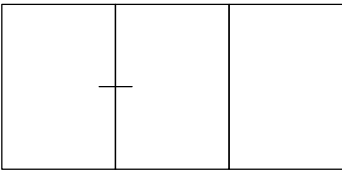

07

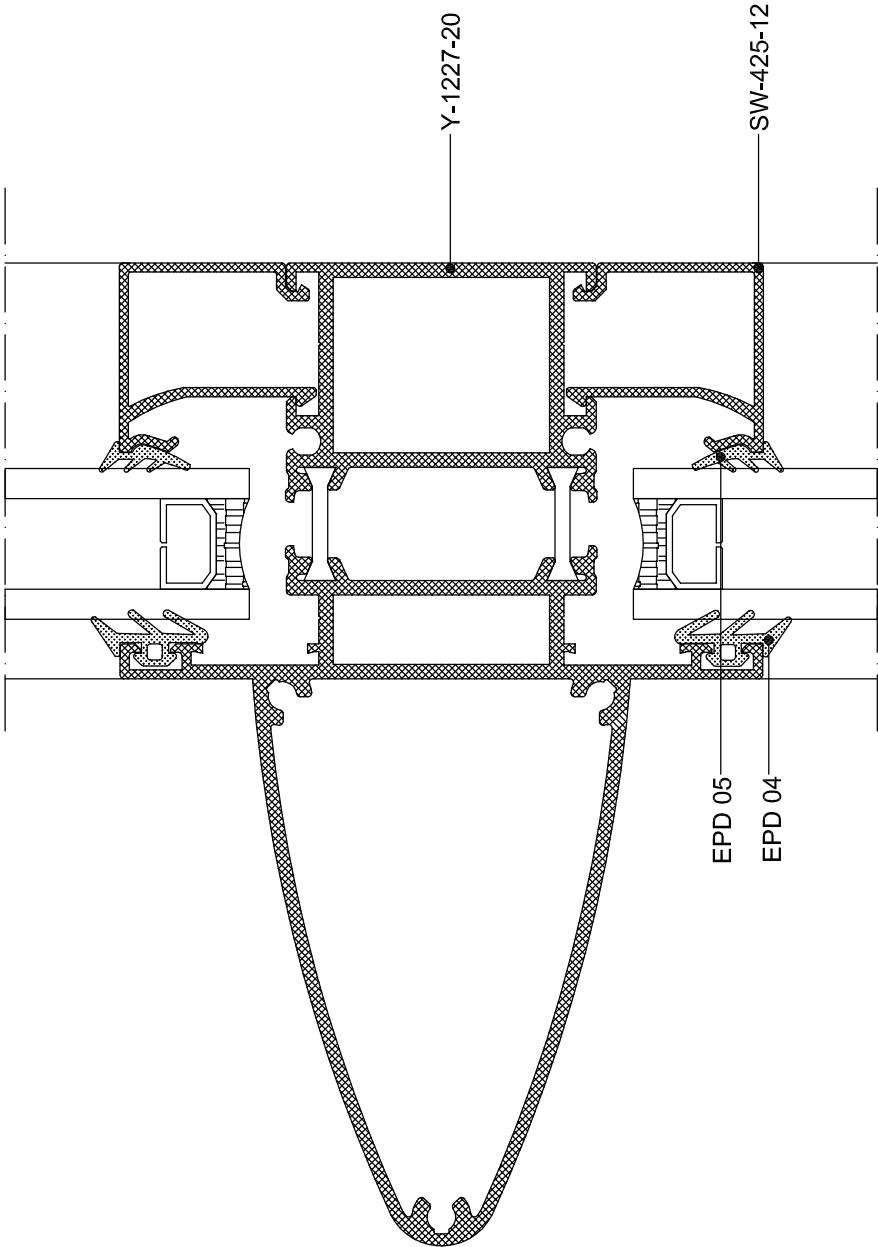

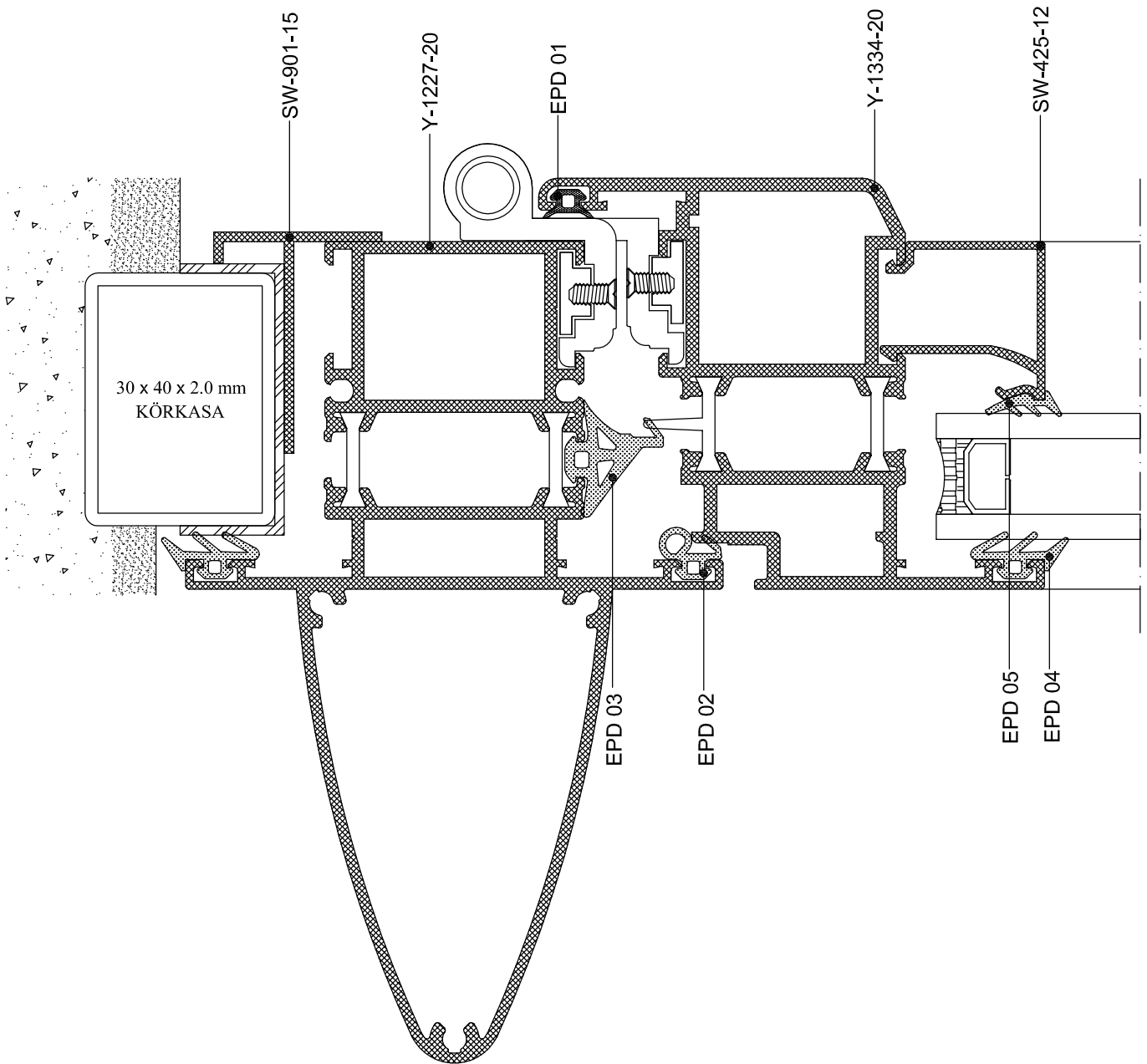
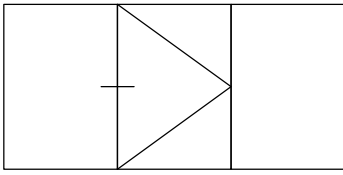

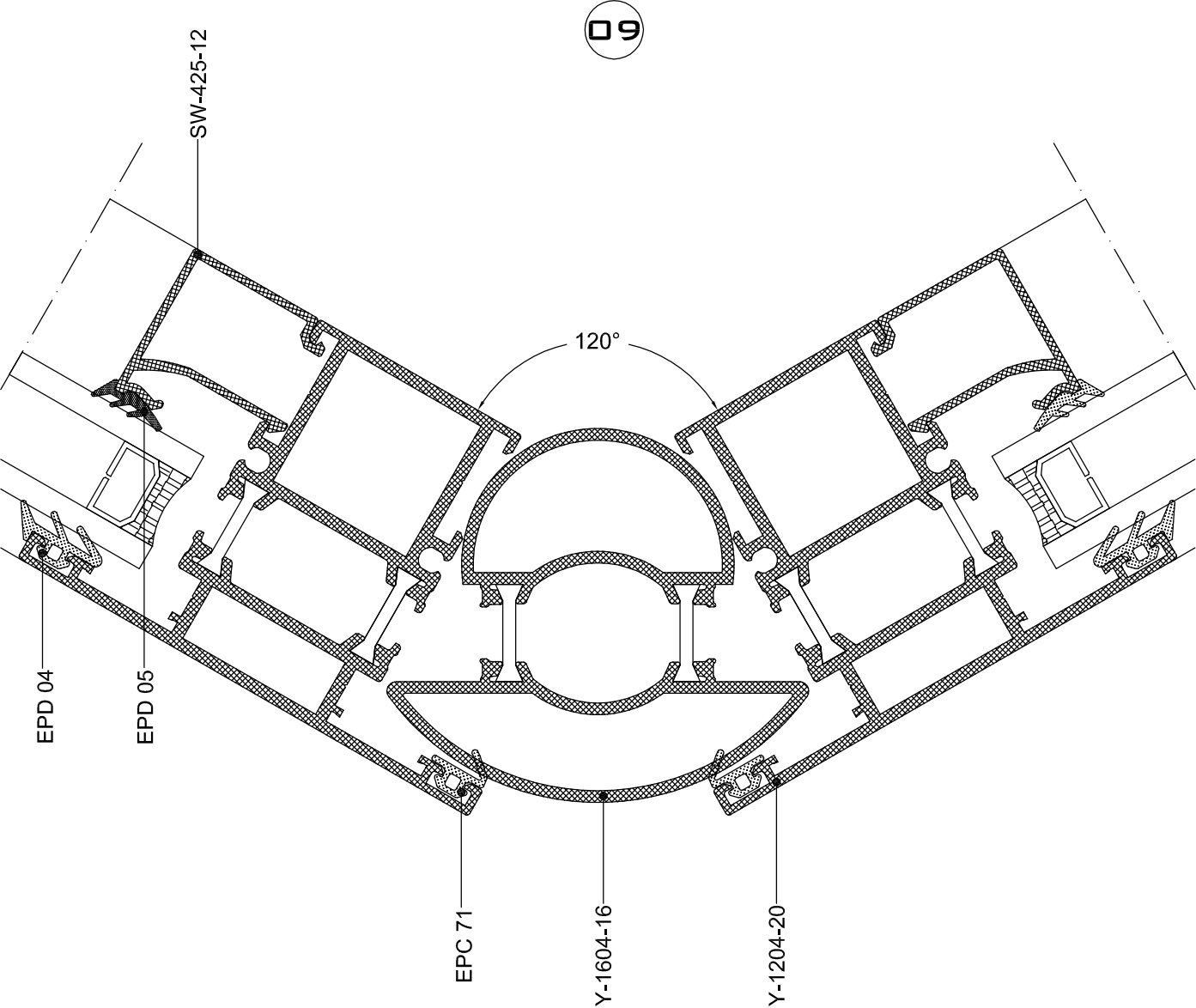

10

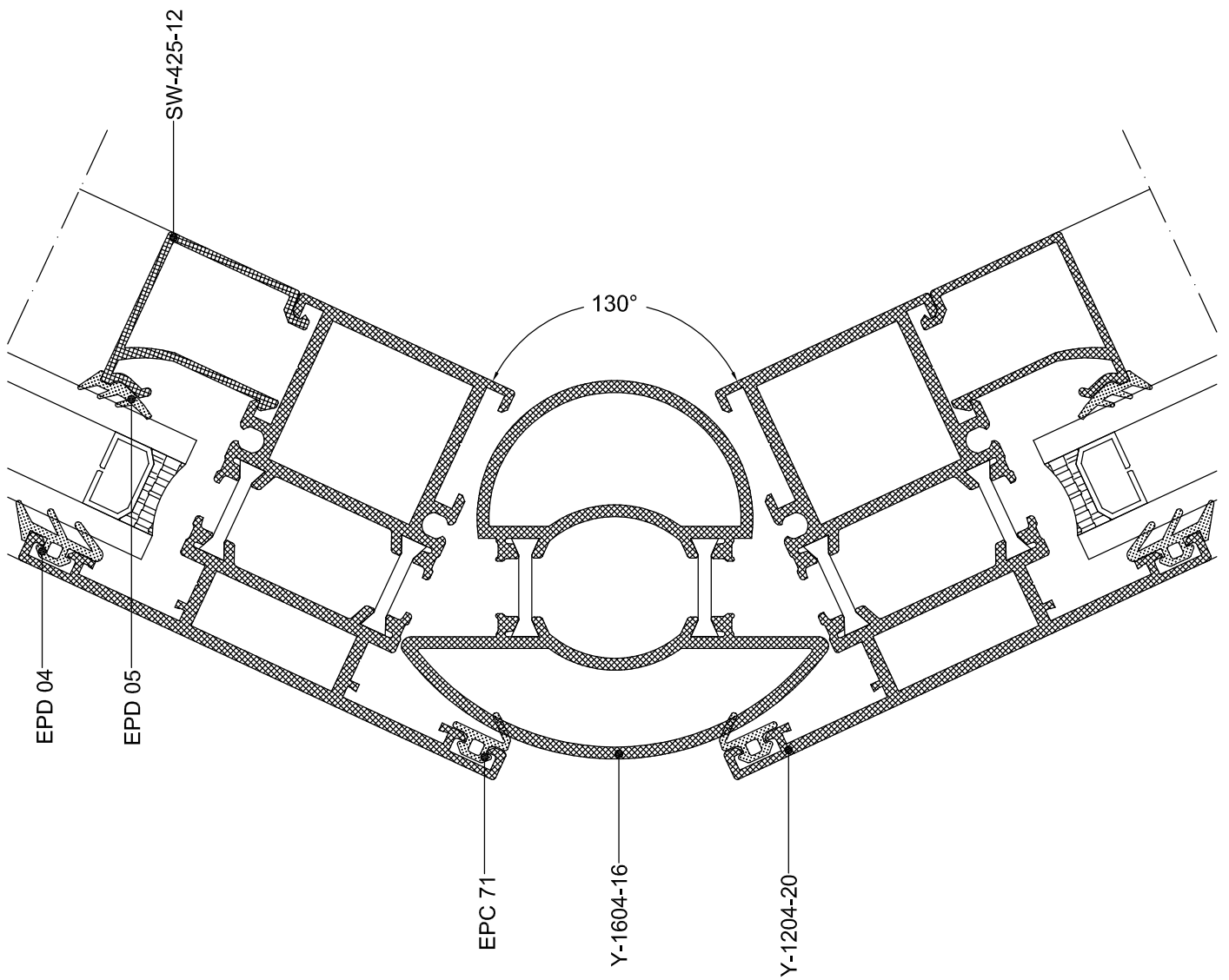

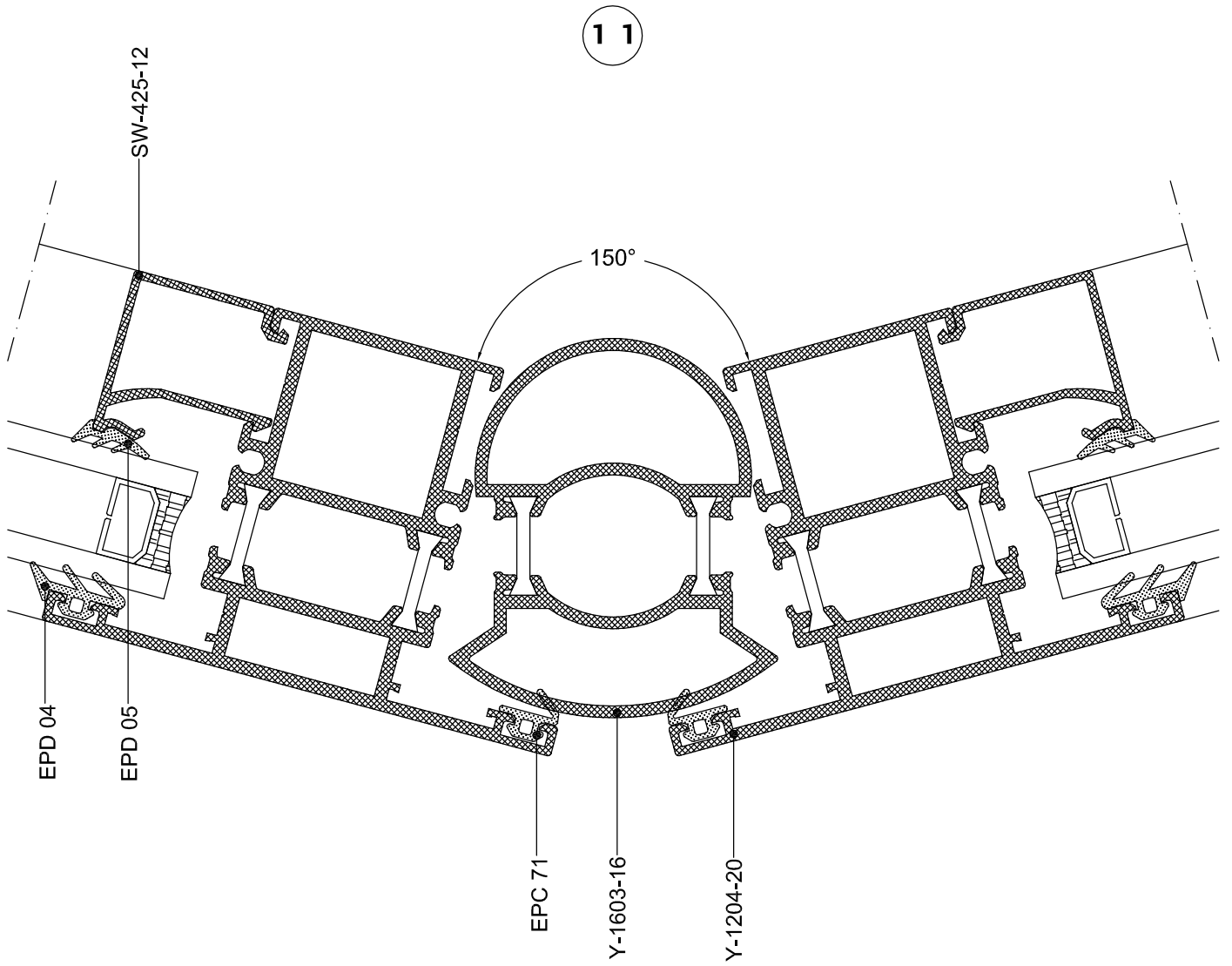

12

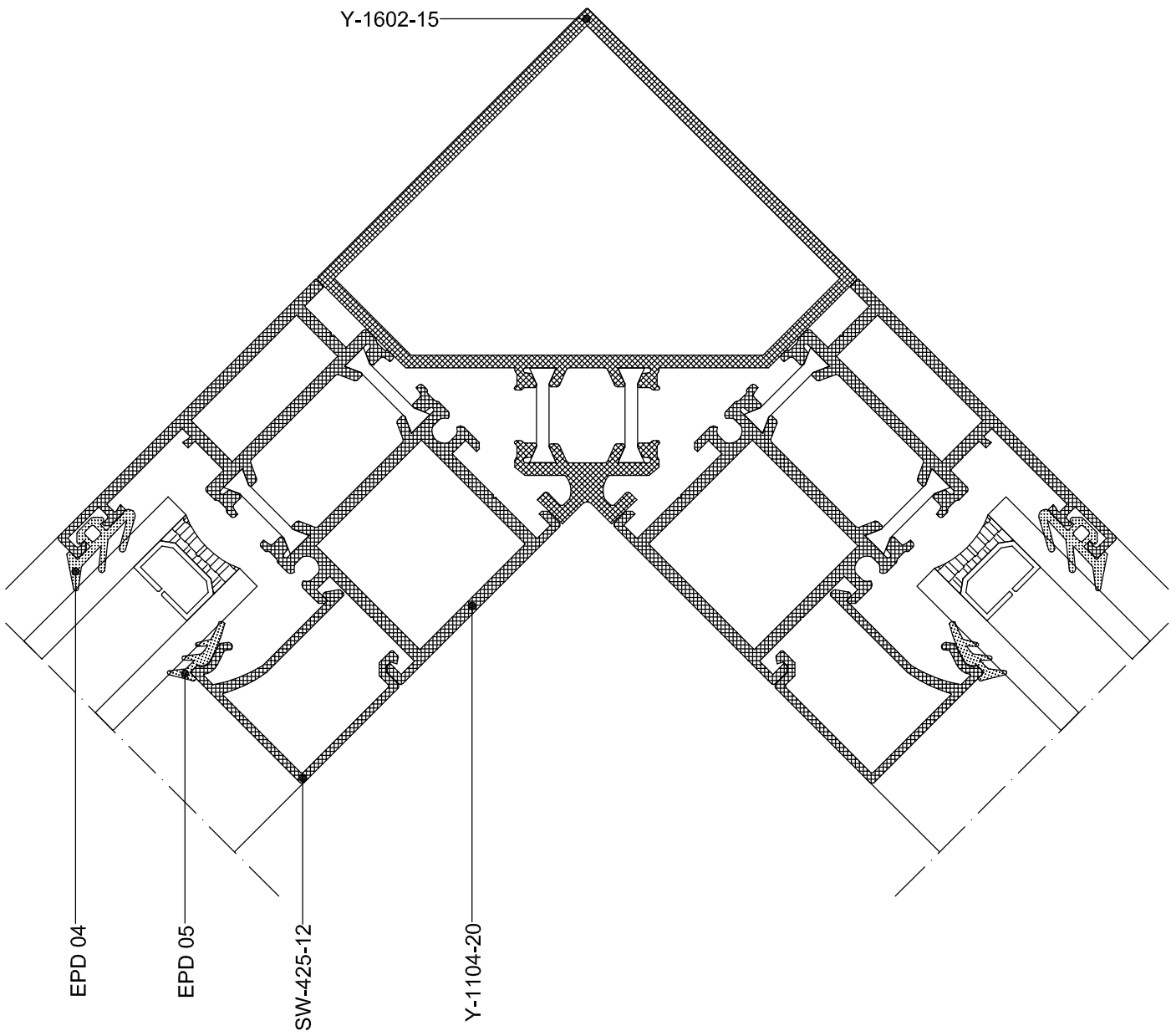

13

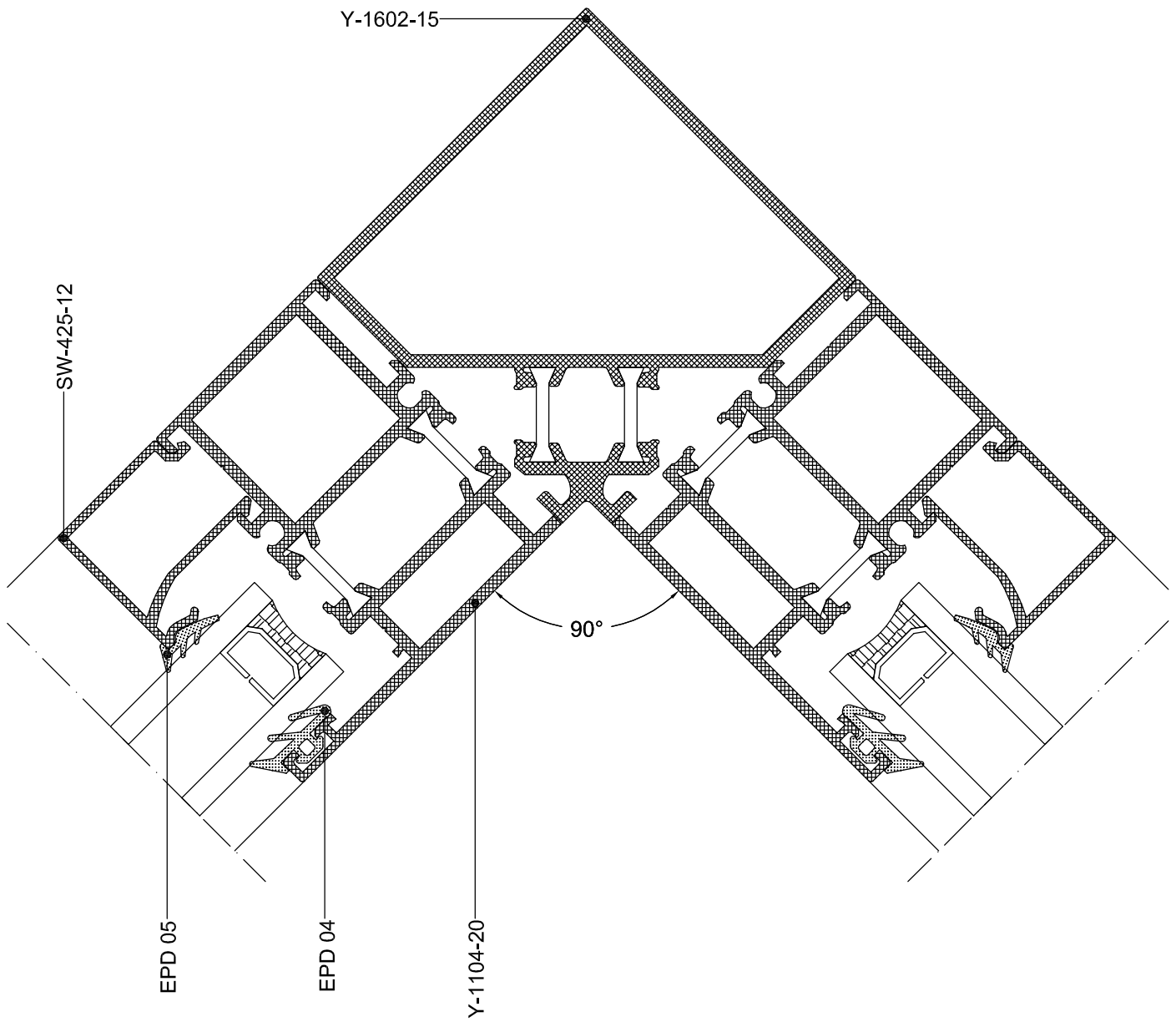

14

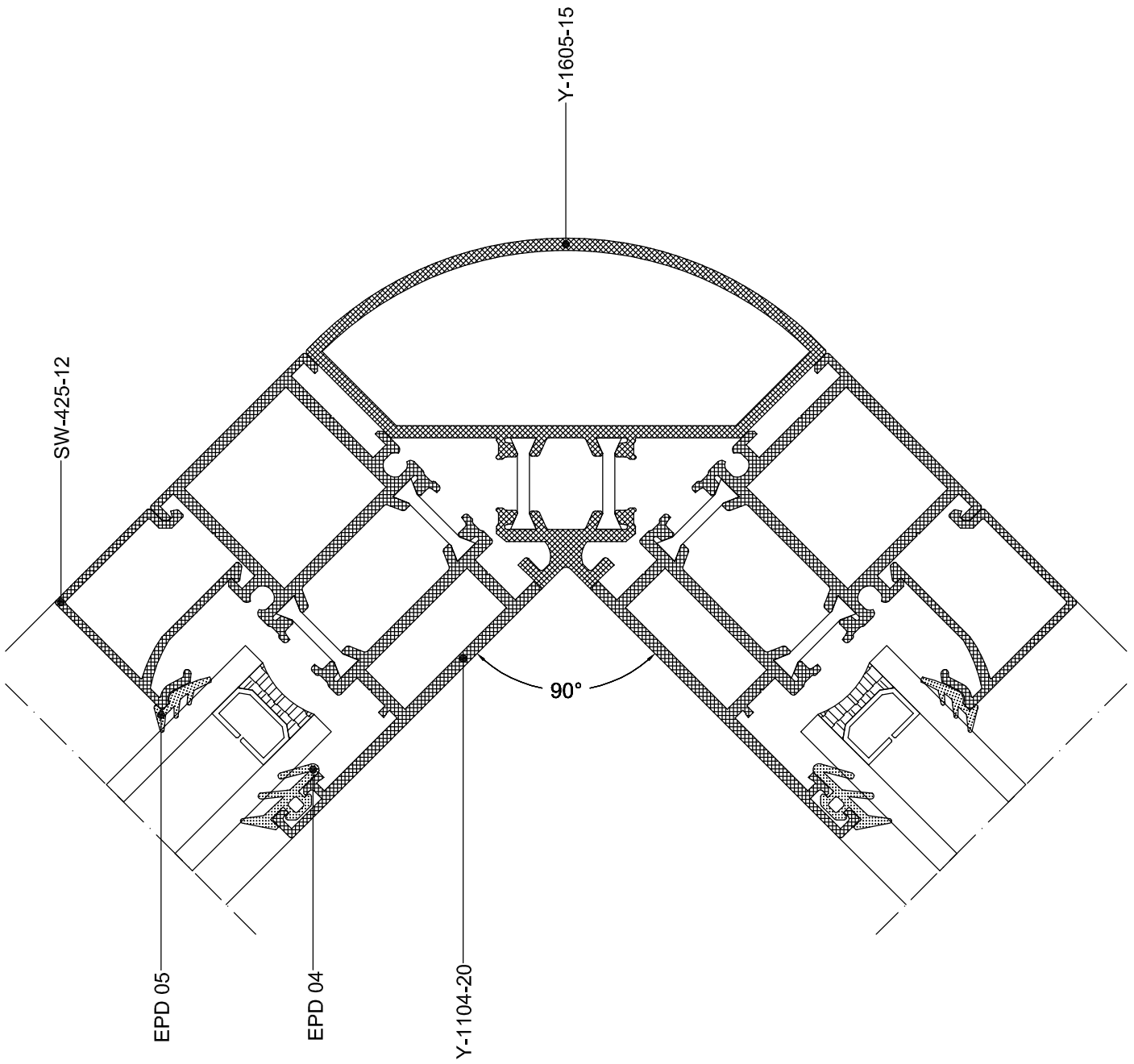

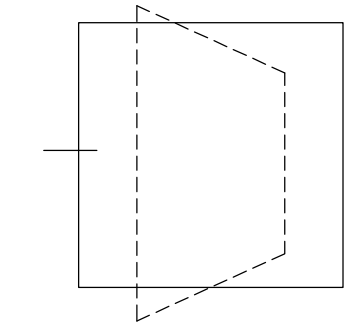

PİVOT PENCERE UYGULAMA DETAYLARI

15

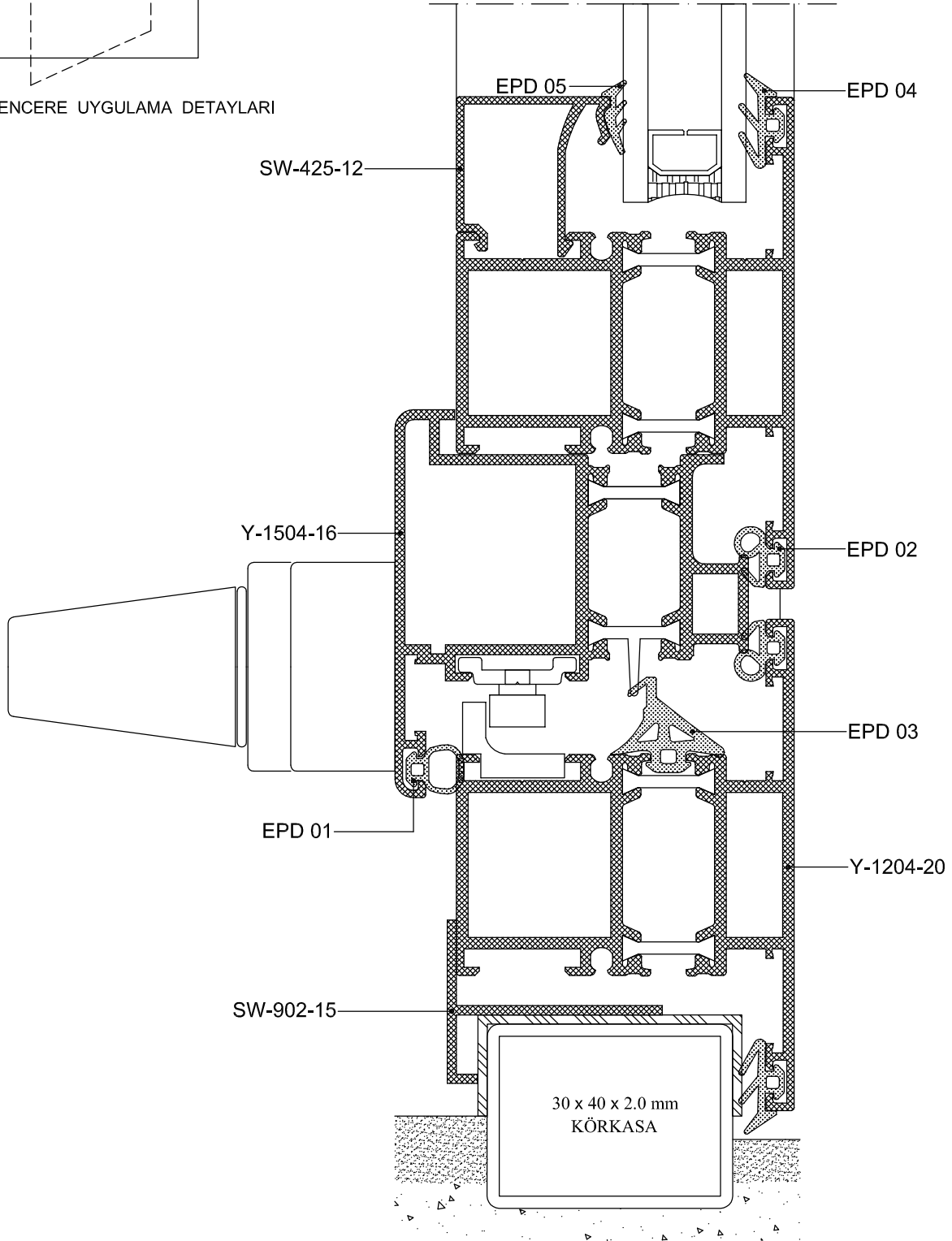

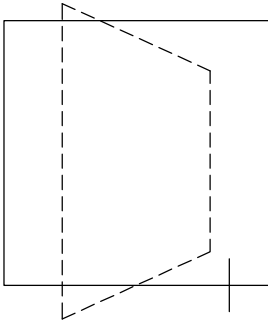

16

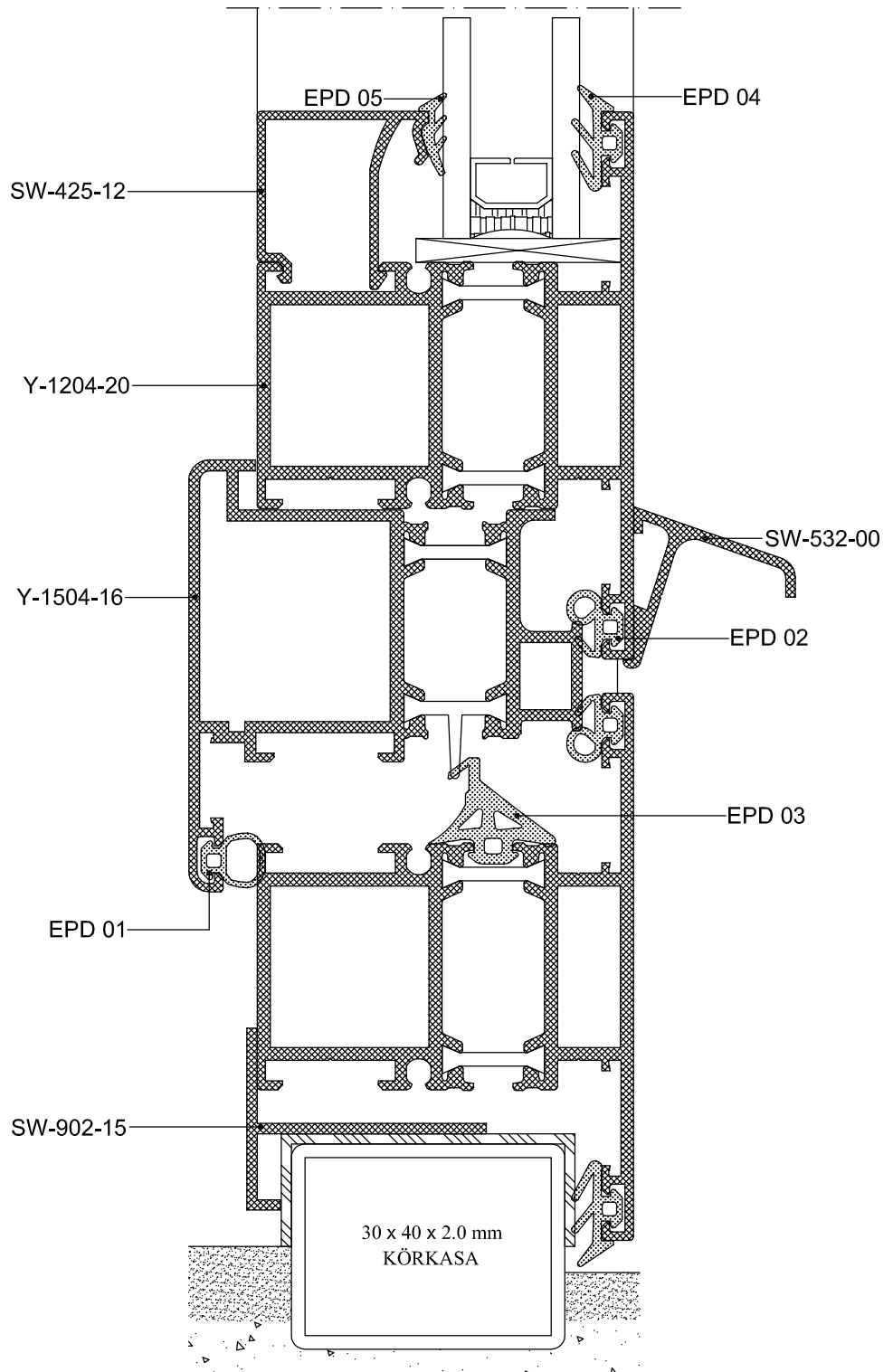

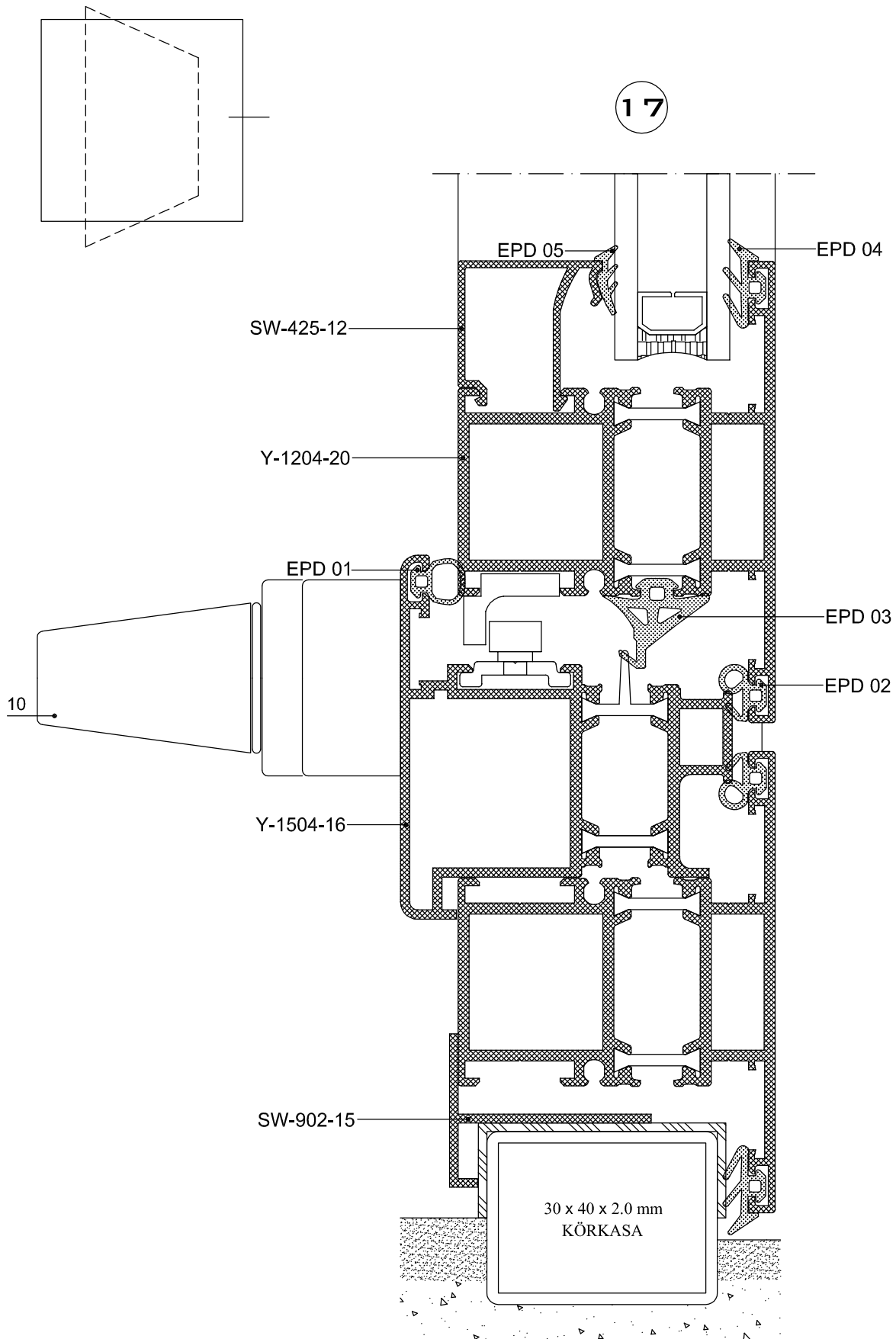

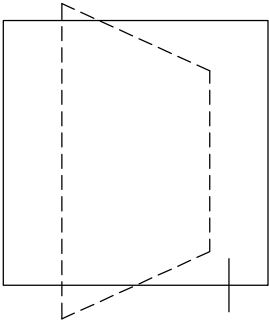

18

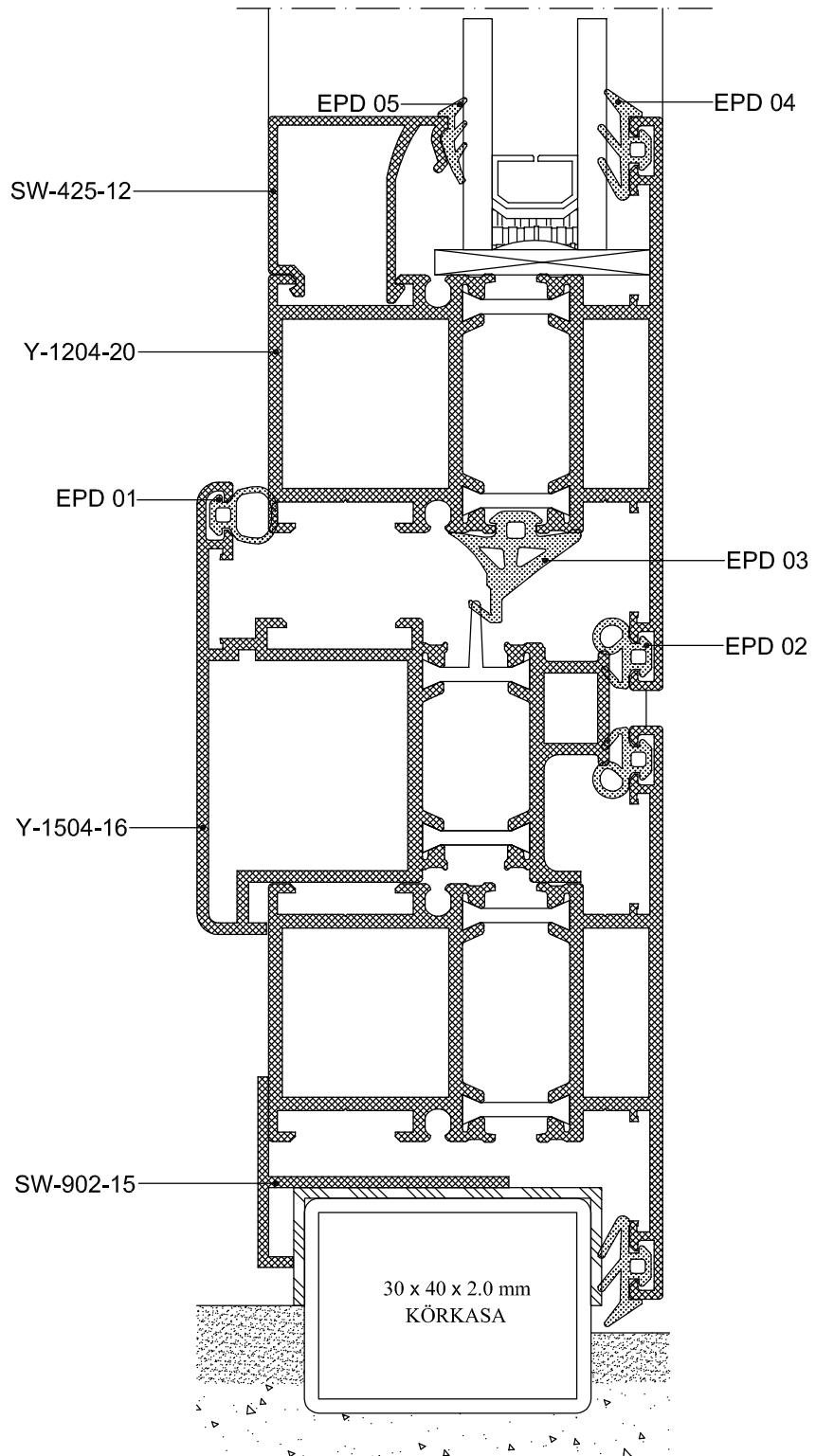

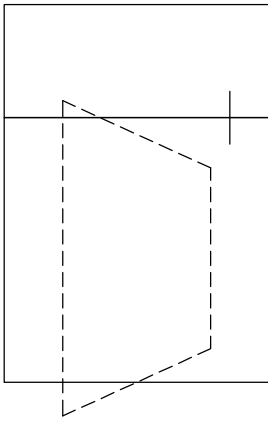

19

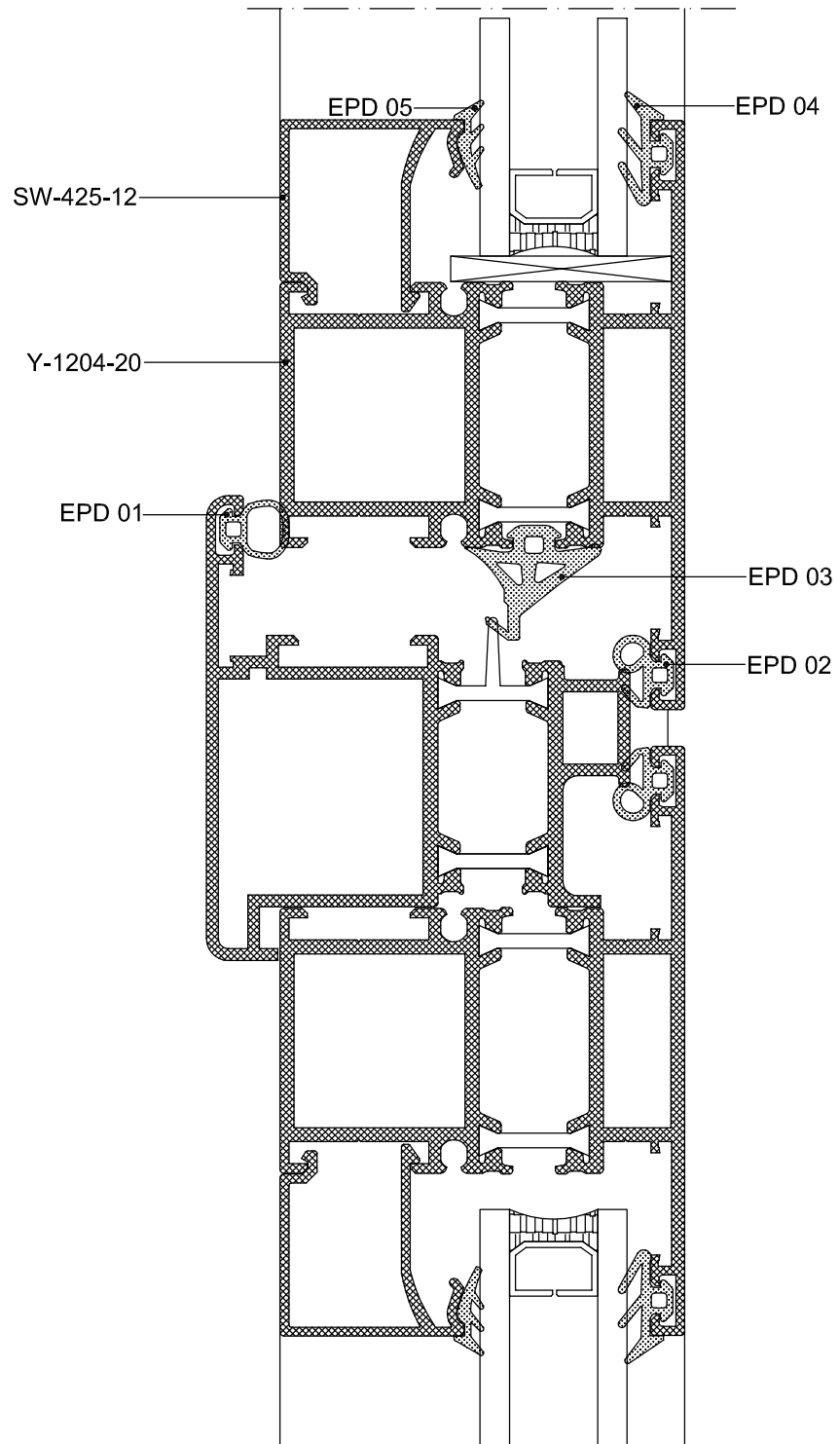

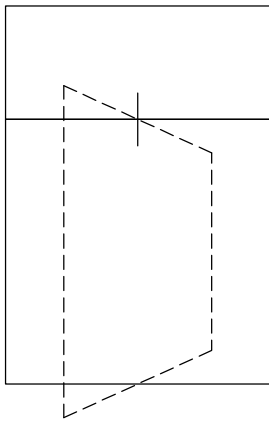

20

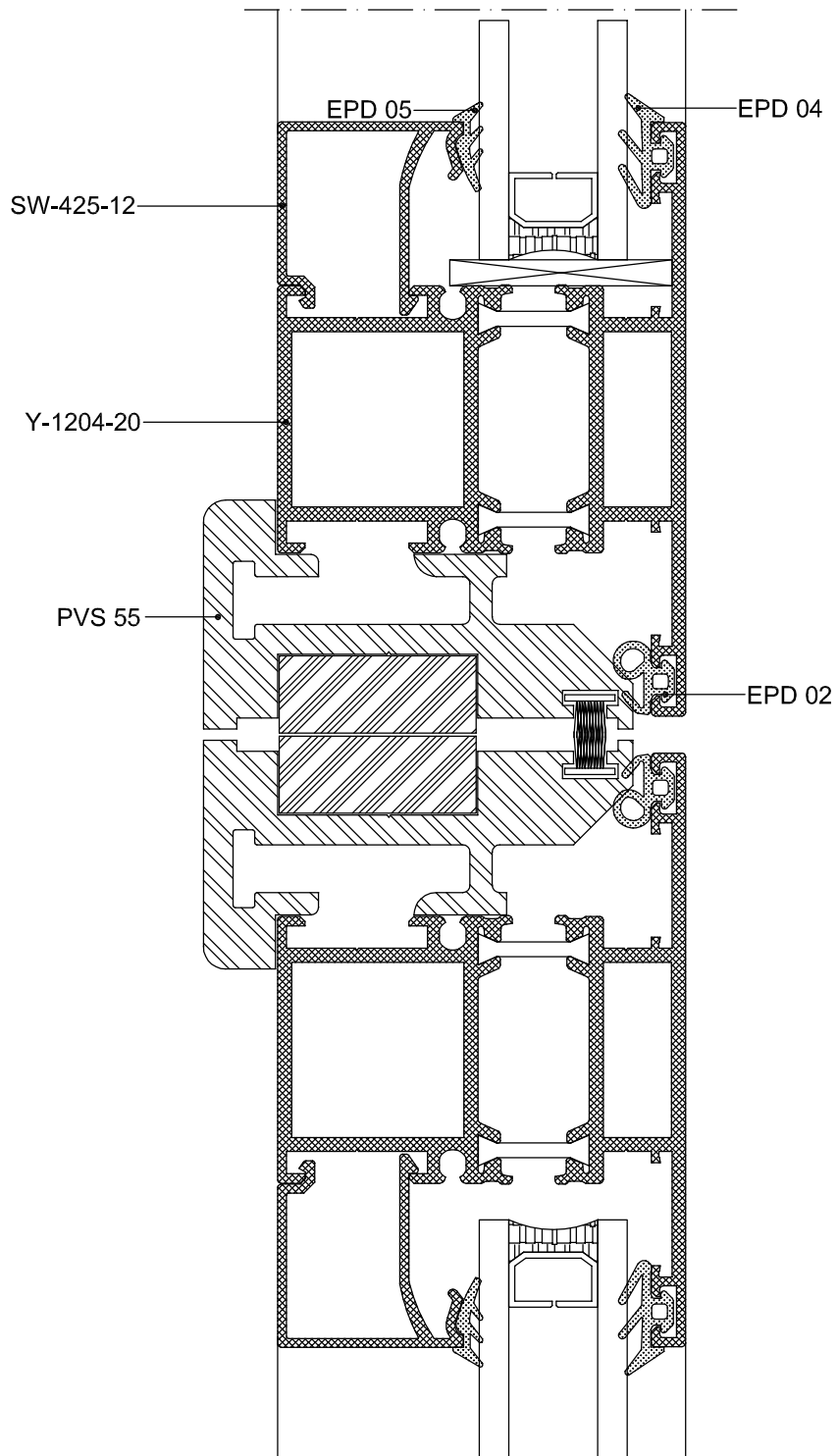

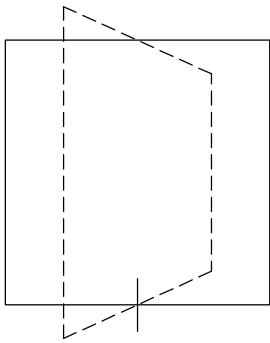

21

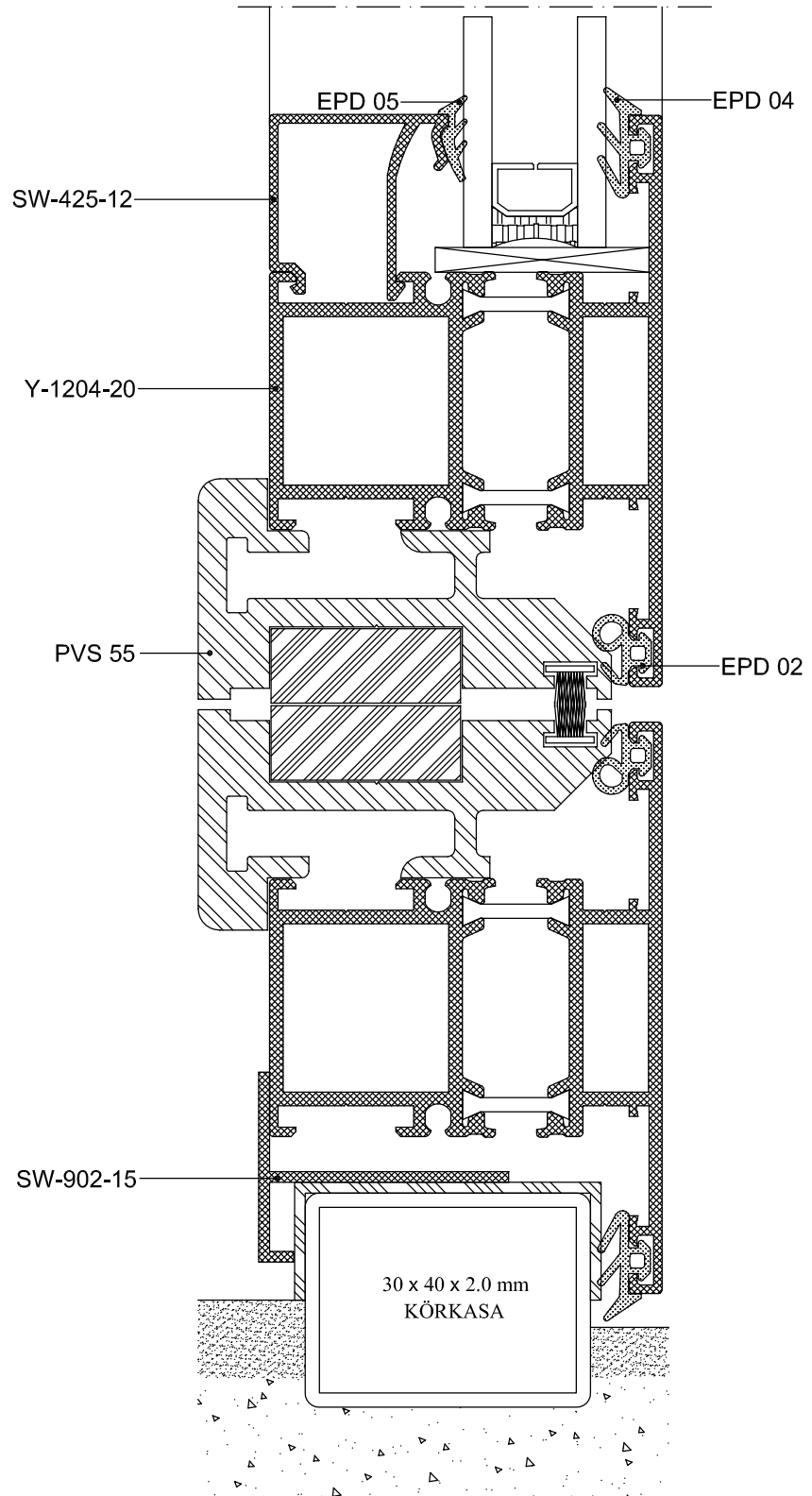

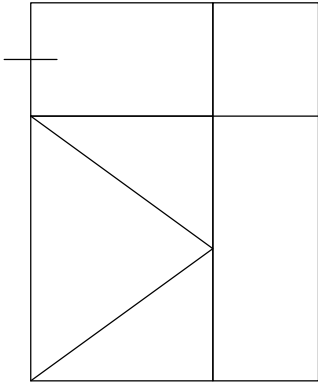

22

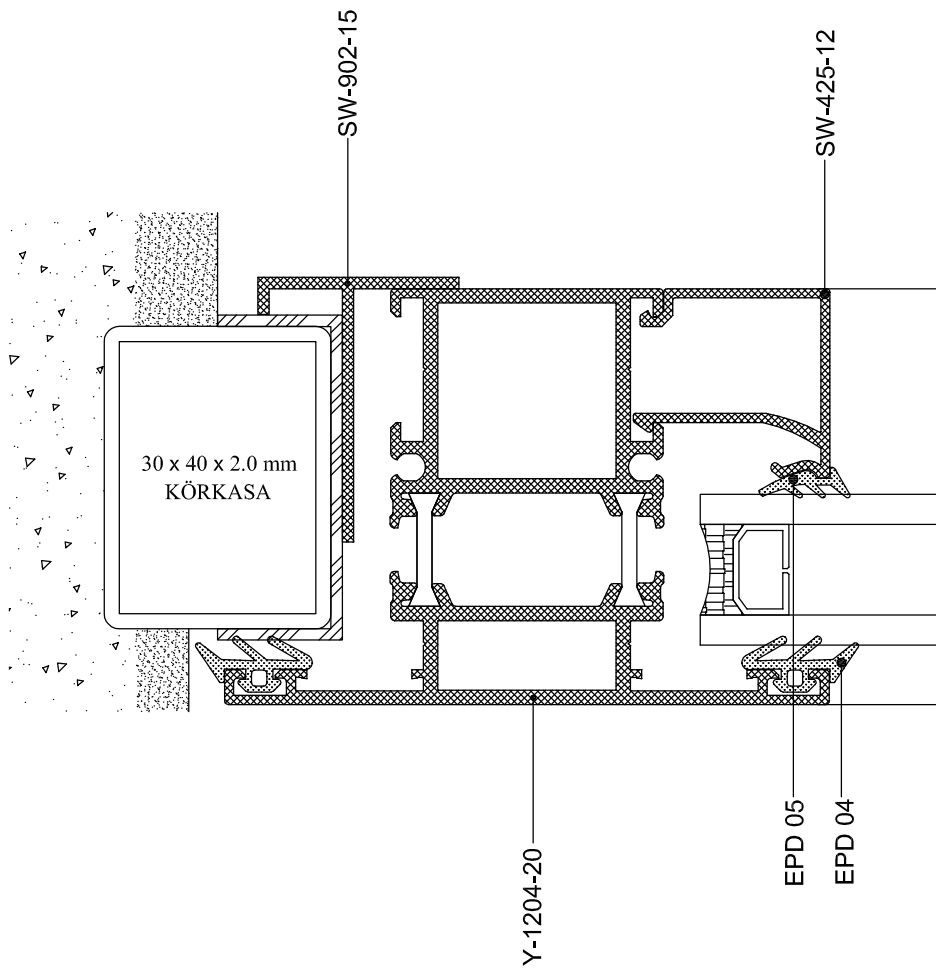

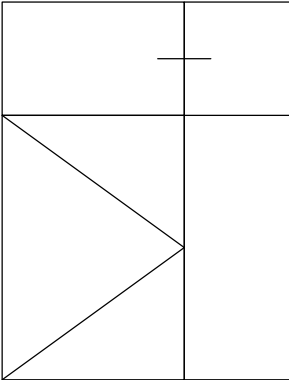

23

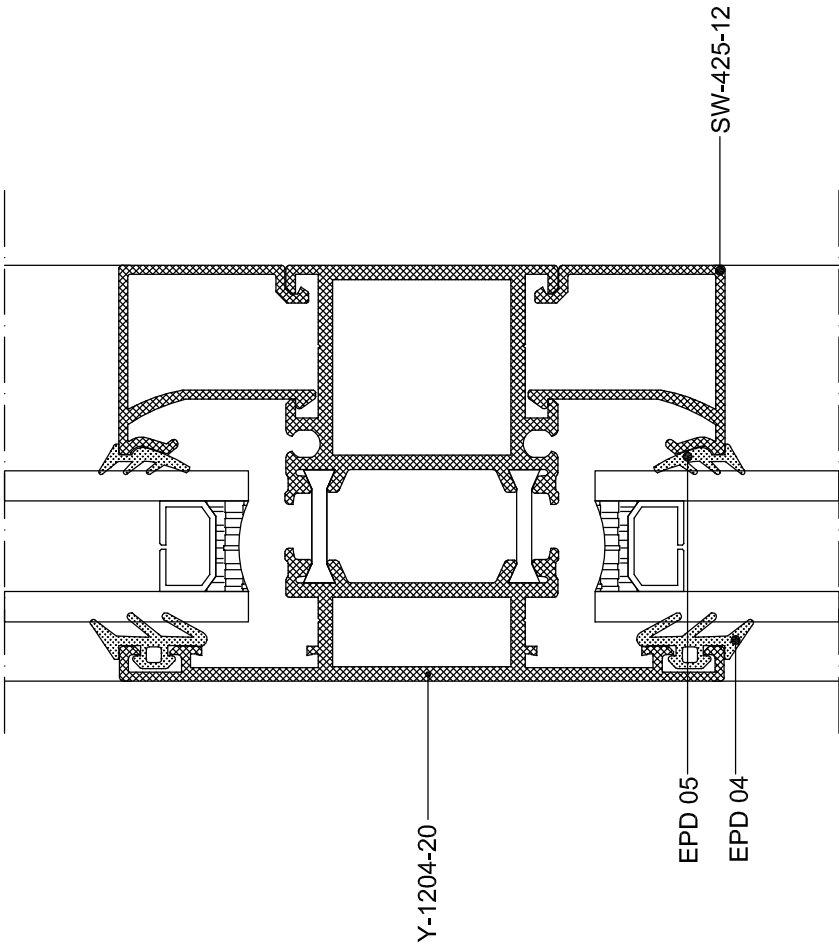

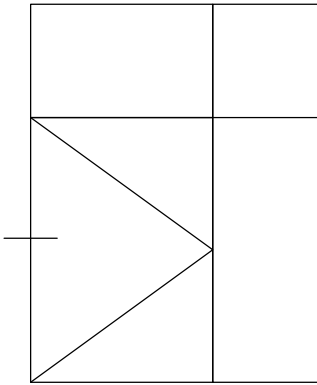

24

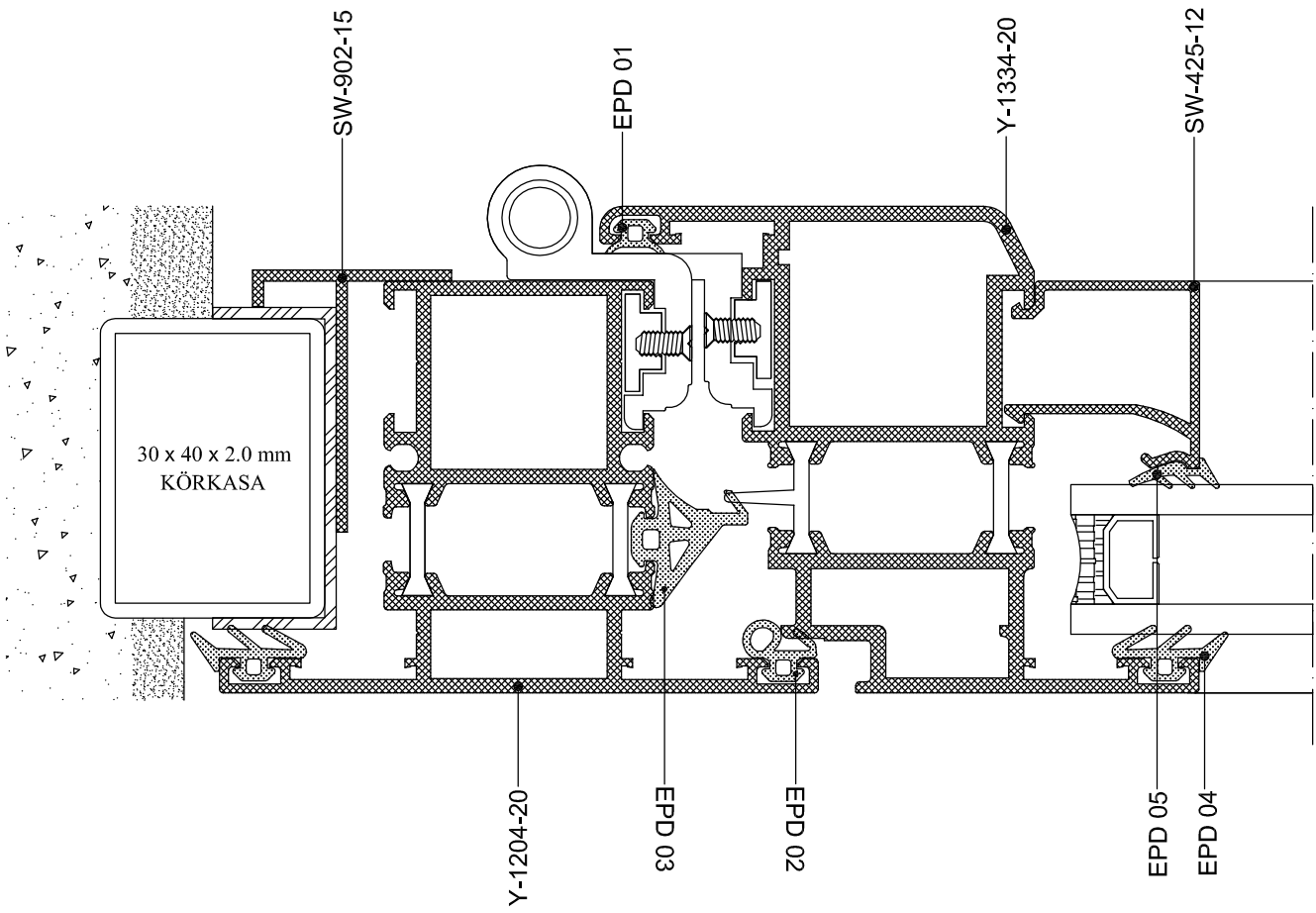

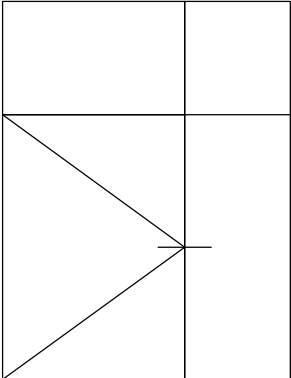

25

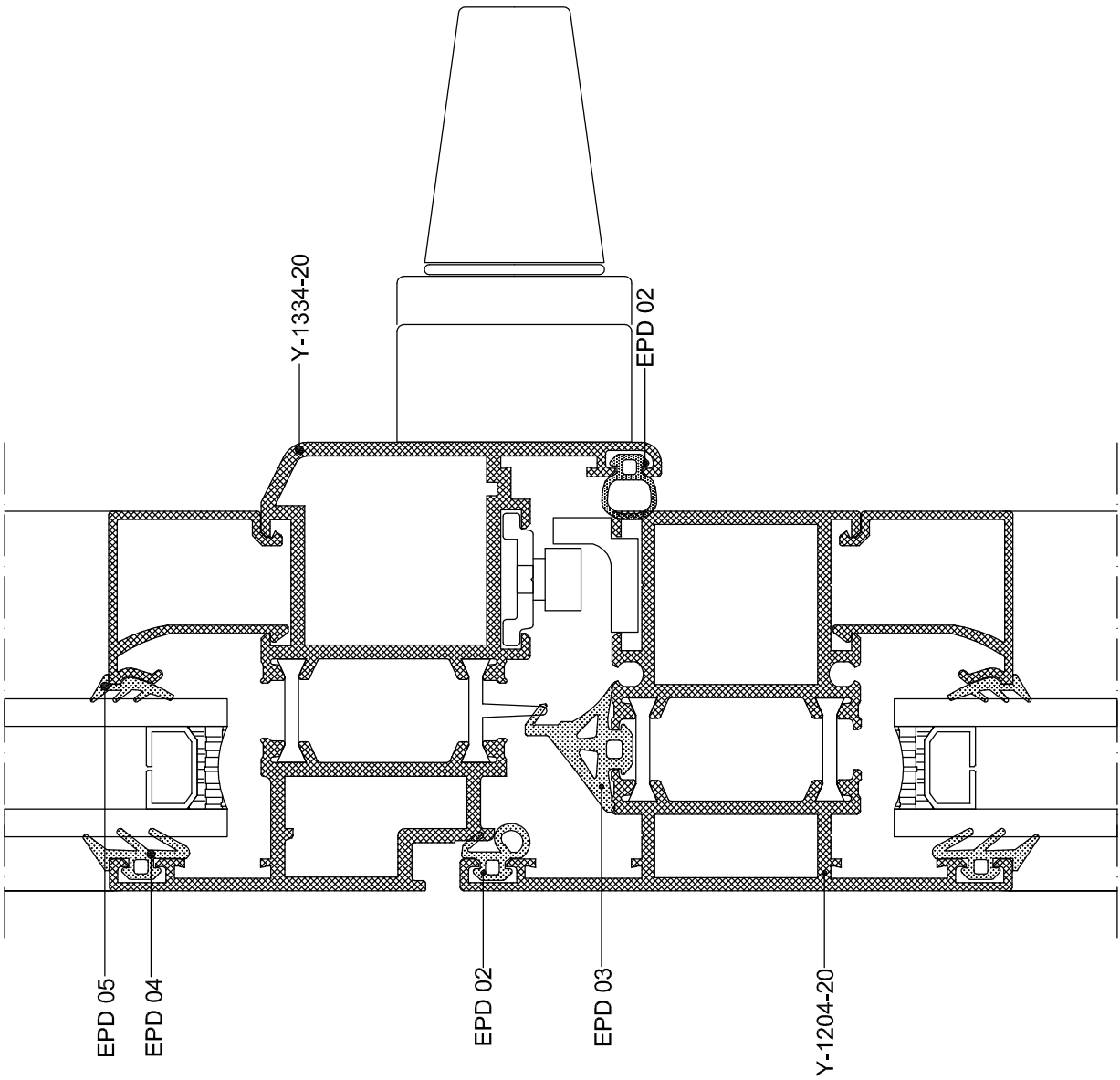

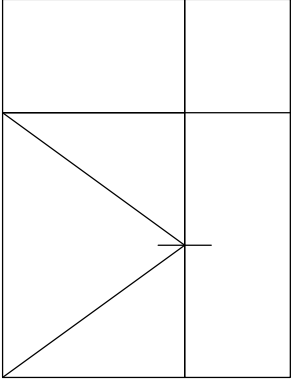

İSPANYOLET İLE KANAT
TEŞKİLİ

25*

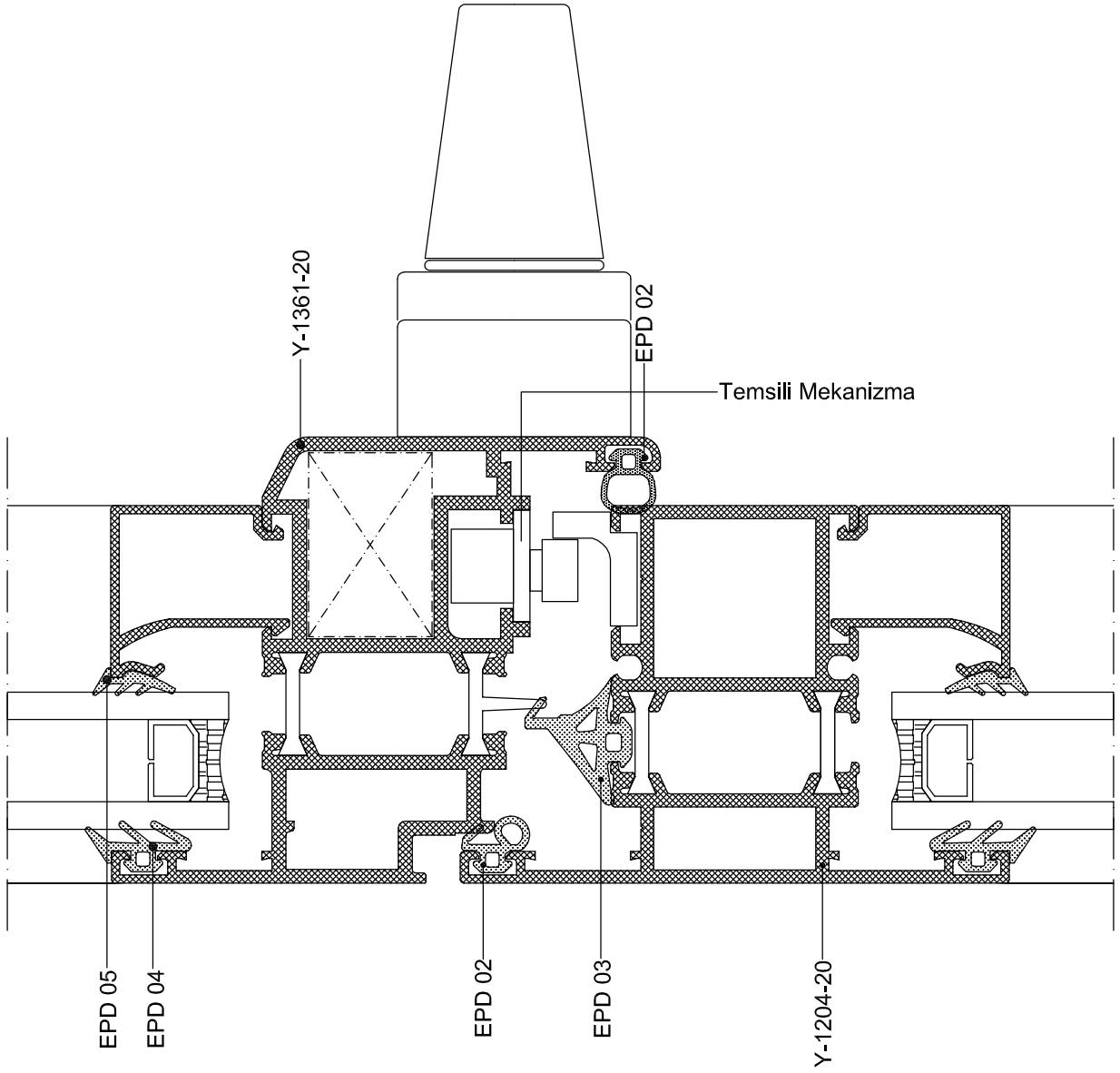

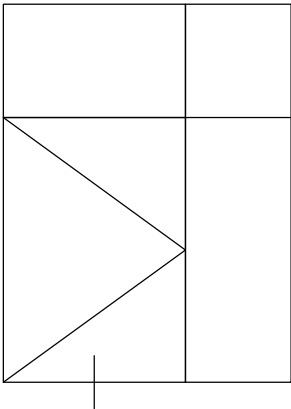

26

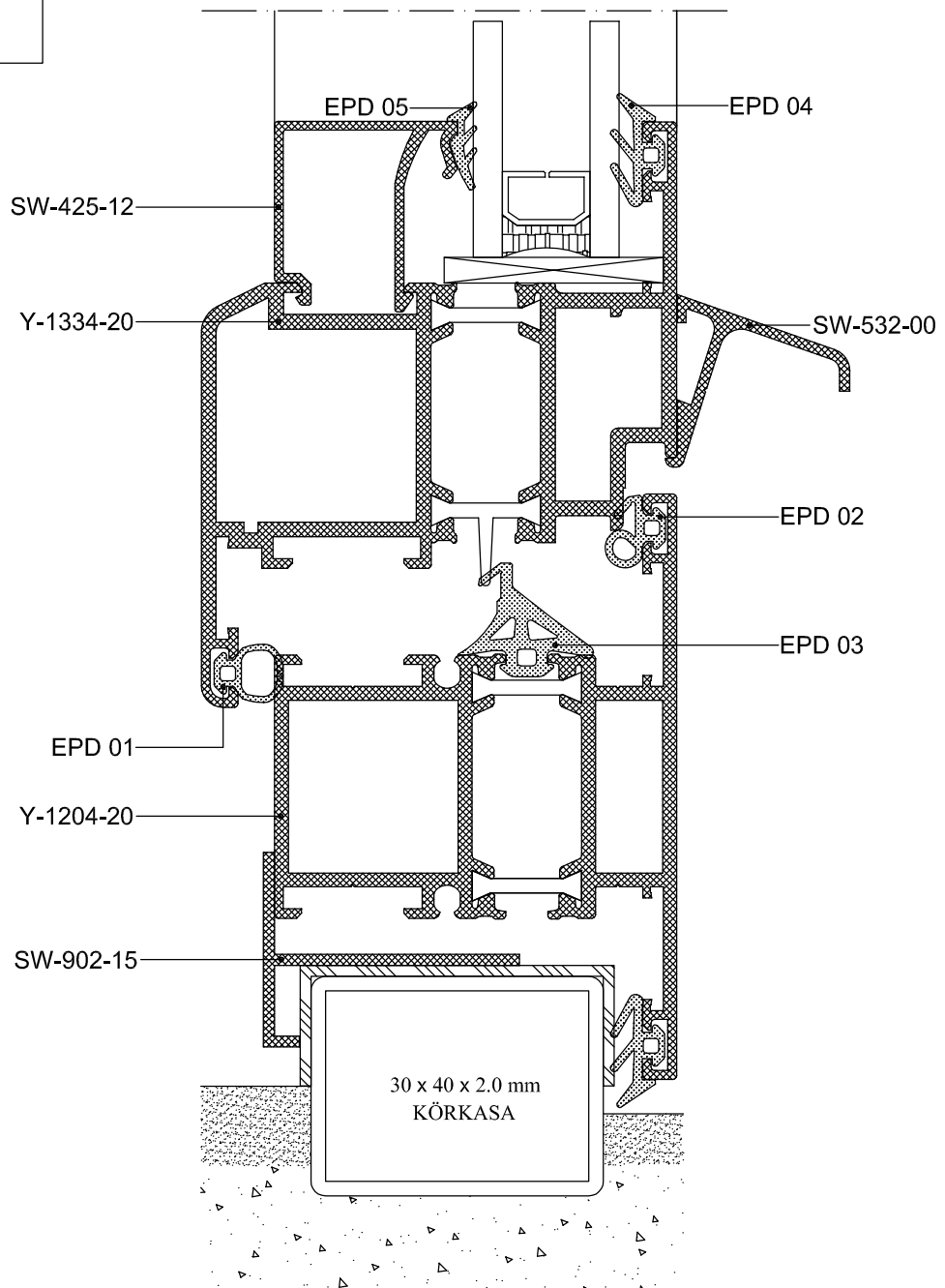

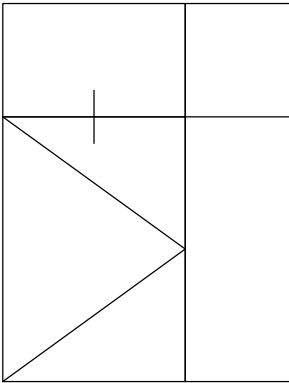

27

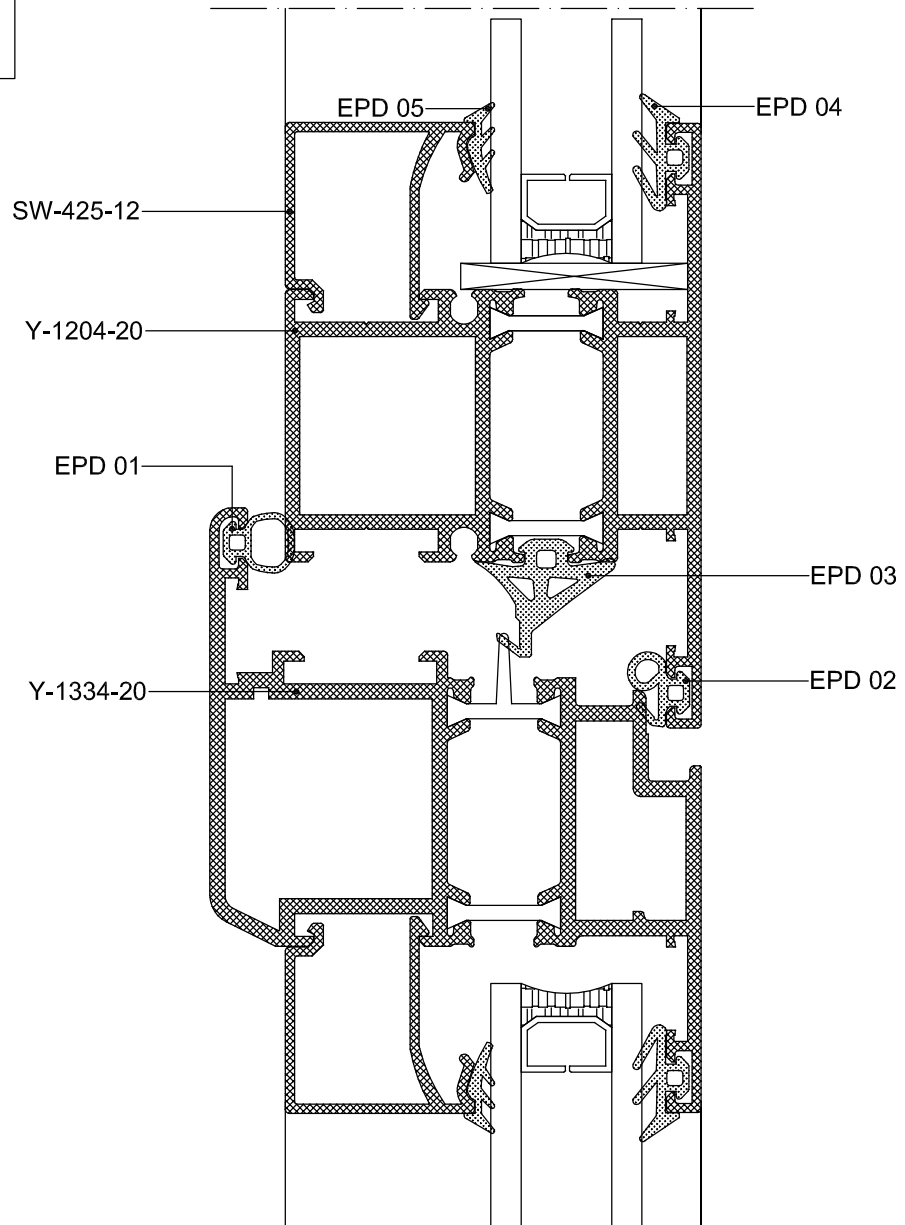

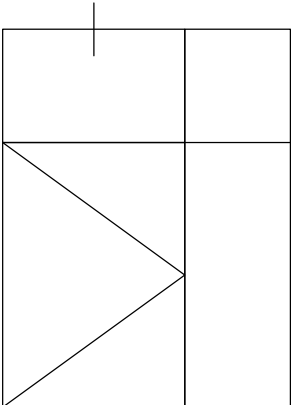

28

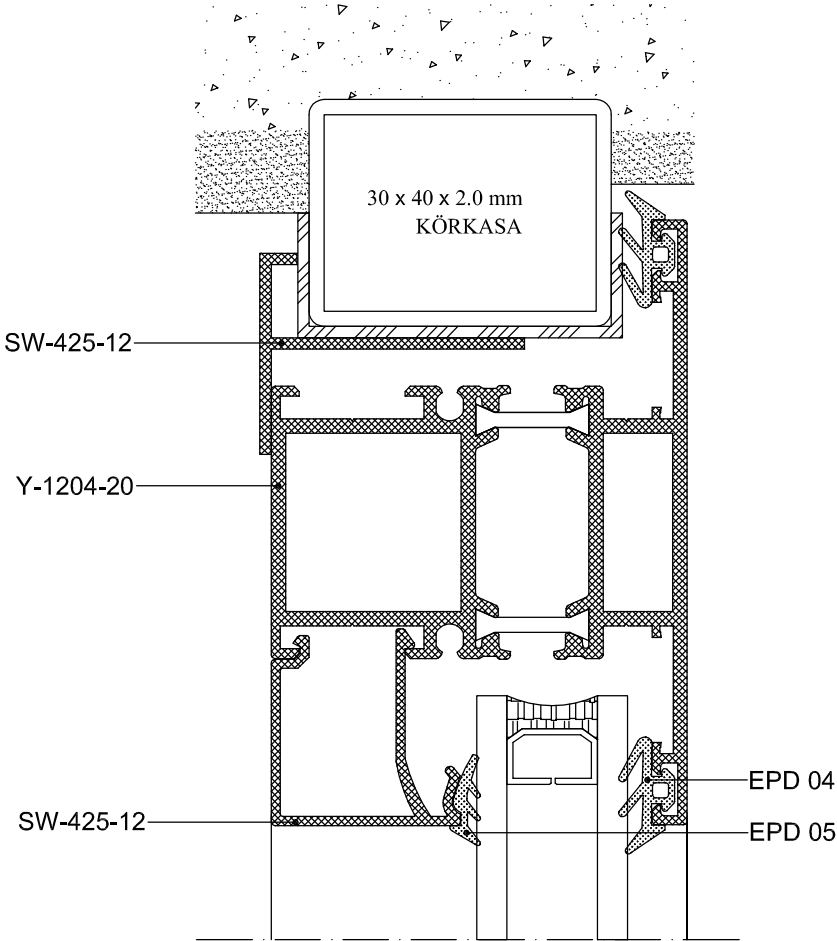

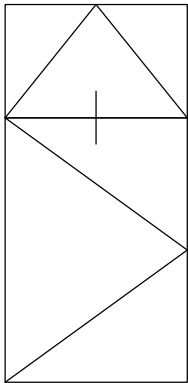

29

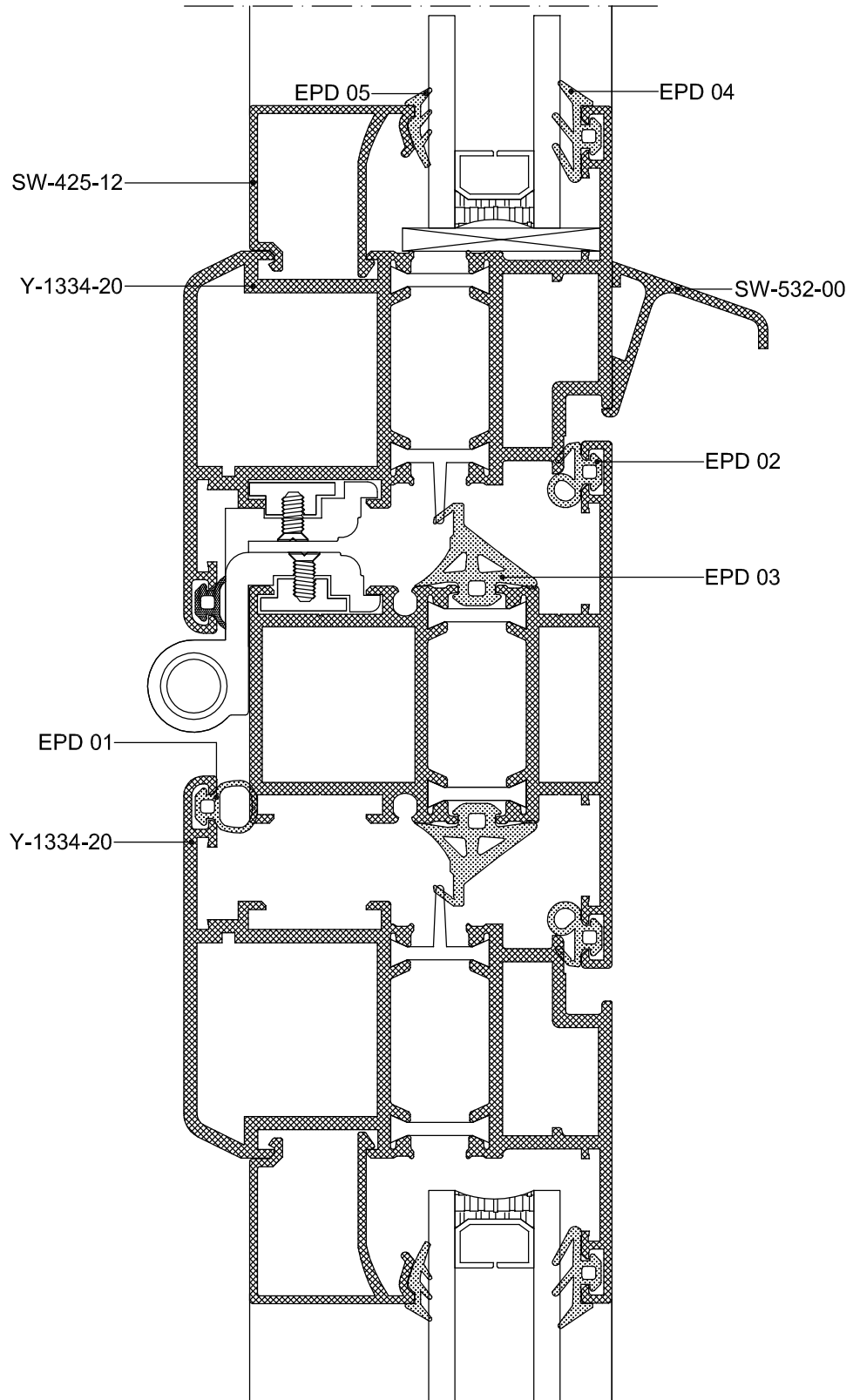

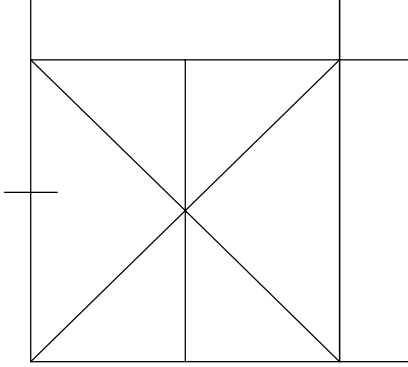

DIŐA AÇILIR KAPI UYGULAMA DETAYLARI

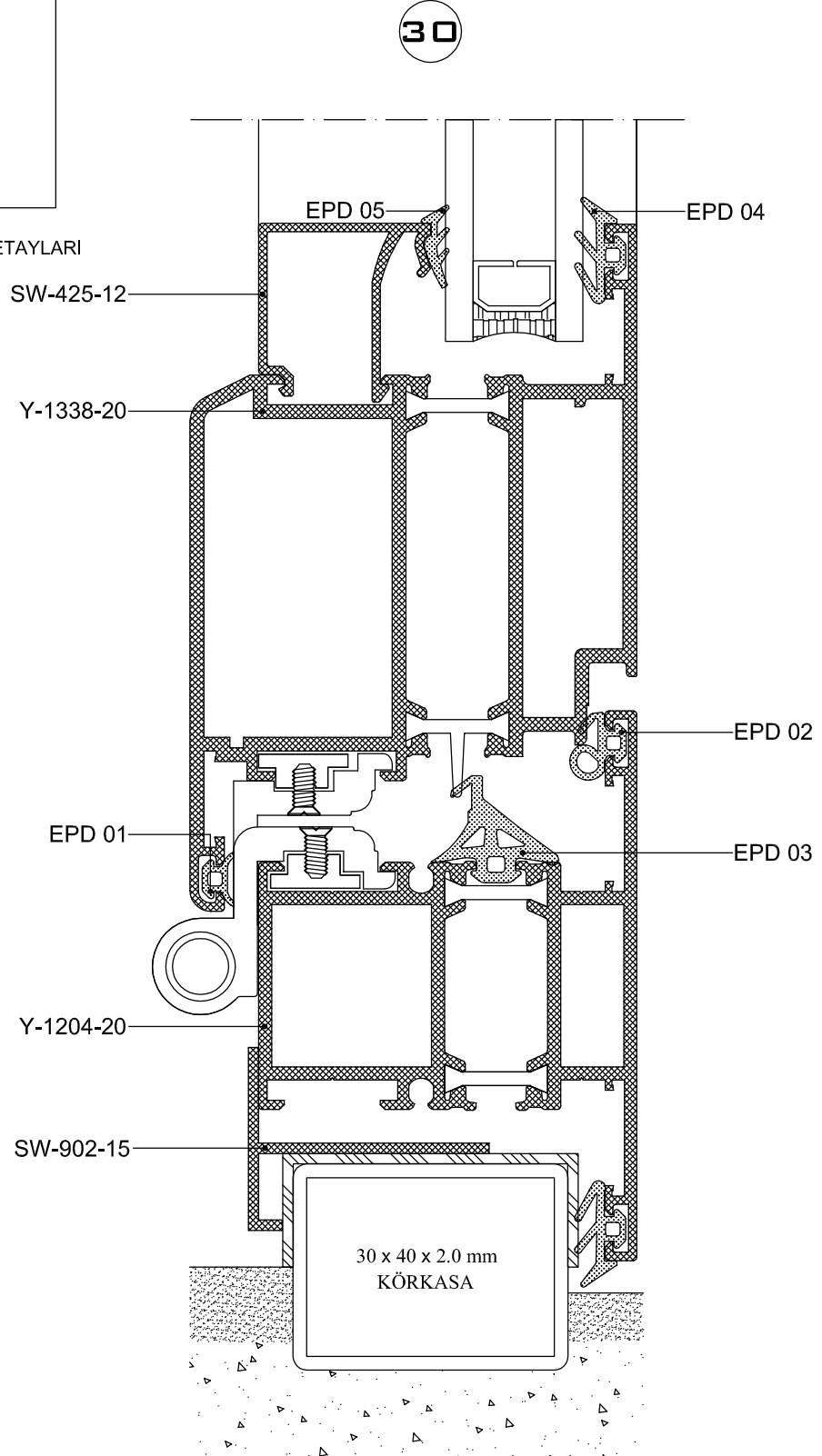

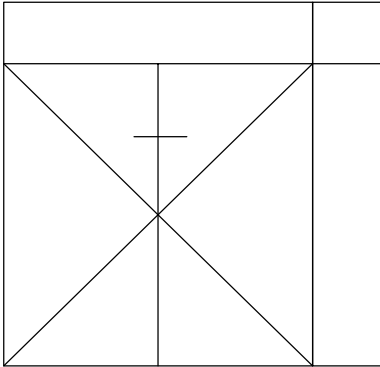

31

KALE 153 KILIT
164 GNC 76 LIK BAREL

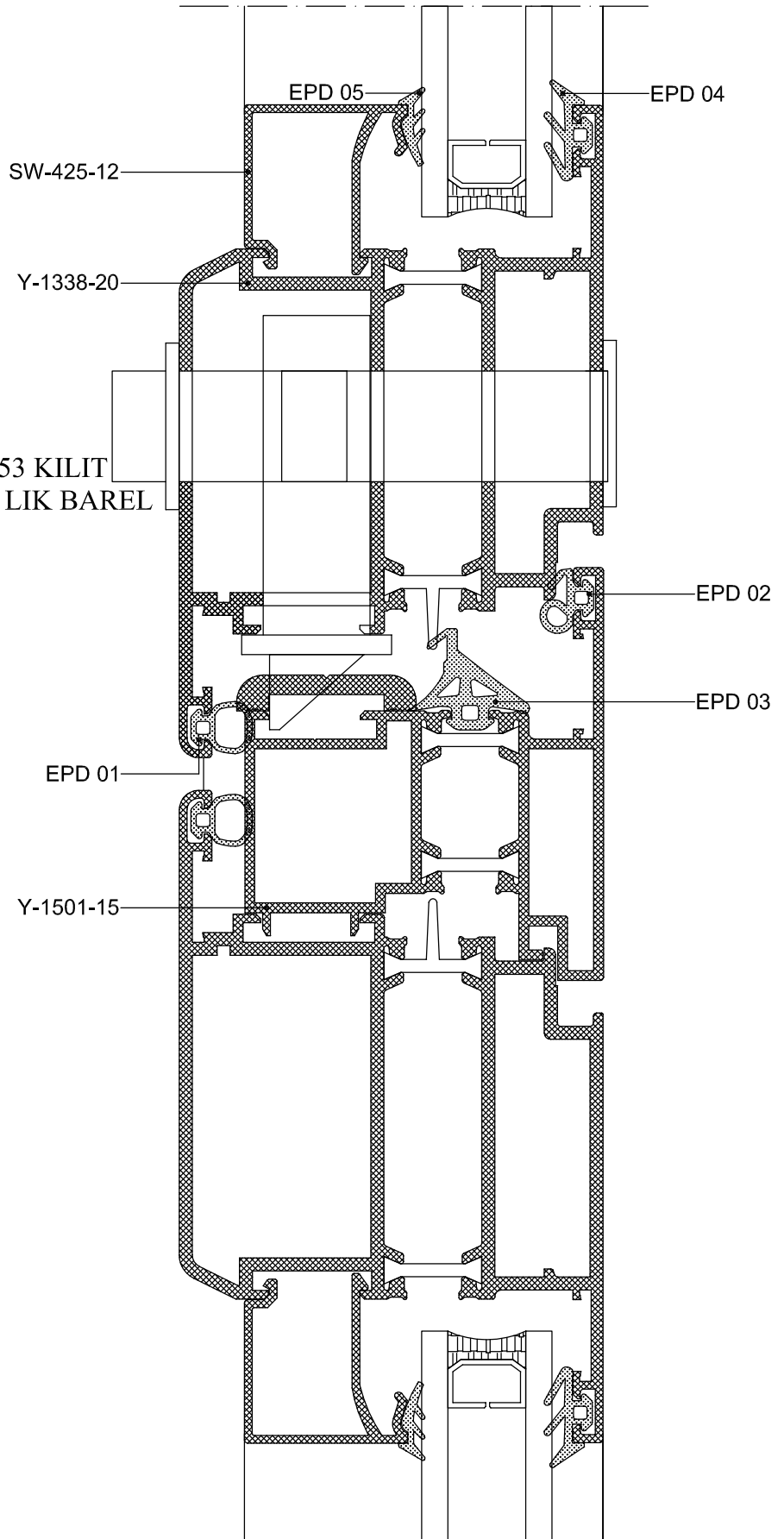

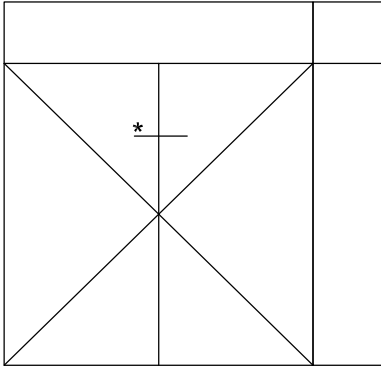

32

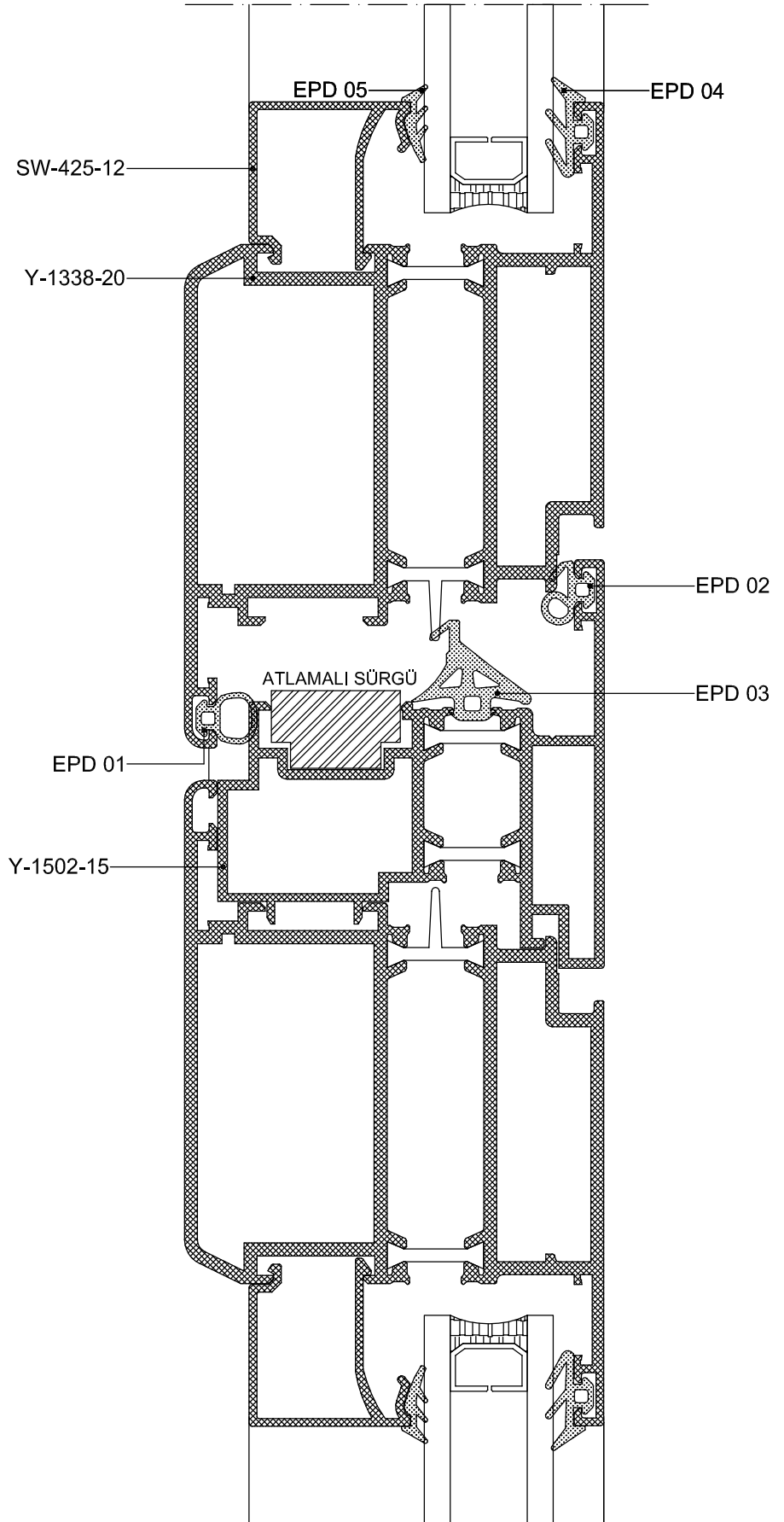

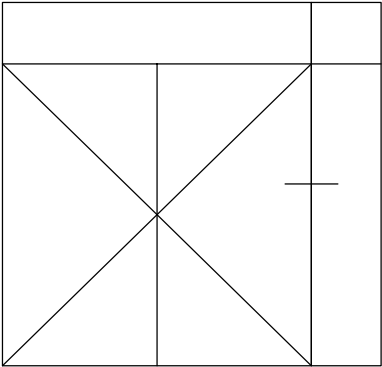

33

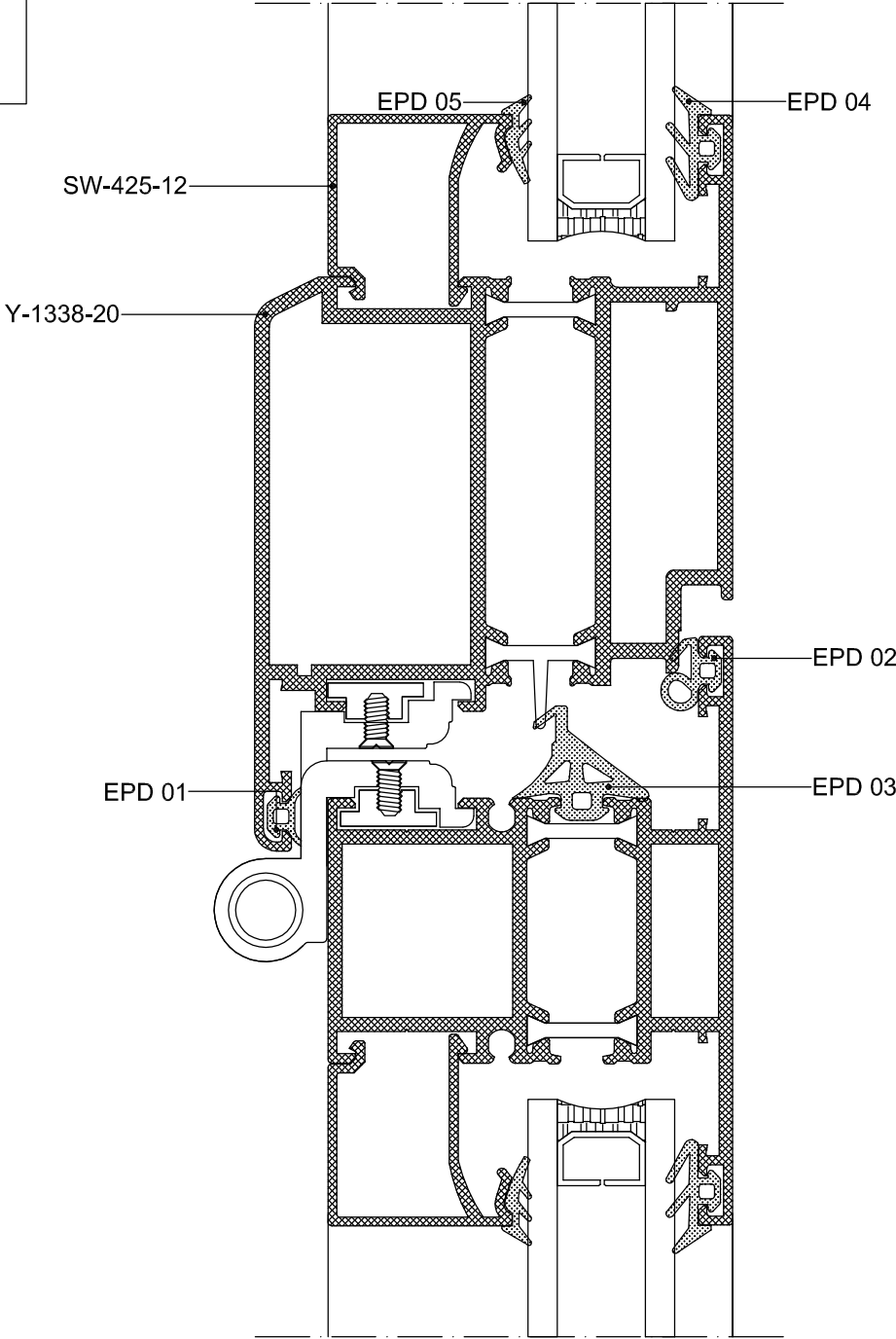

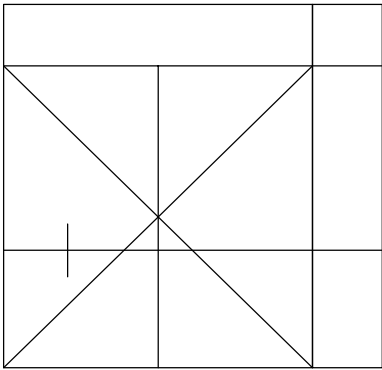

34

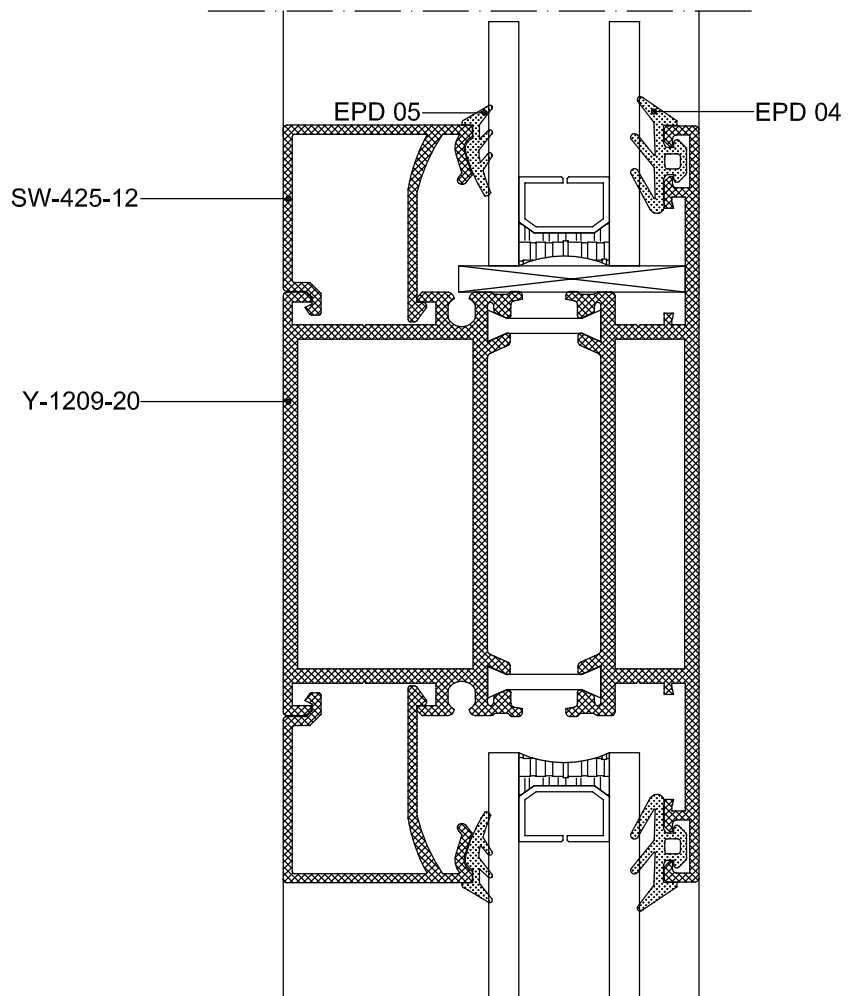

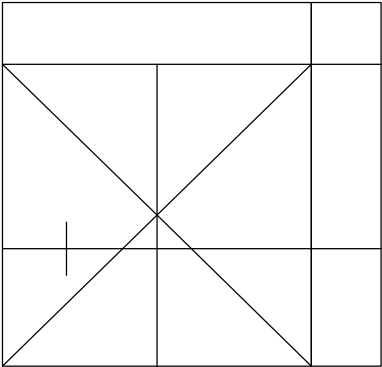

35

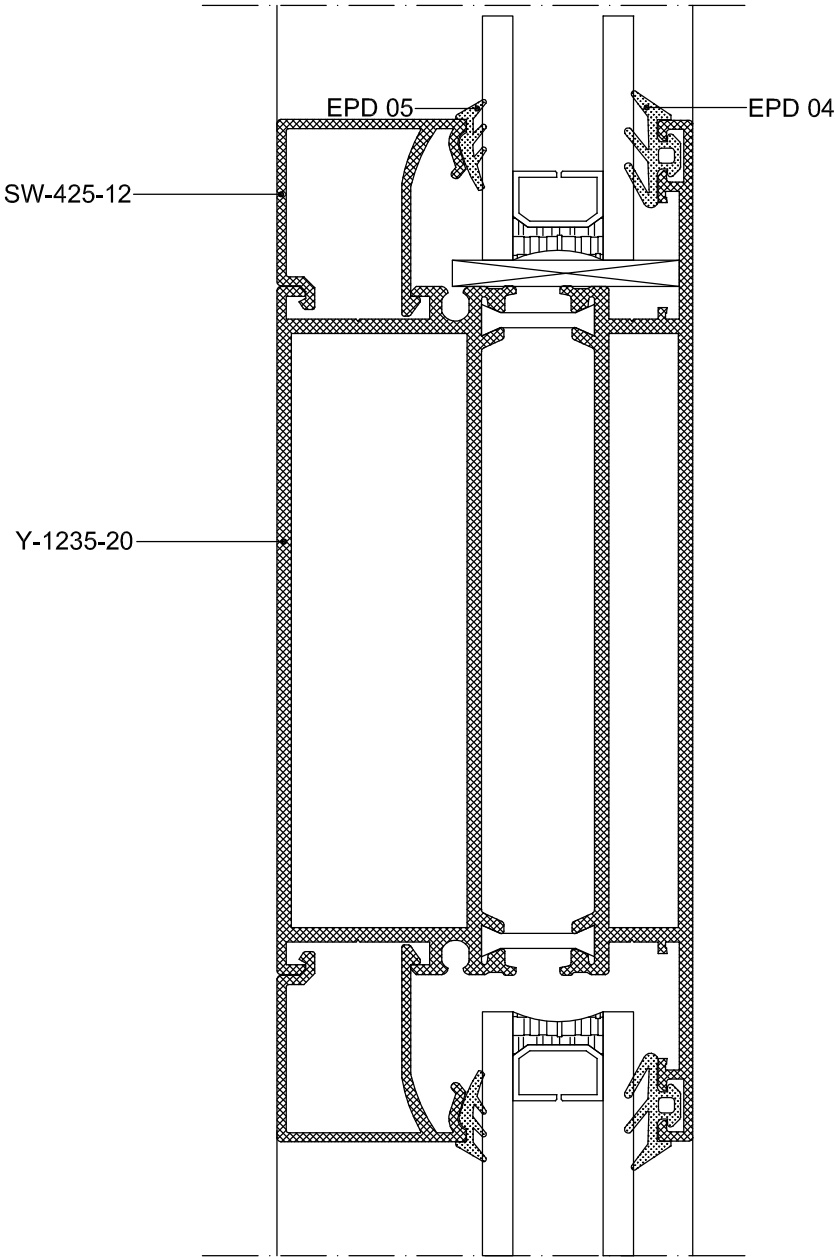

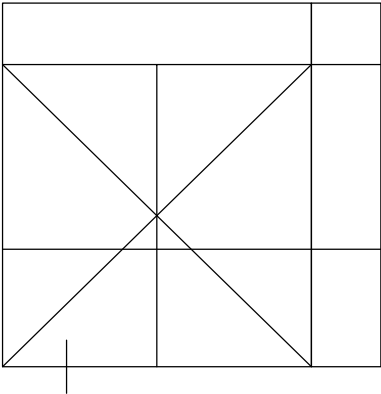

36

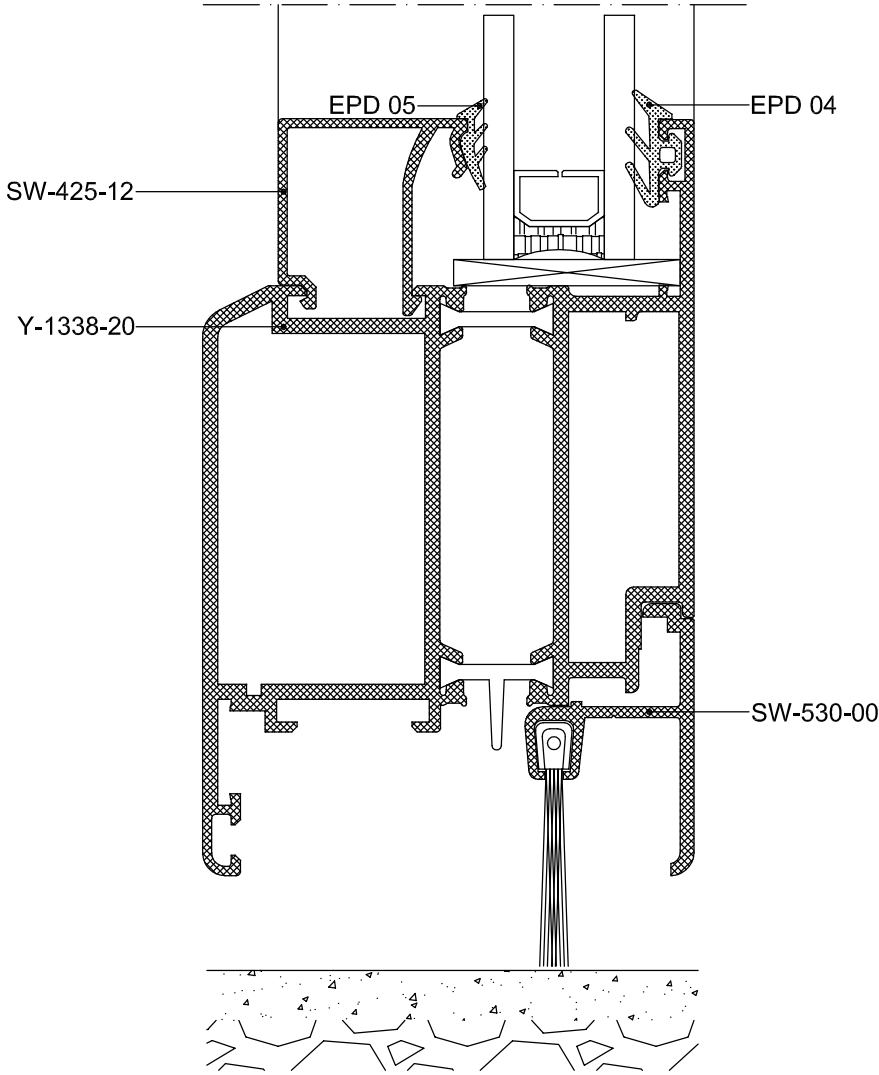

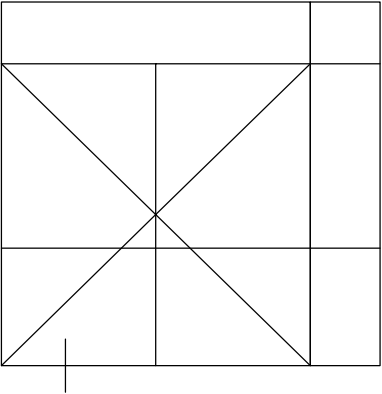

37

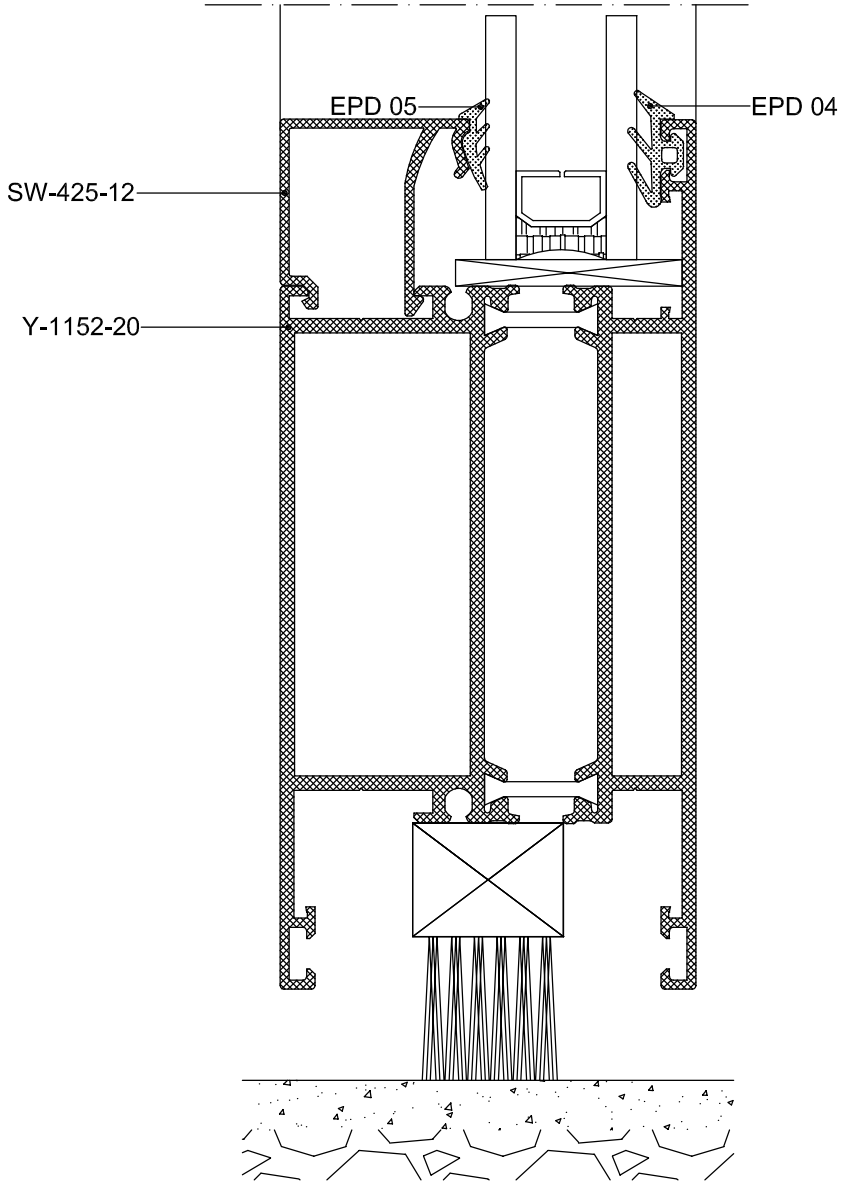

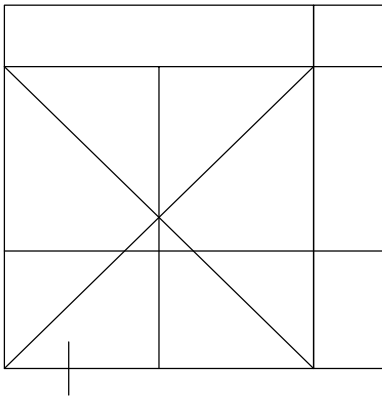

38

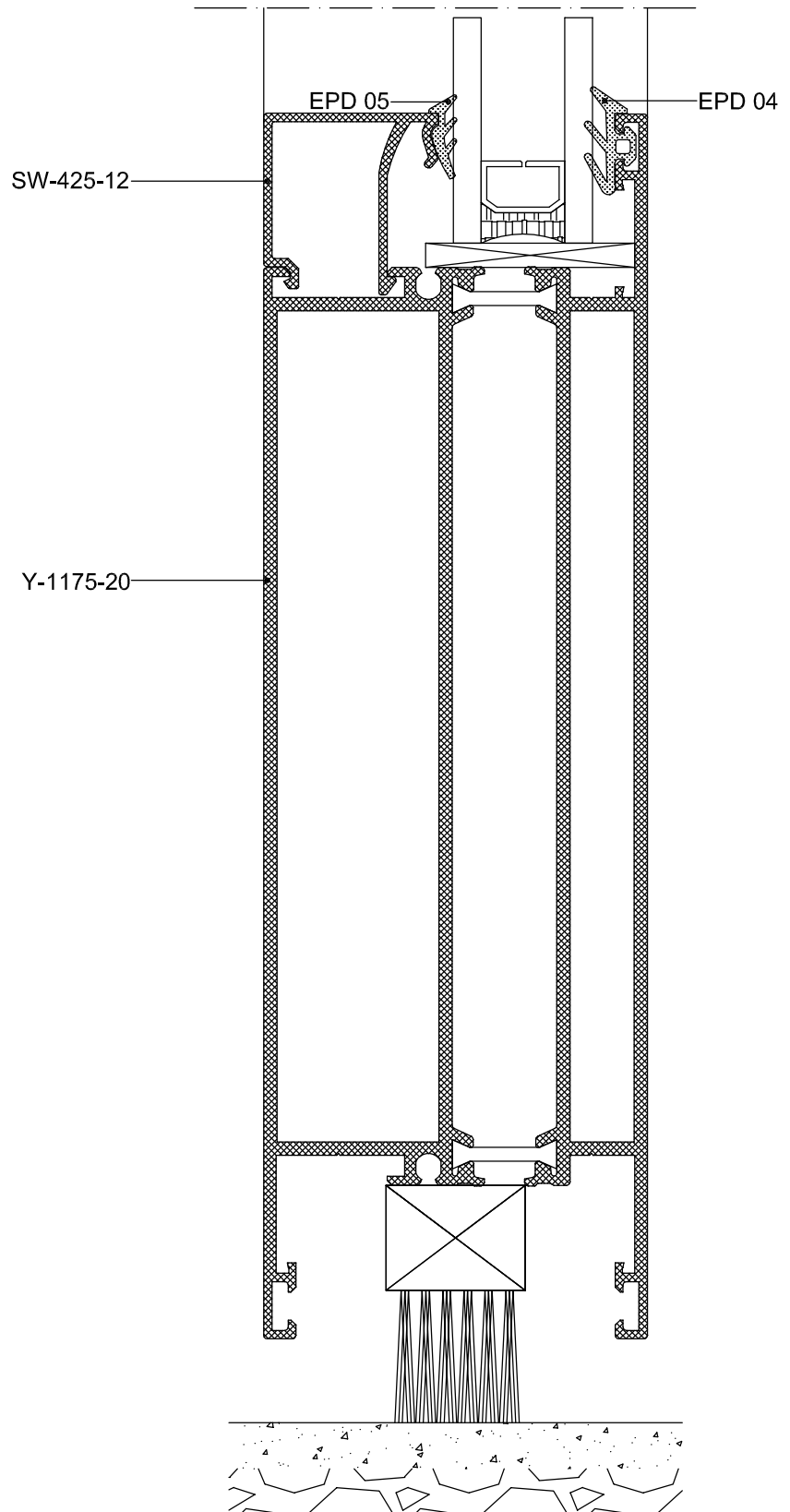

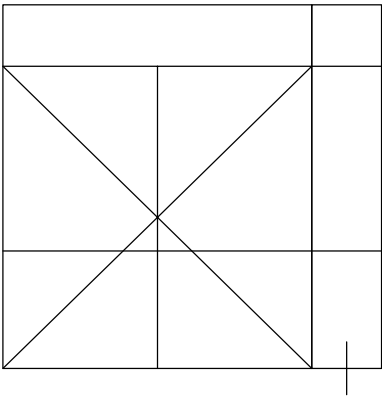

39

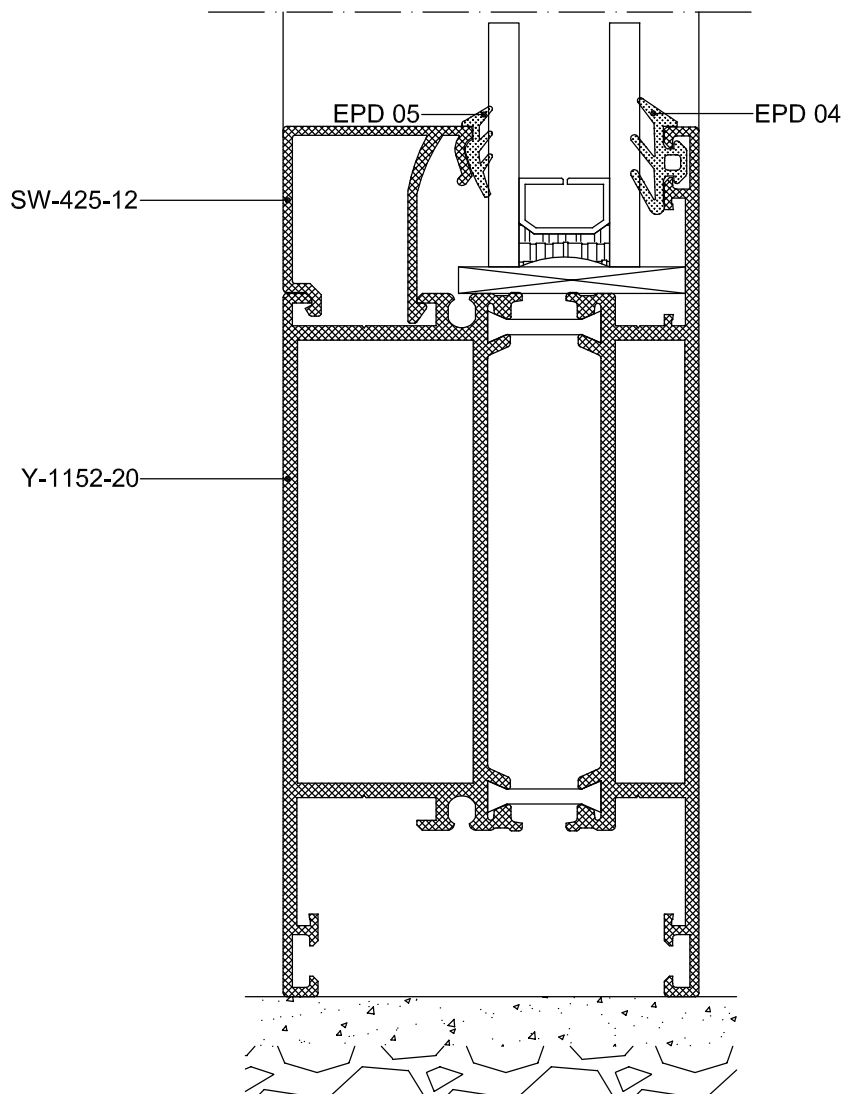

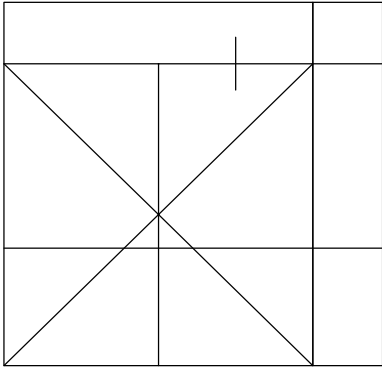

40

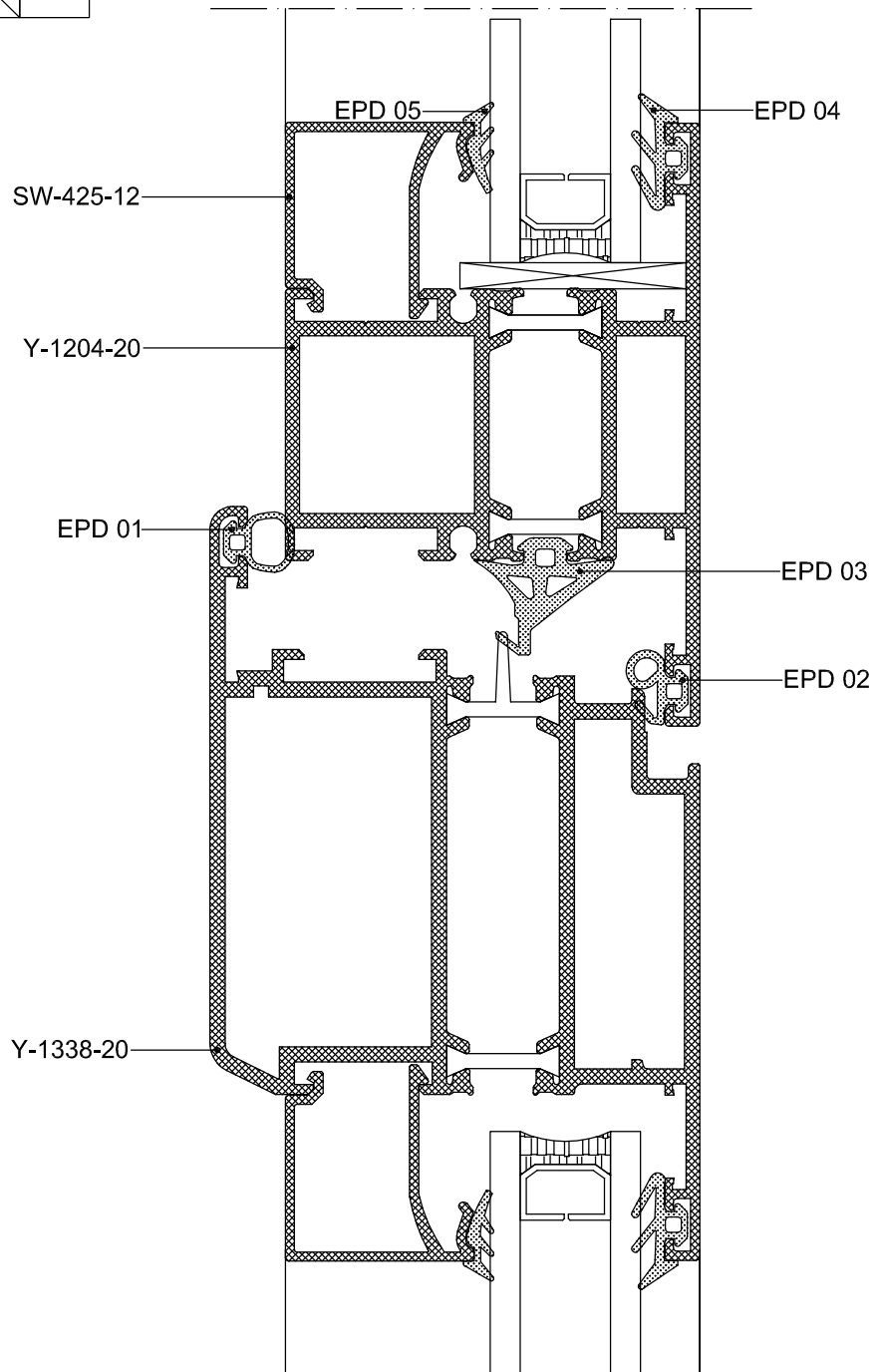

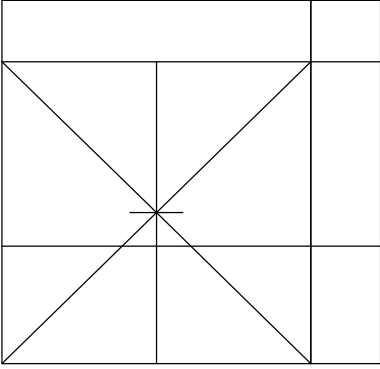

KİLİT MONTAJ ÖRNEK DETAYI

KALE 153 KİLİT
164 GNC 76 LİK BAREL

41

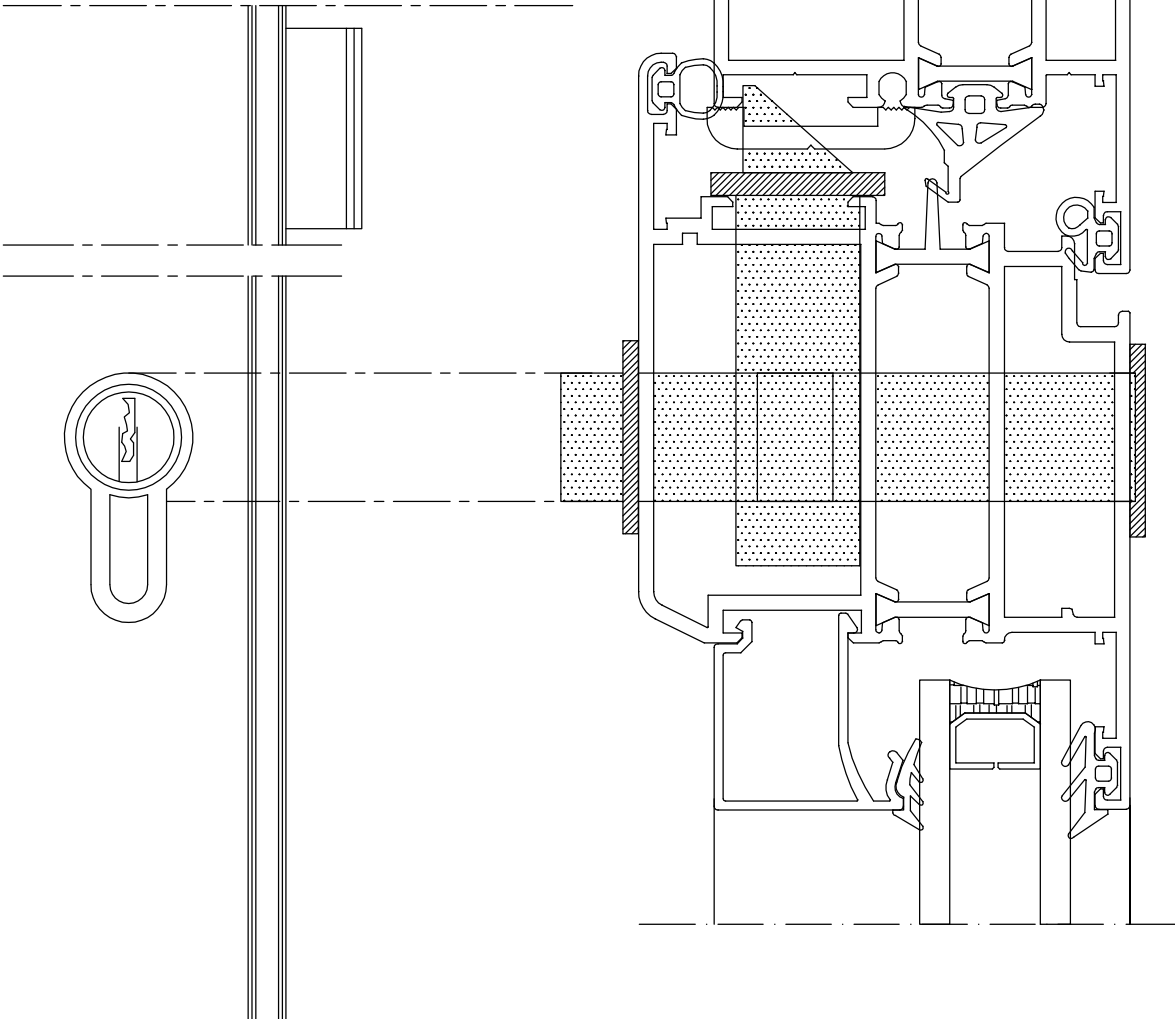

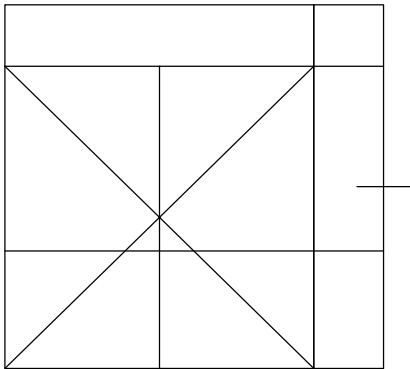

42

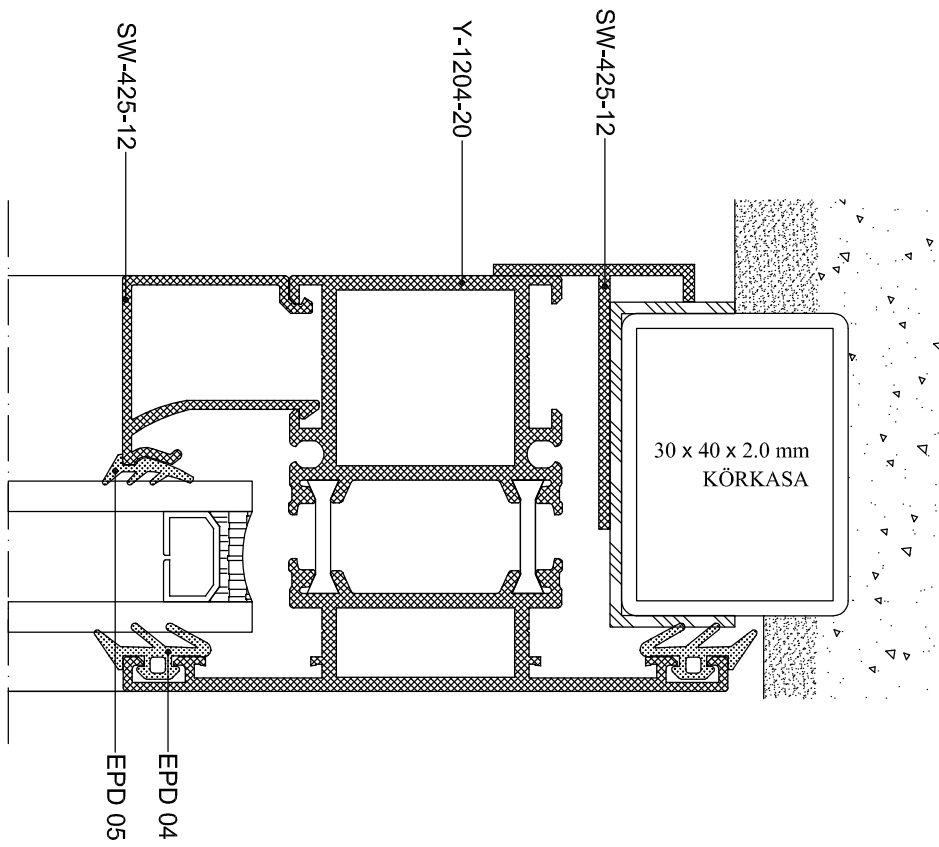

43

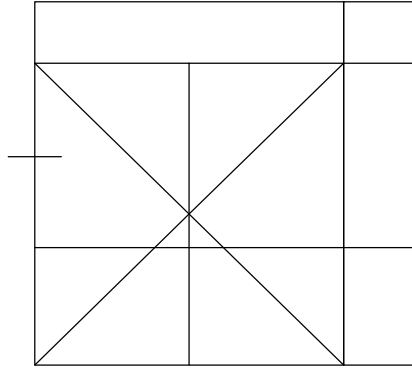

DIŐA AÇILIR KAPI UYGULAMA DETAYLARI

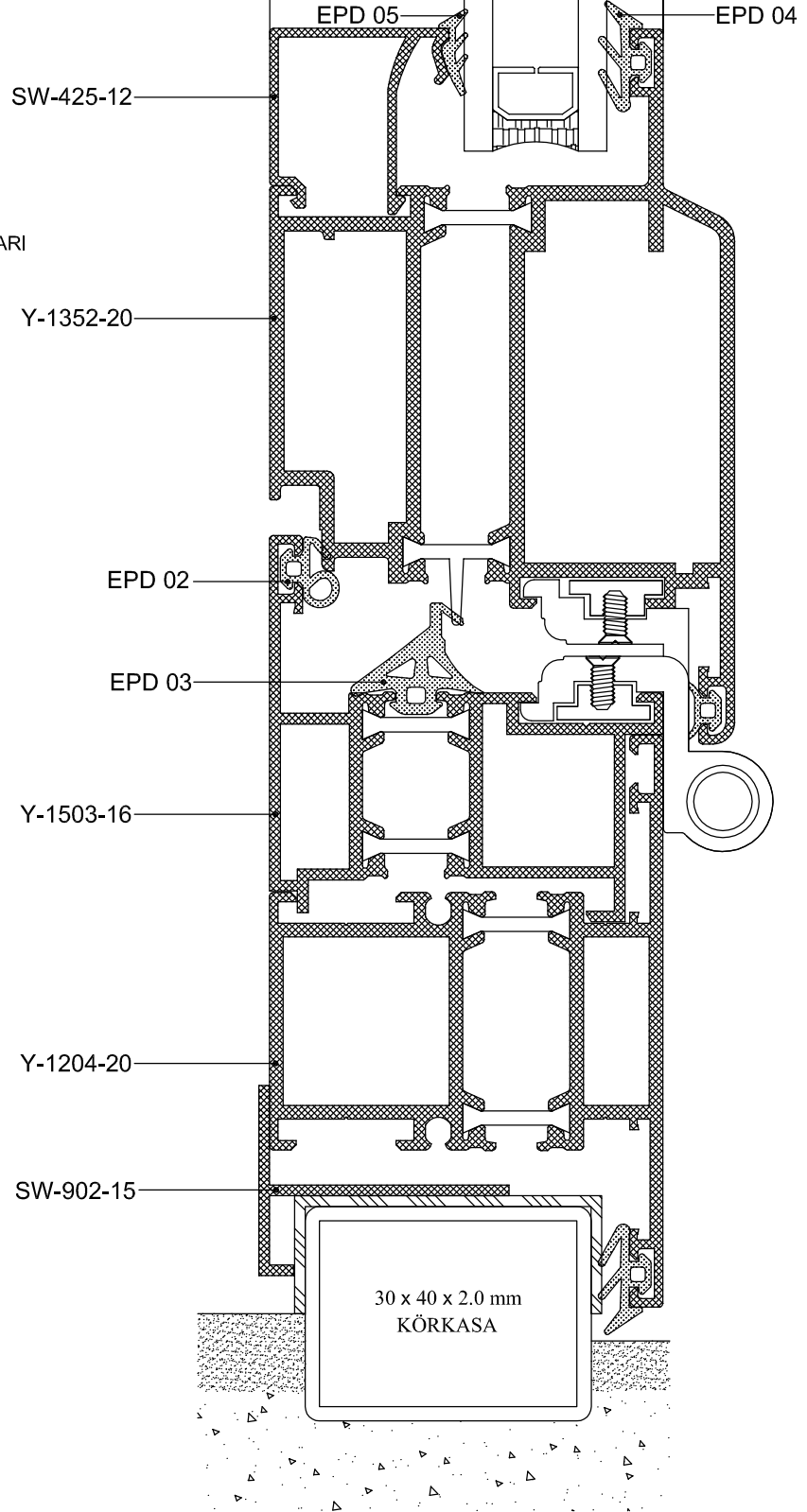

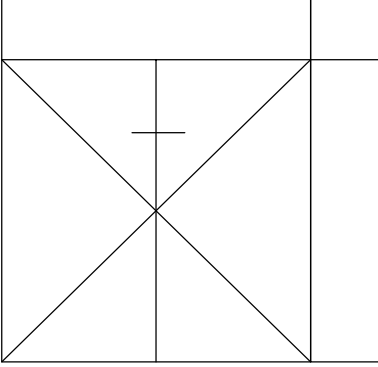

44

KİLİT MONTAJ ÖRNEK DETAYI

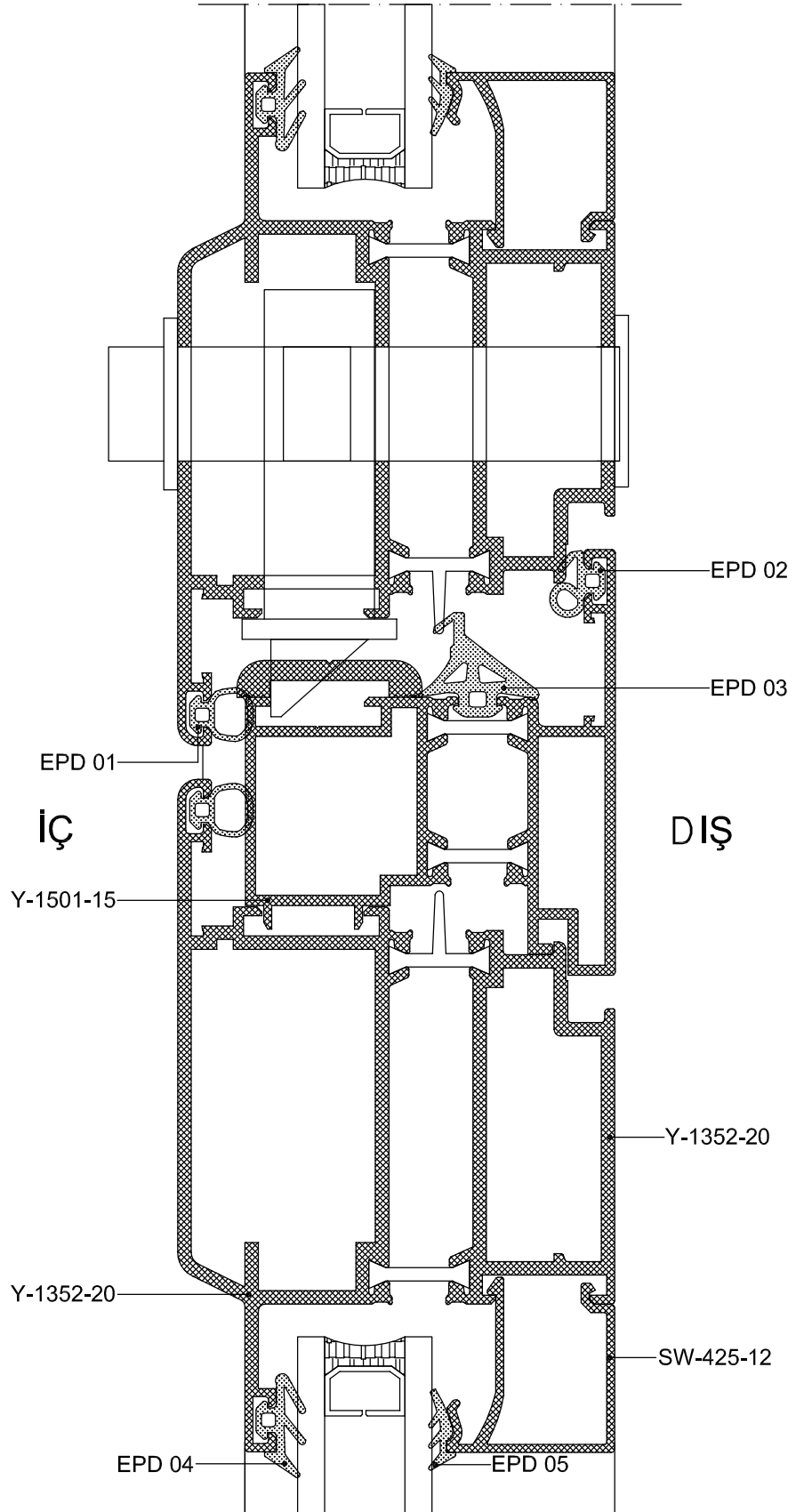
KALE 153 KİLİT
164 GNC 76 LİK BAREL

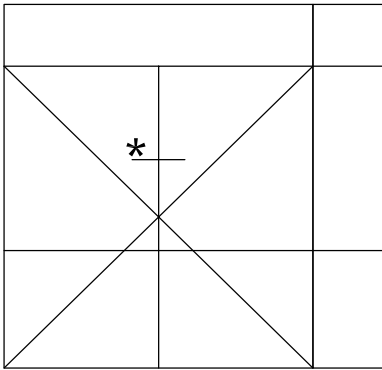

45

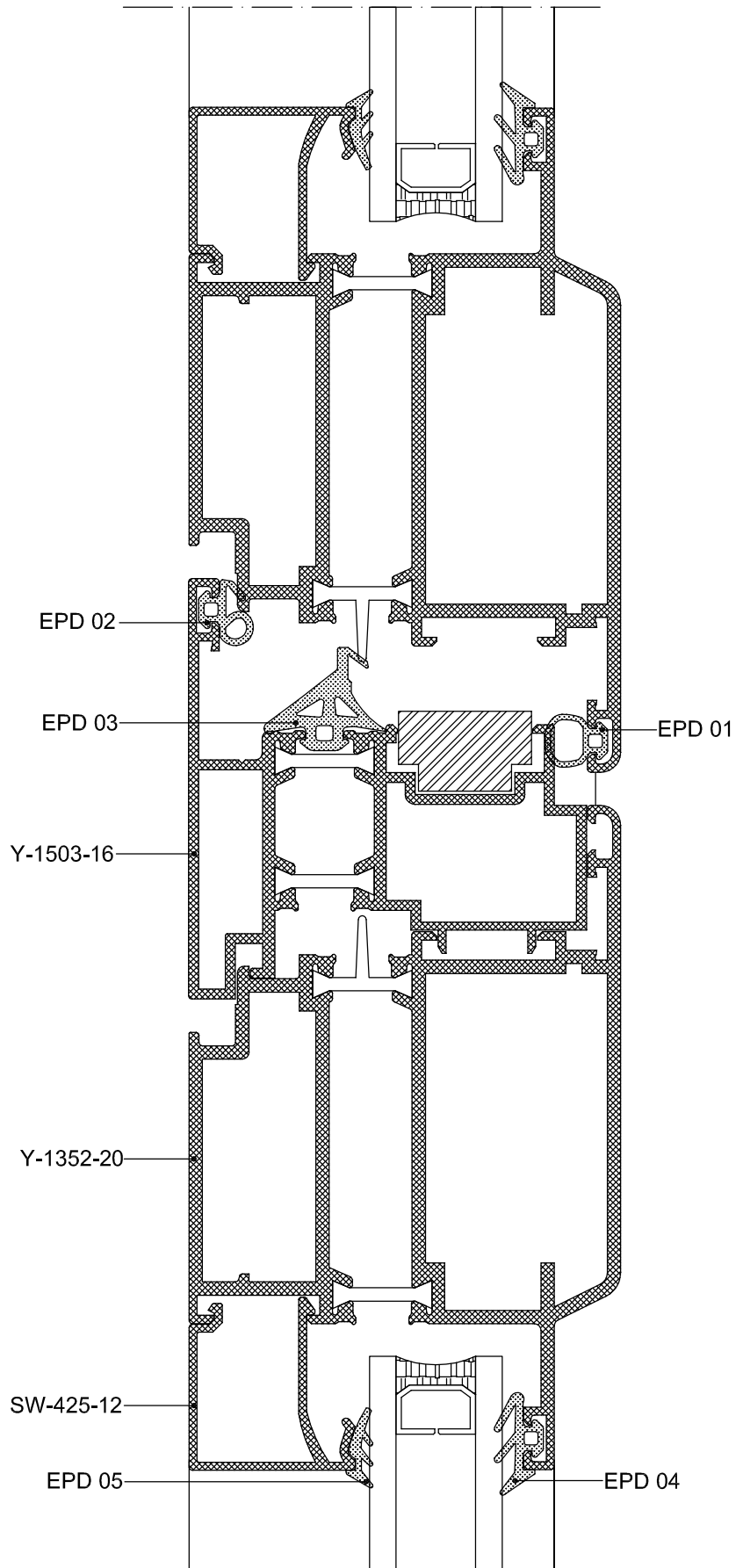

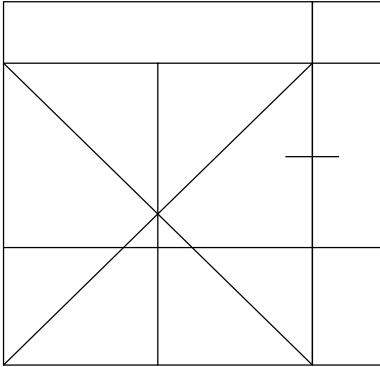

46

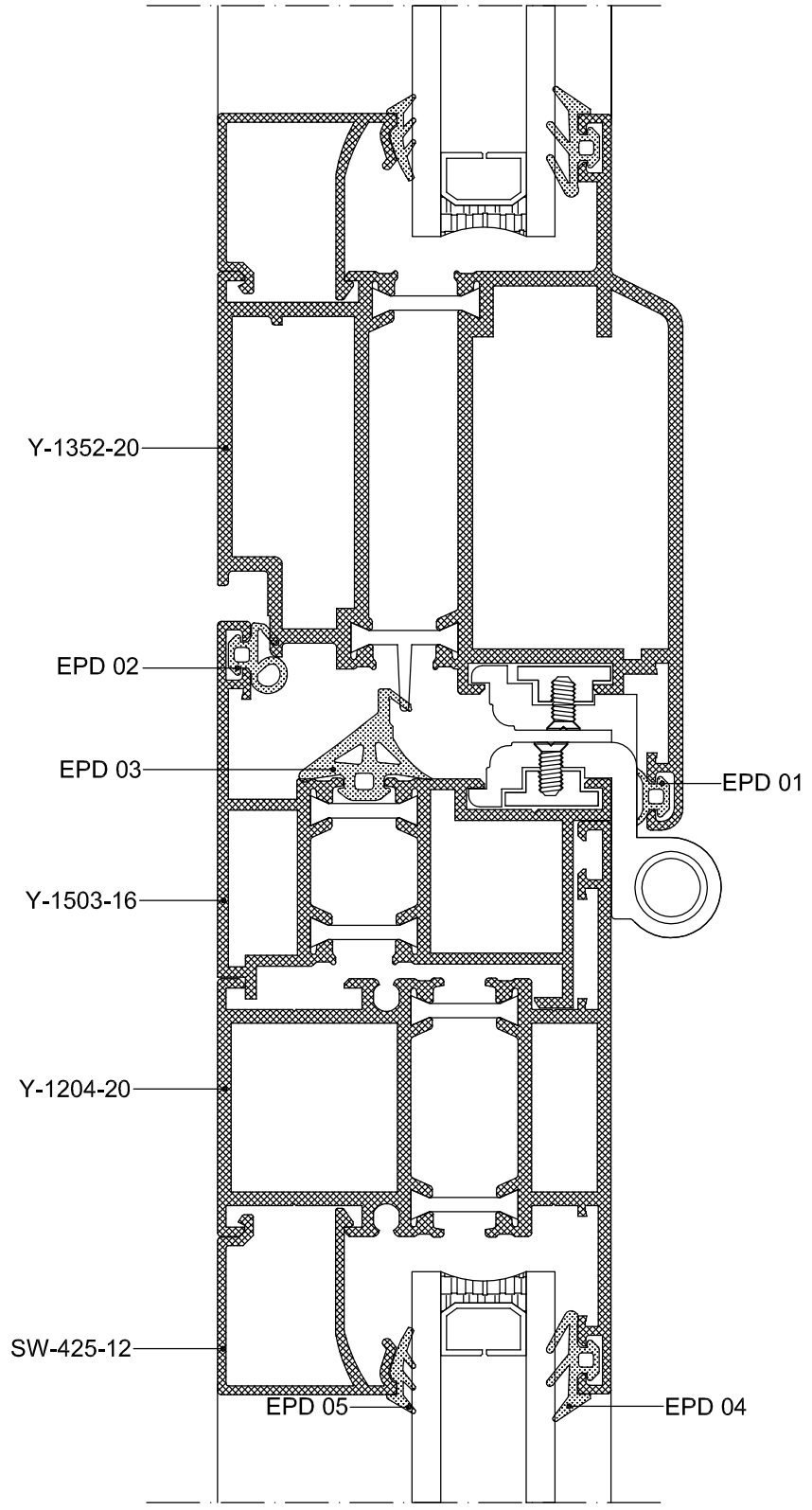

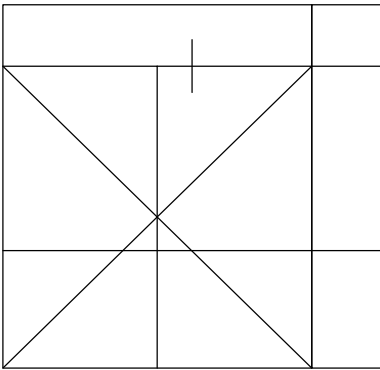

47

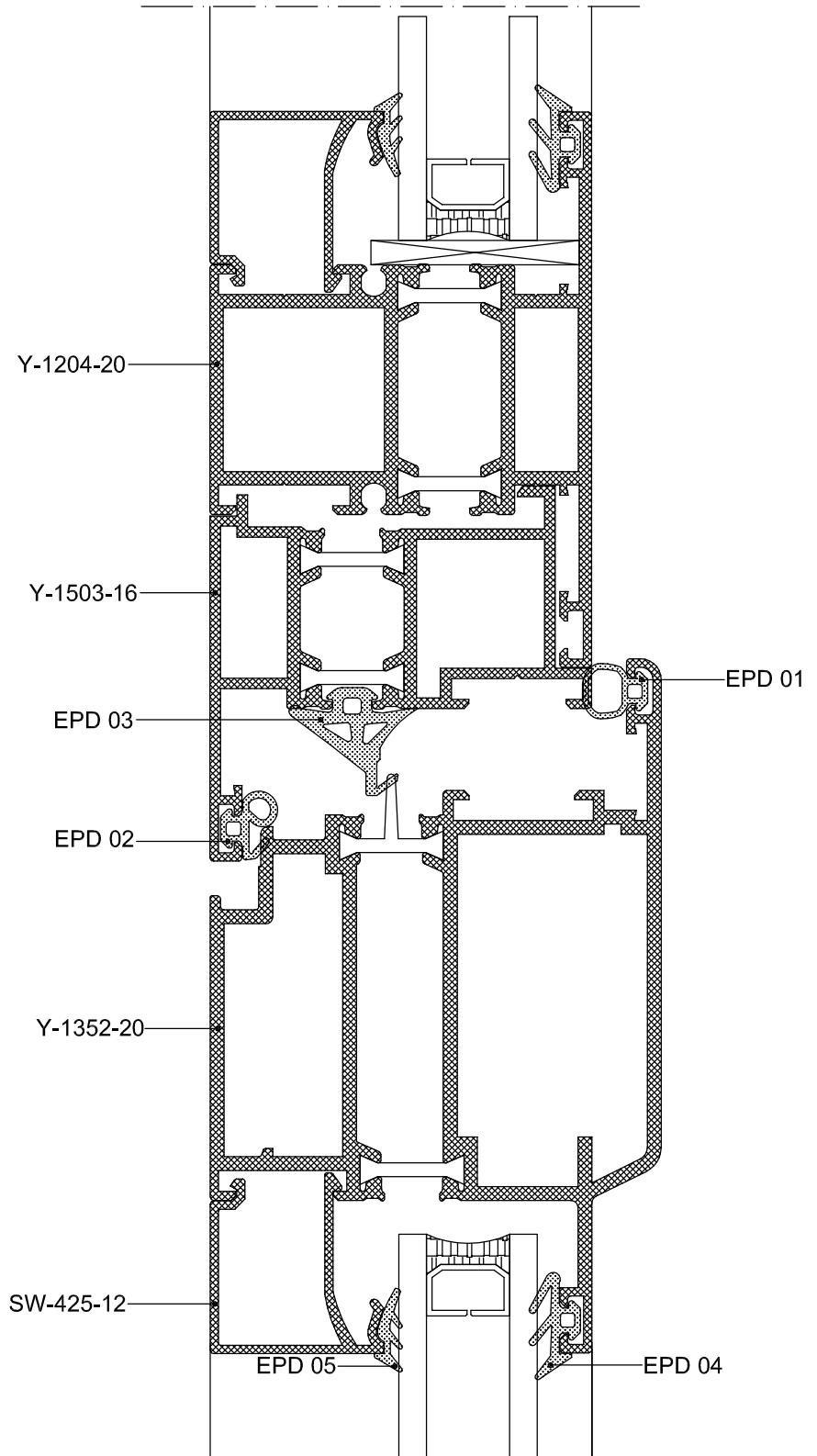

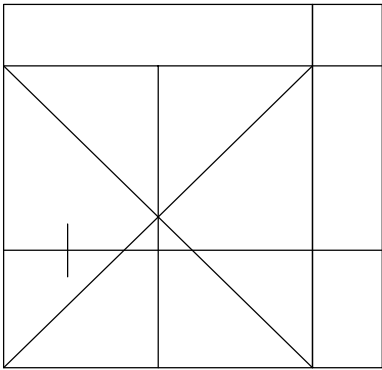

48

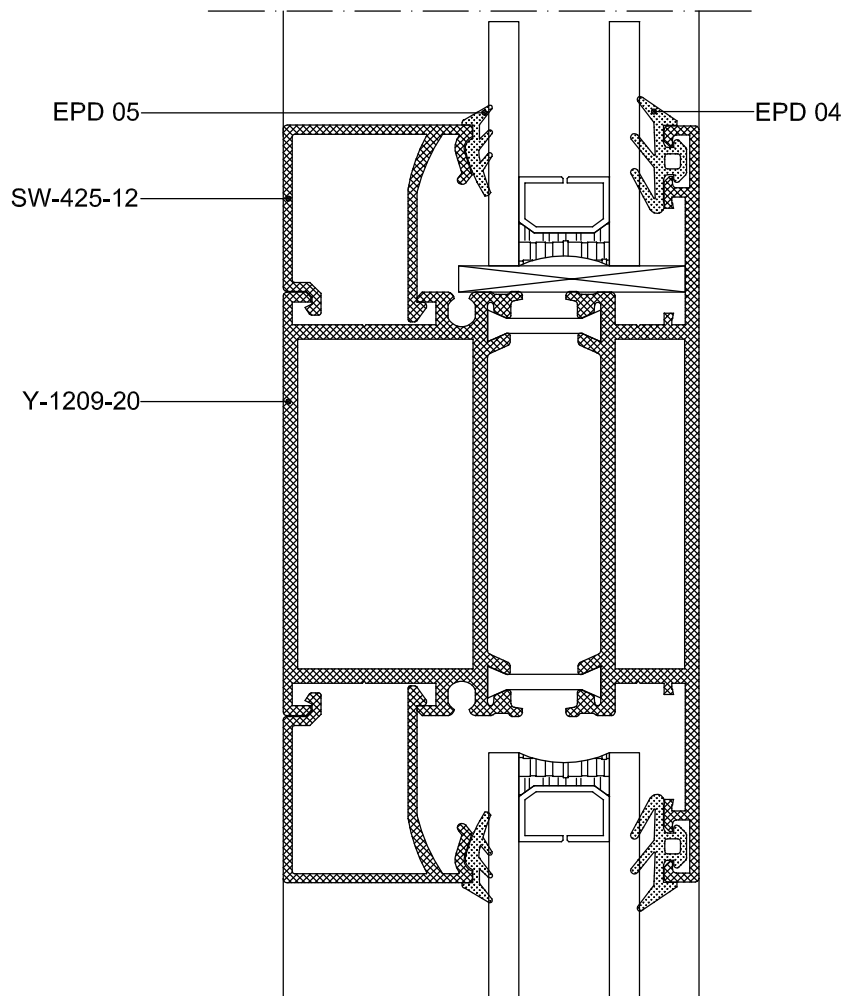

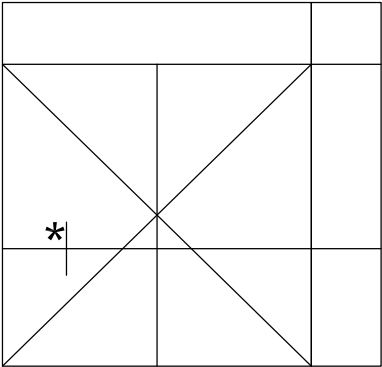

49

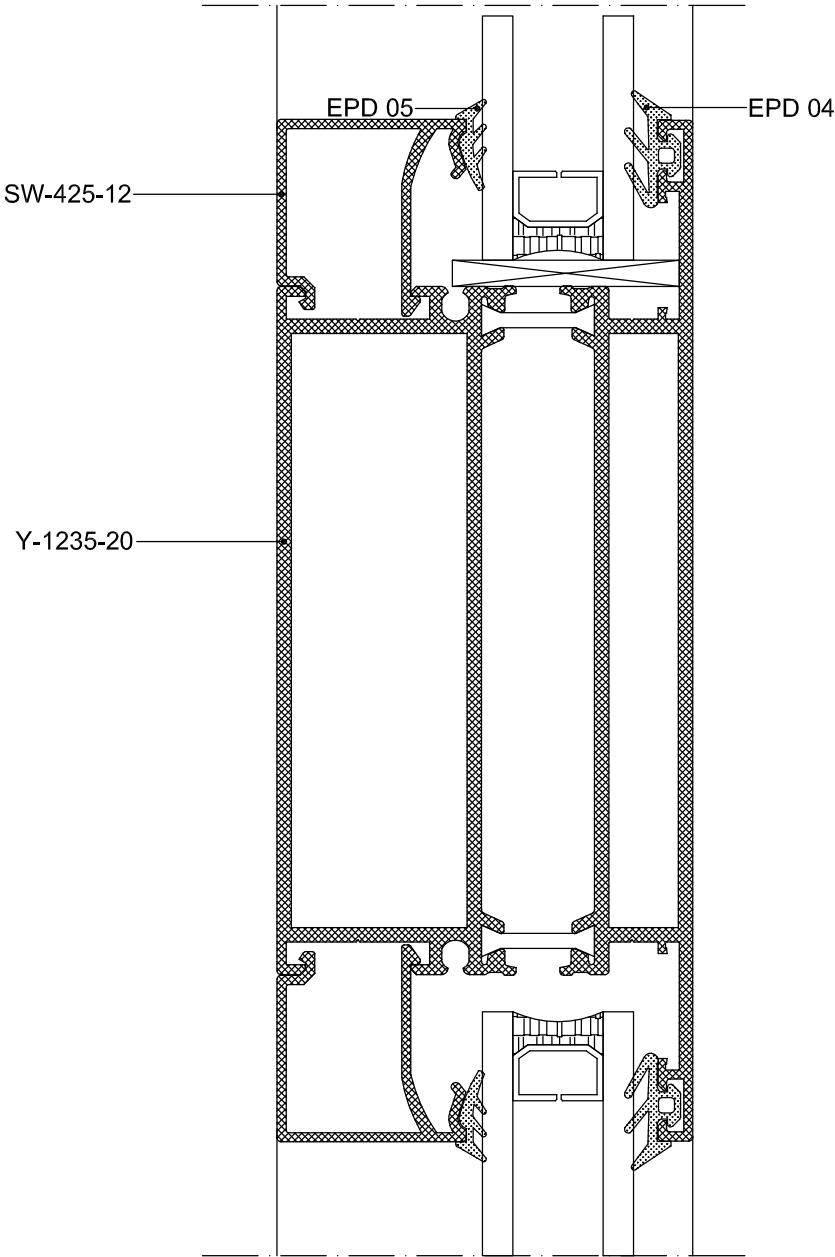

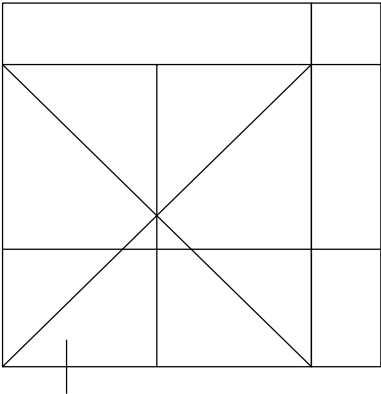

50

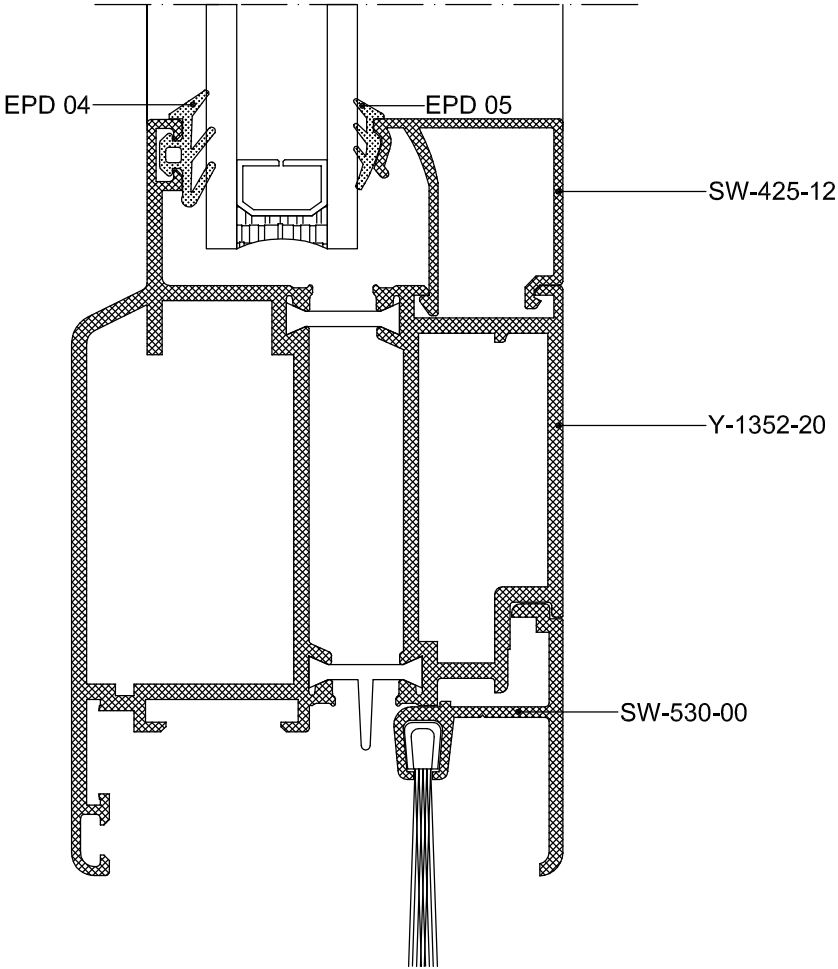

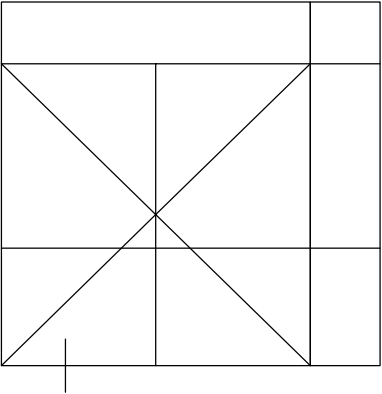

51

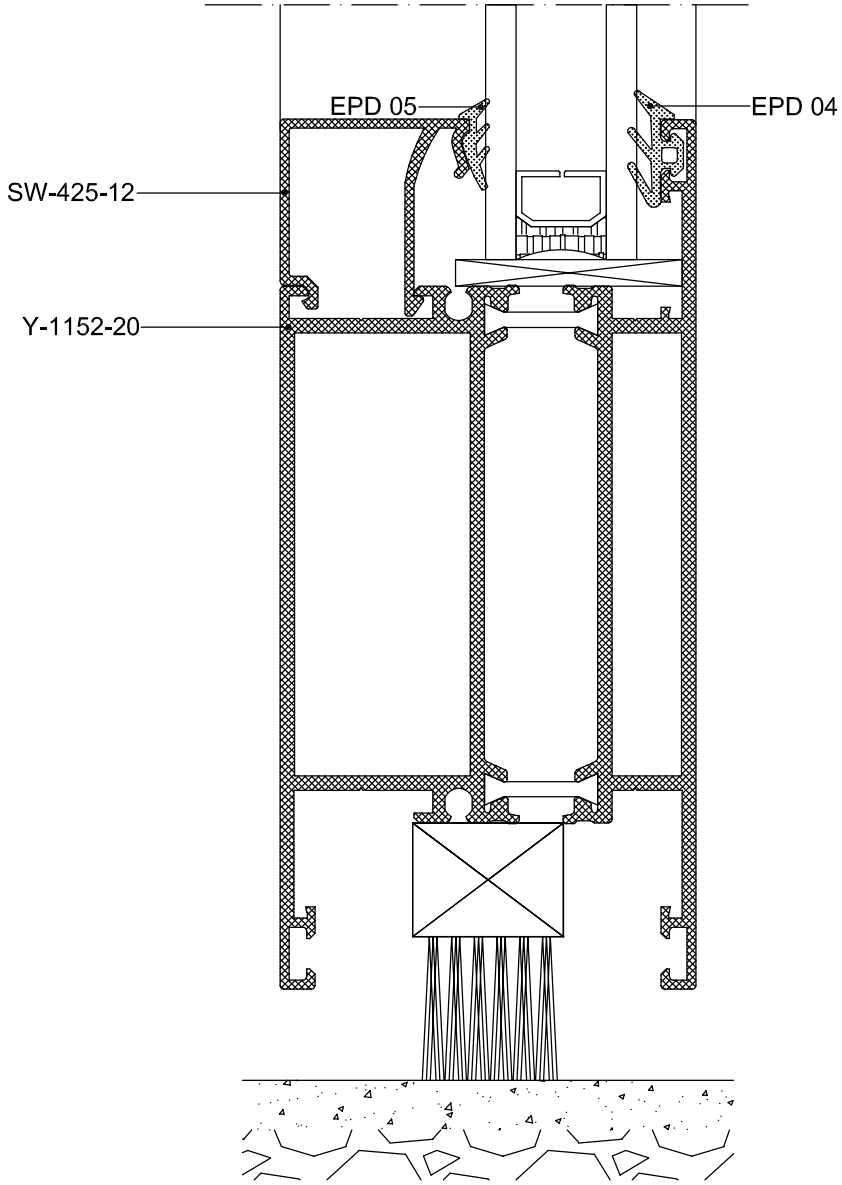

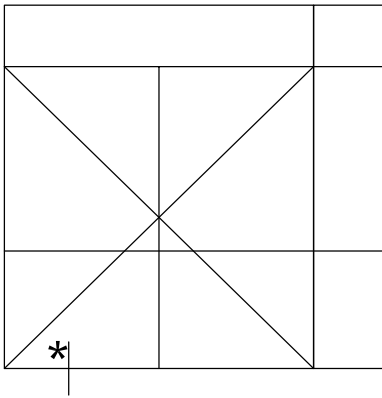

52

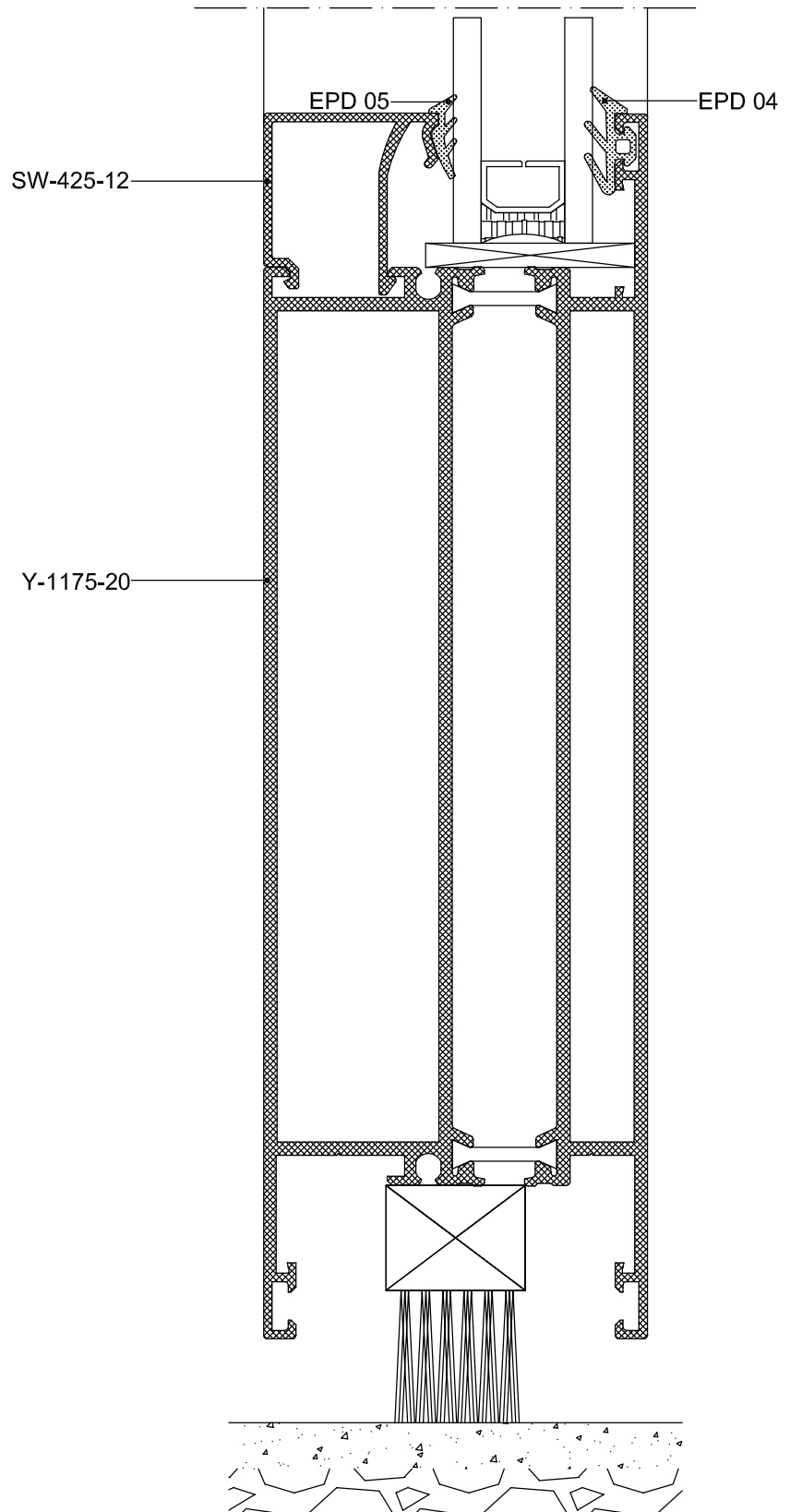

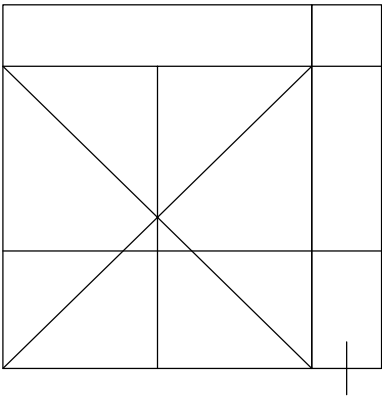

53

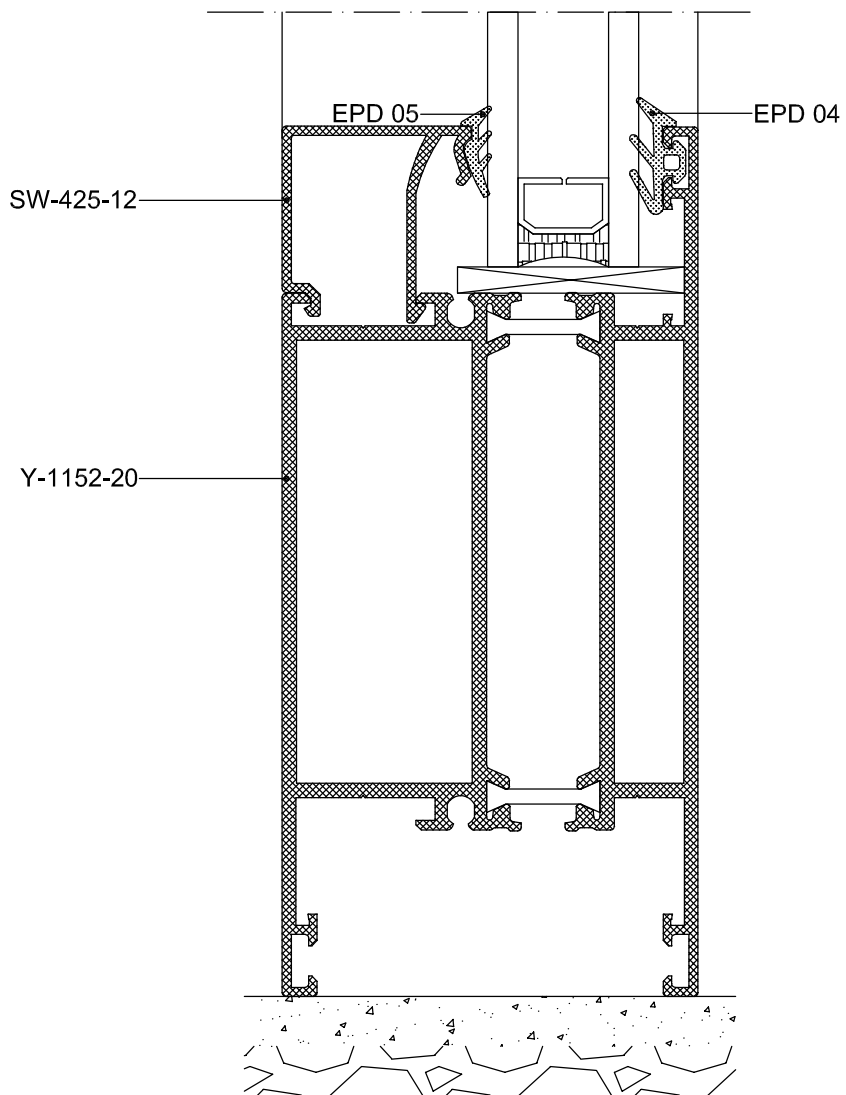

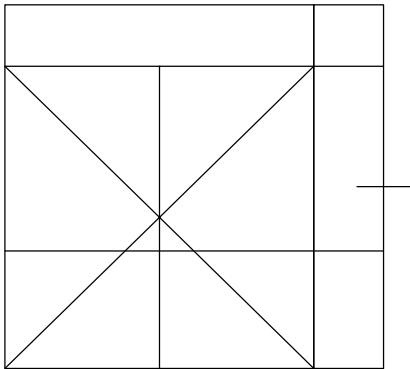

54

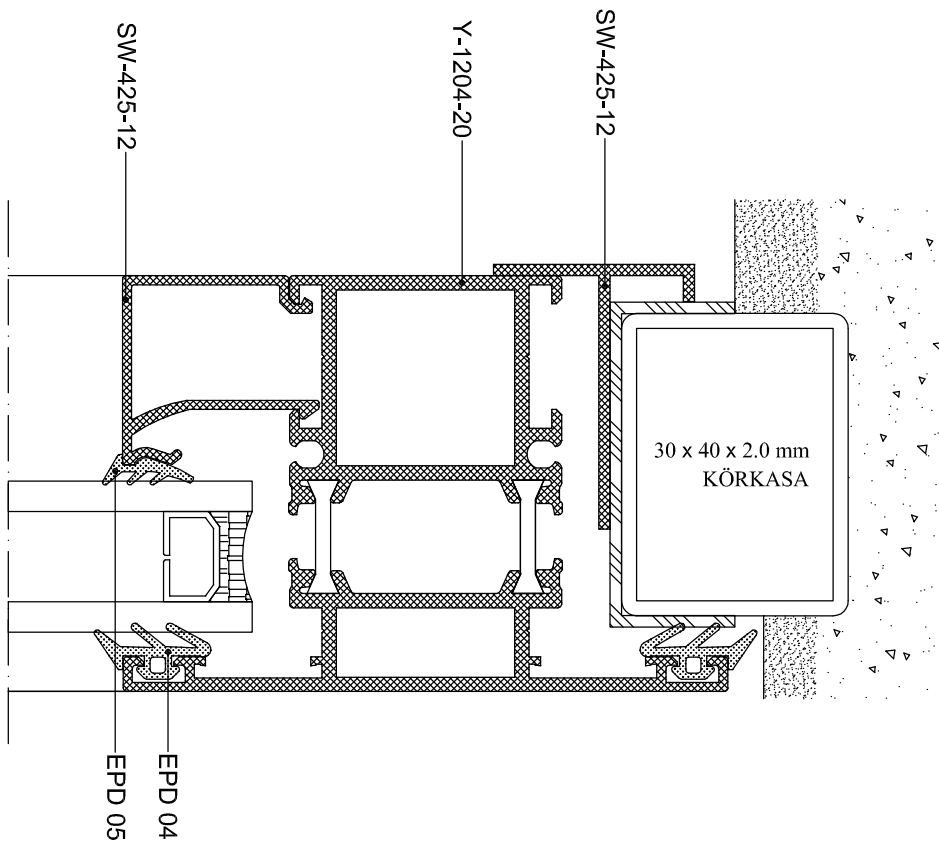

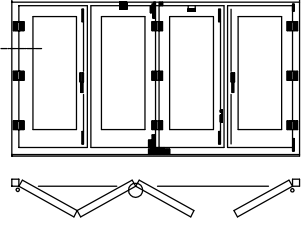

AY-55 YALITIMLI DOĞRAMA SİSTEMİ İLE
KATLANIR KAPI DETAYI

55

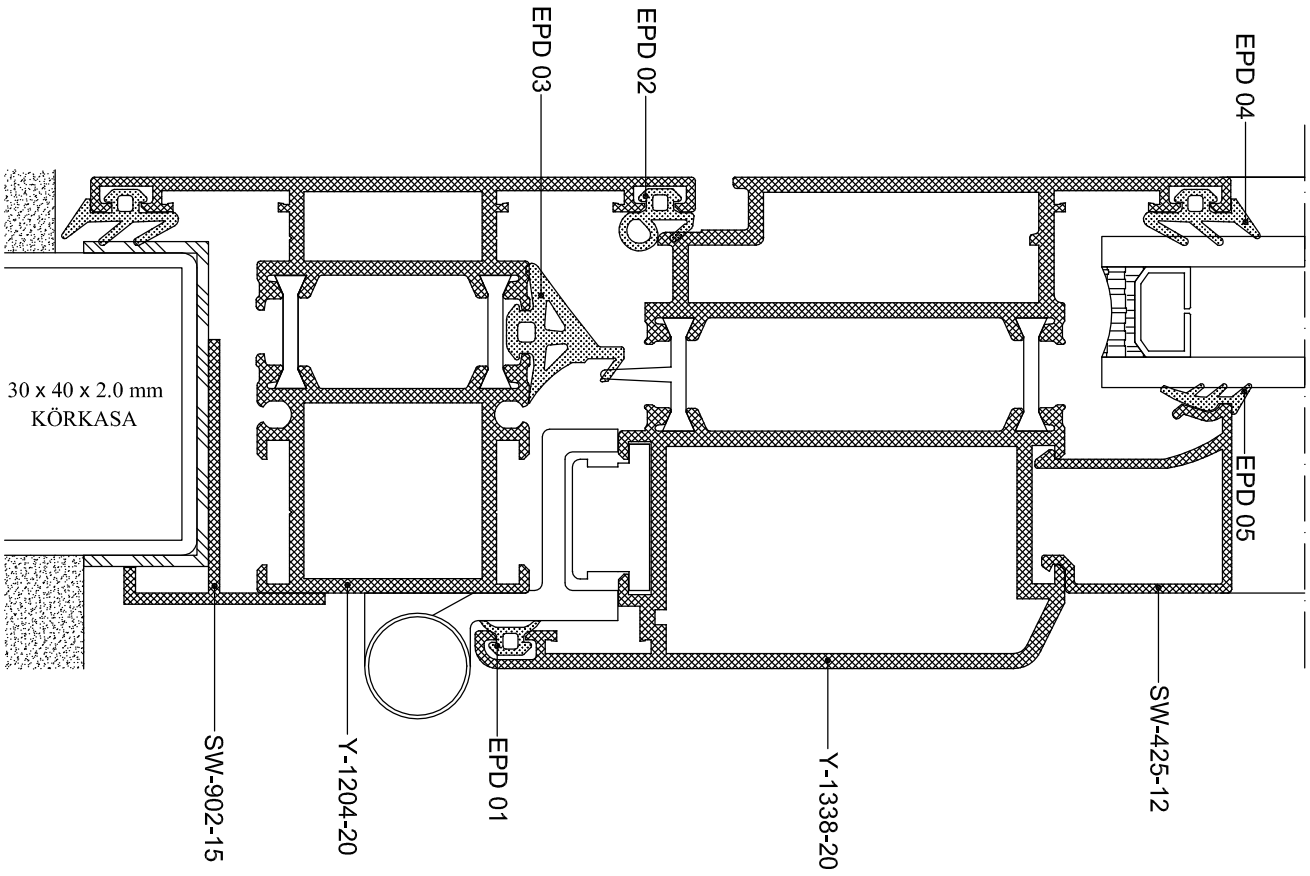

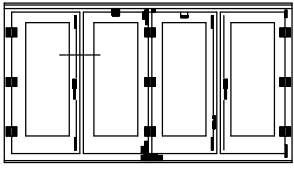

56

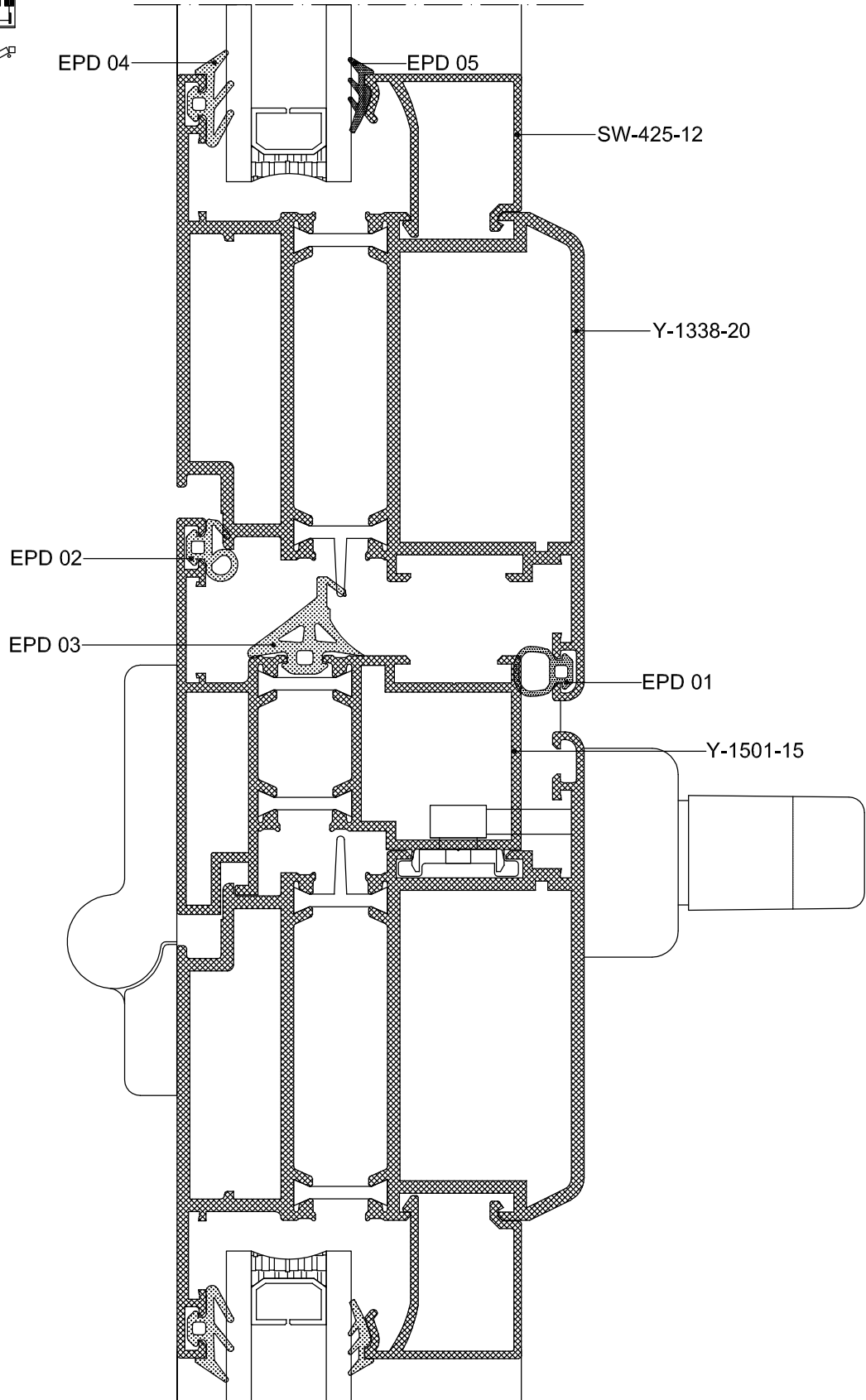

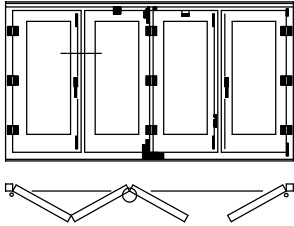

57

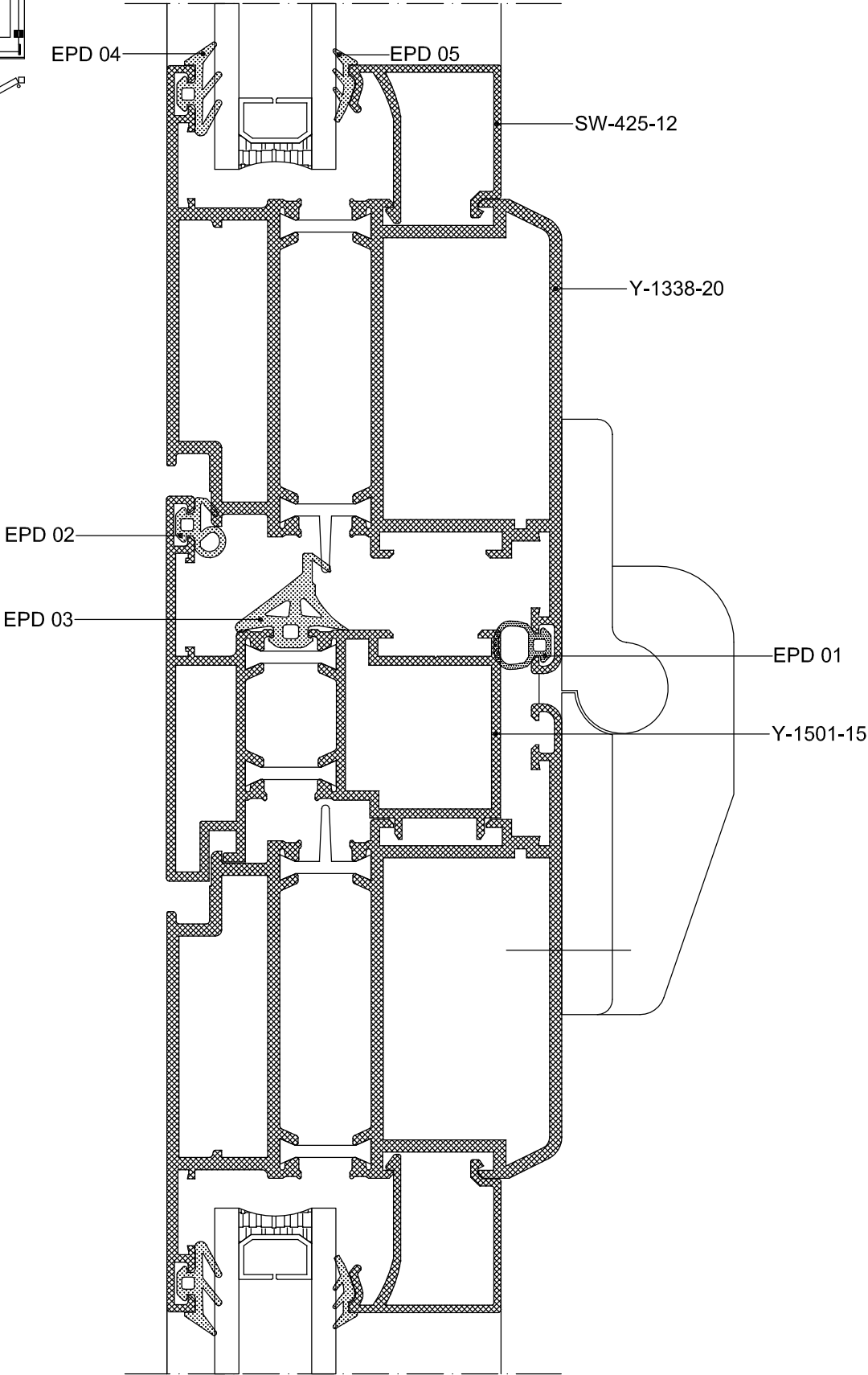

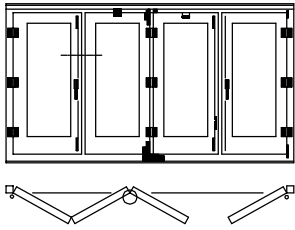

58

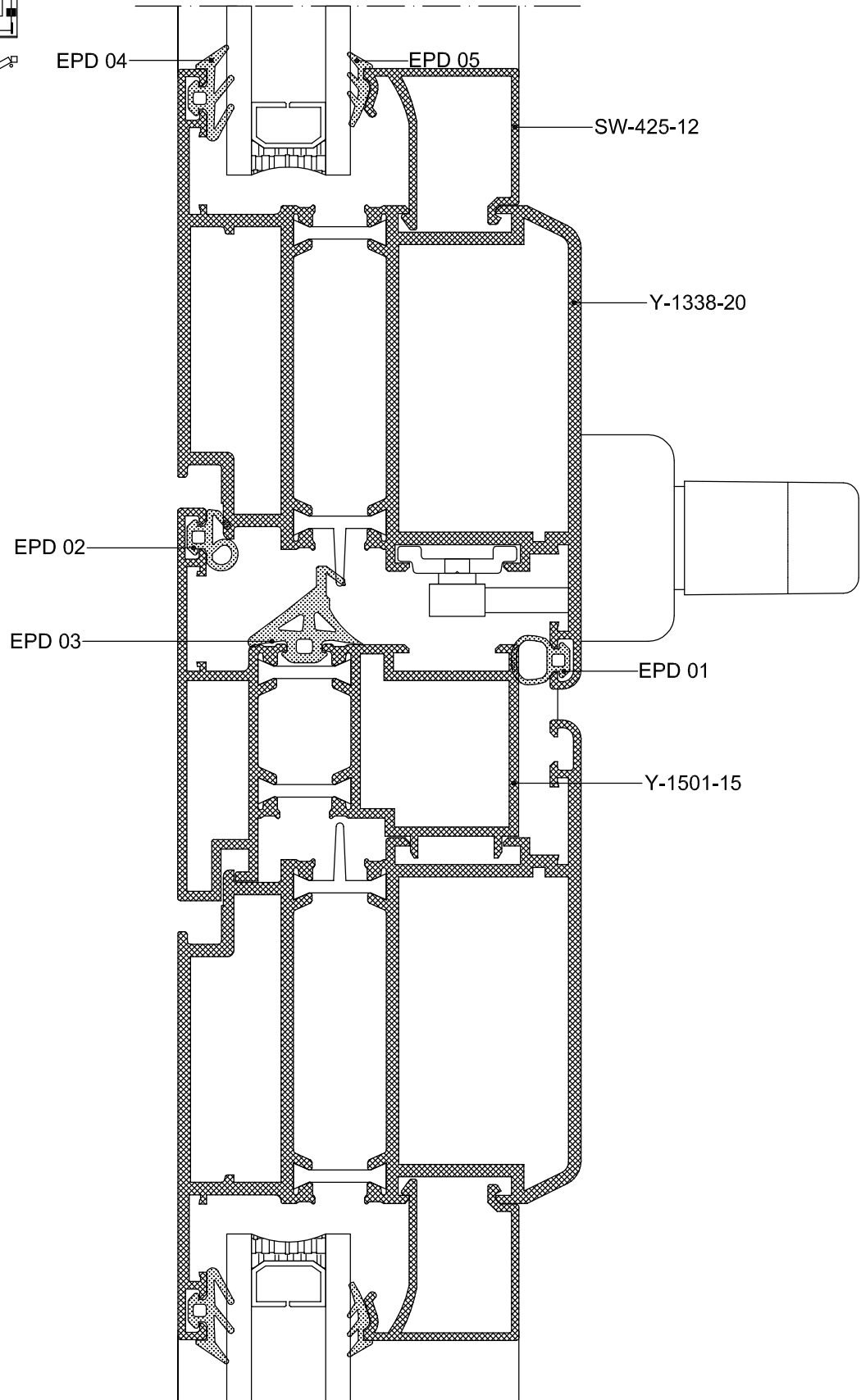

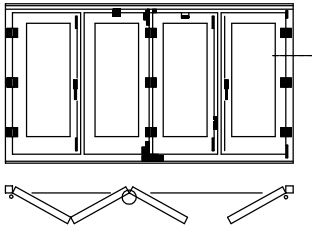

59

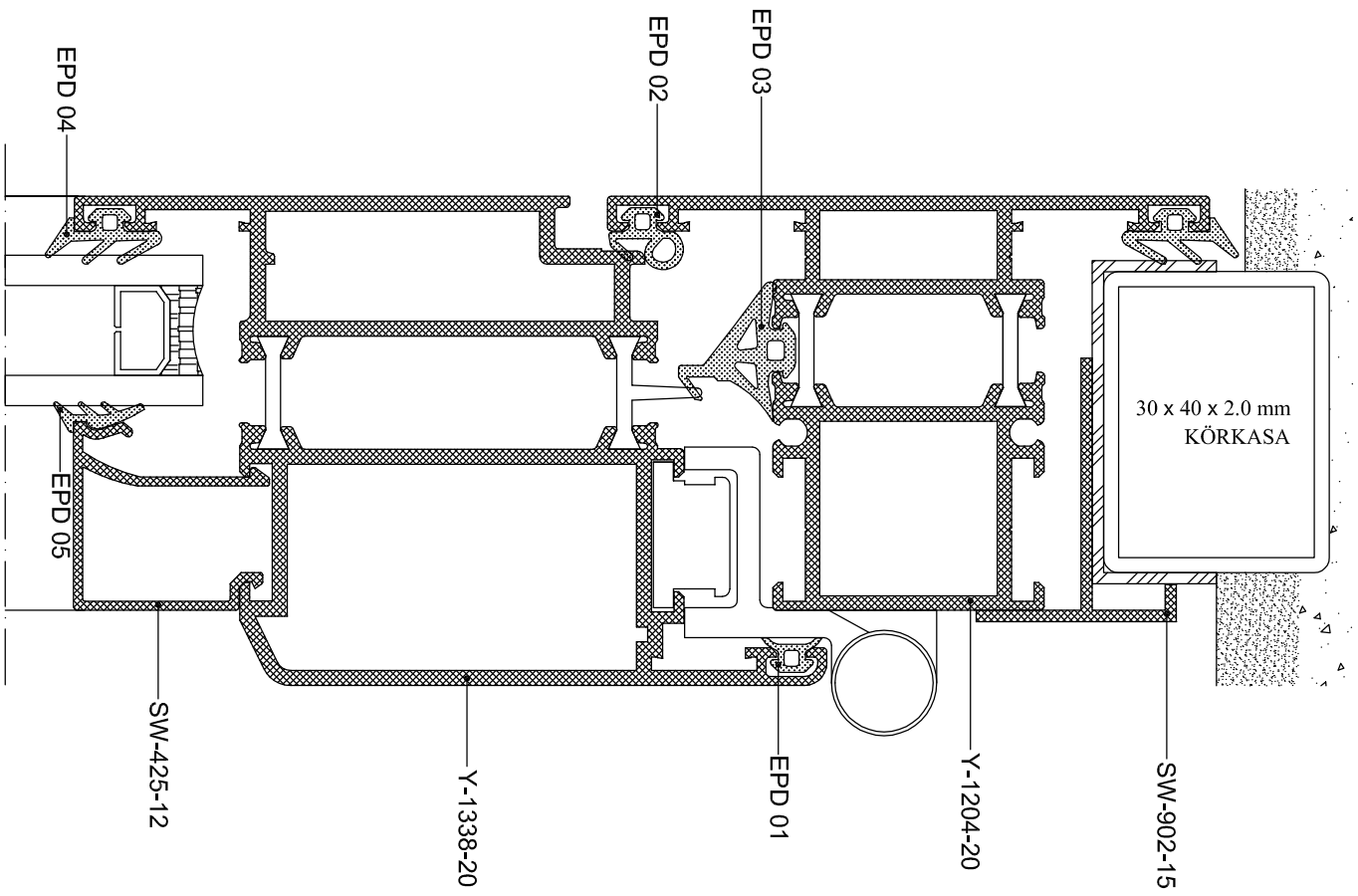

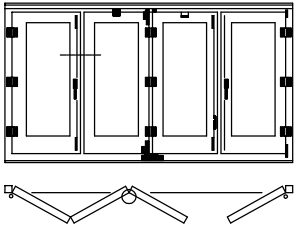

60

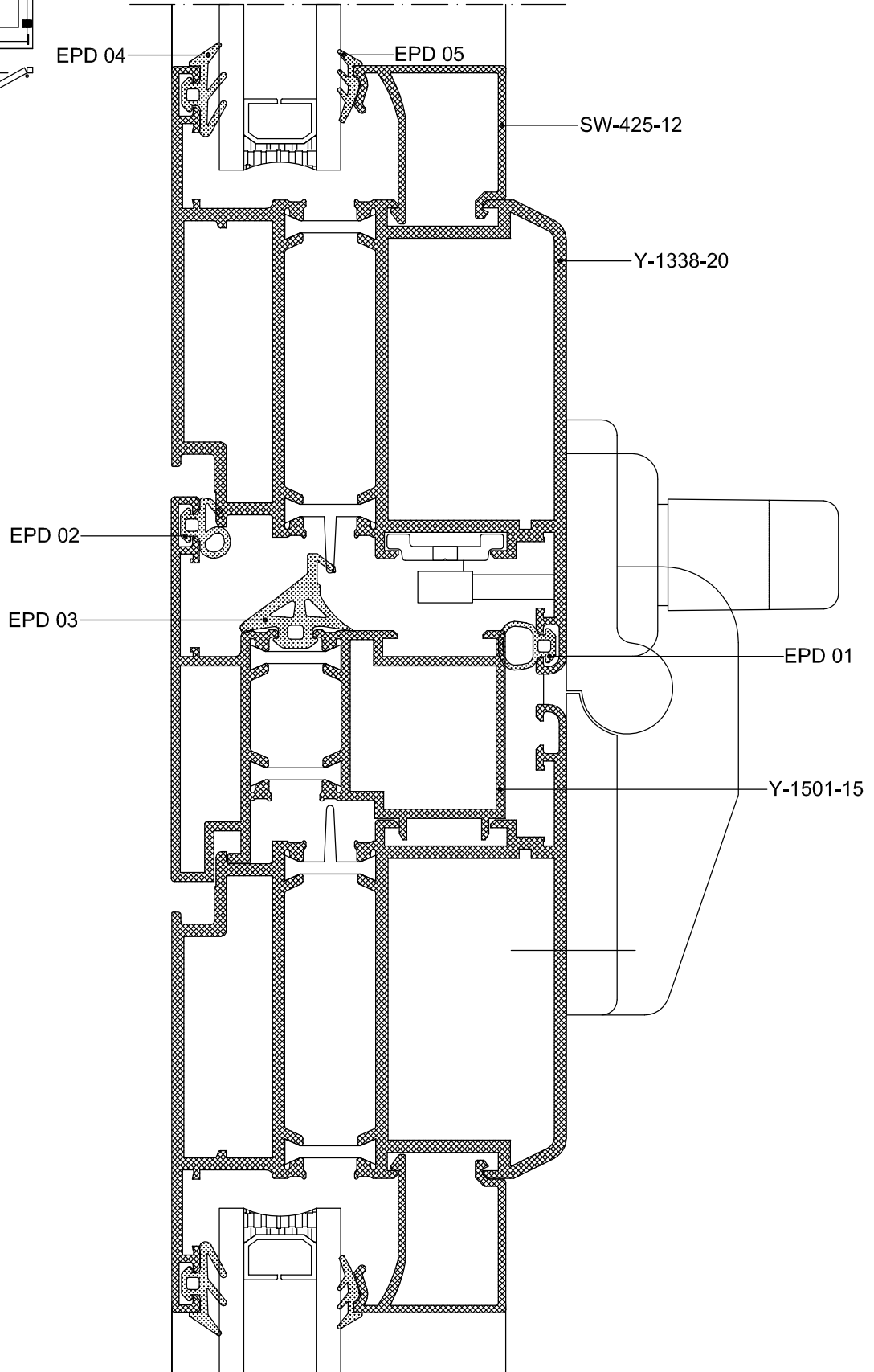

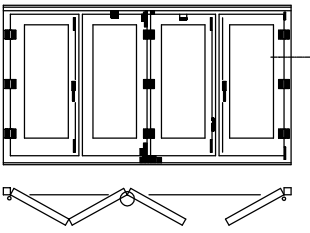

61

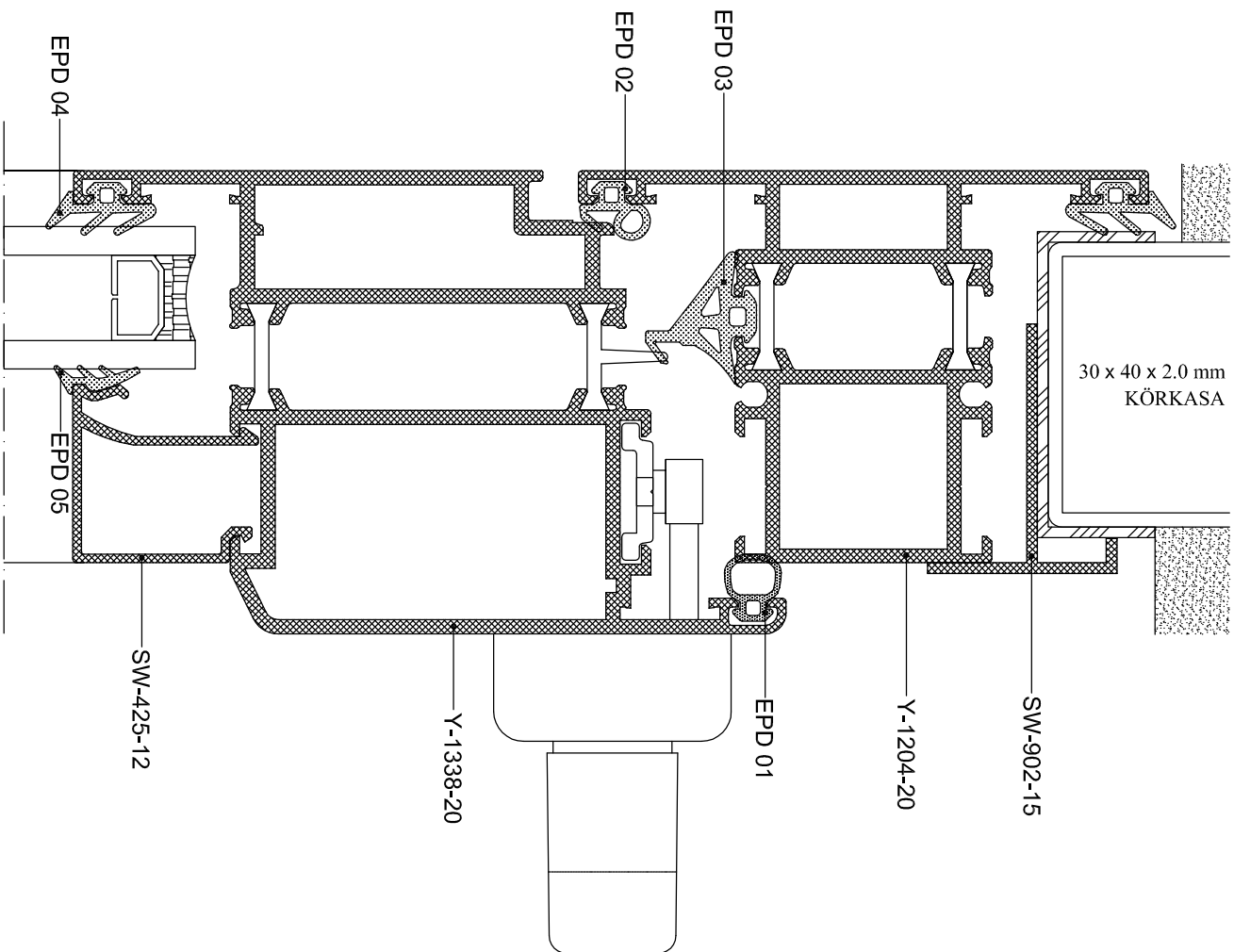

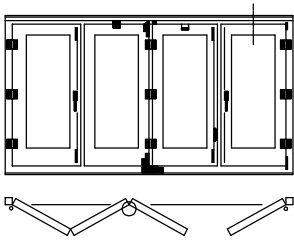

62

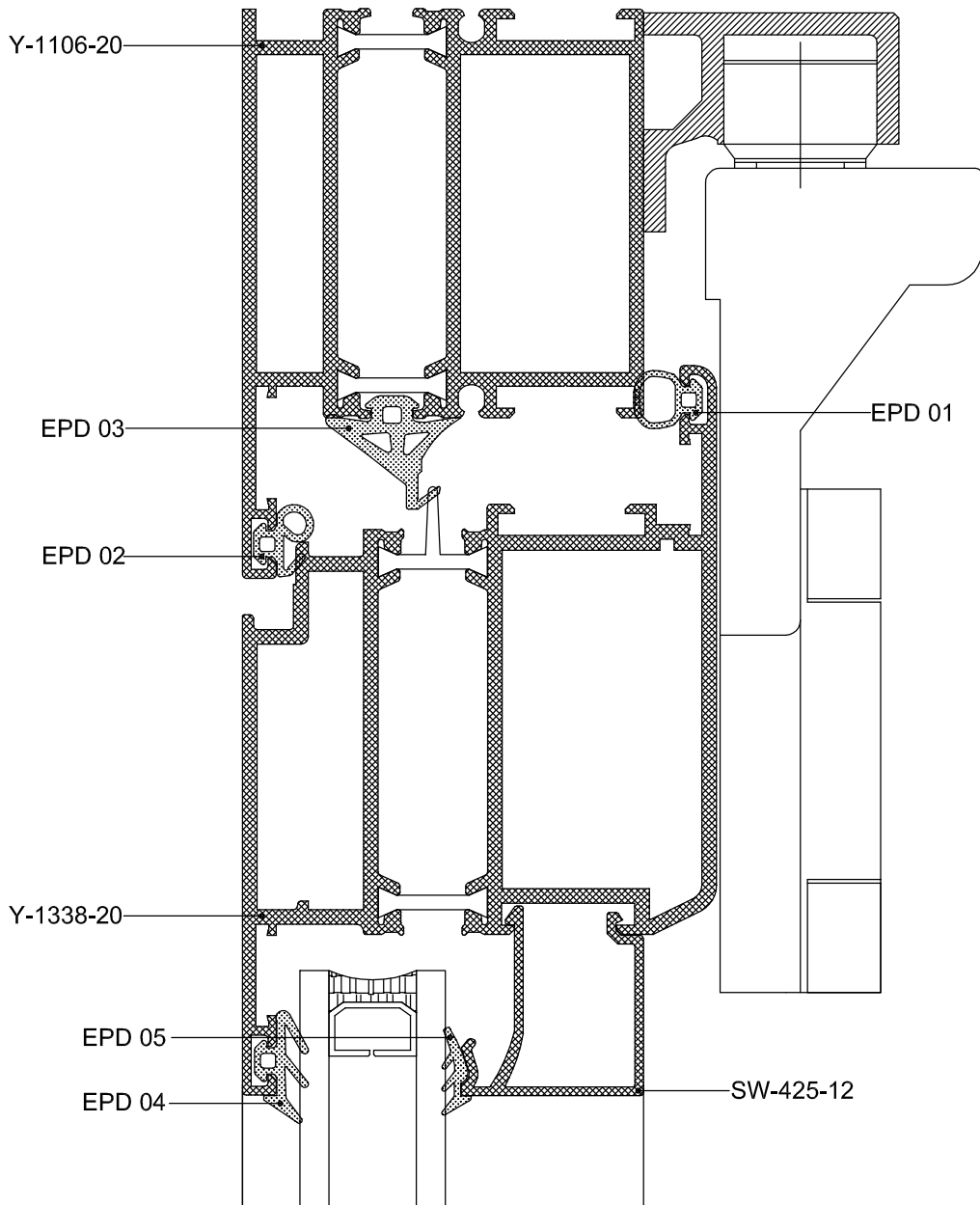

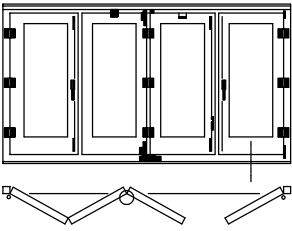

63

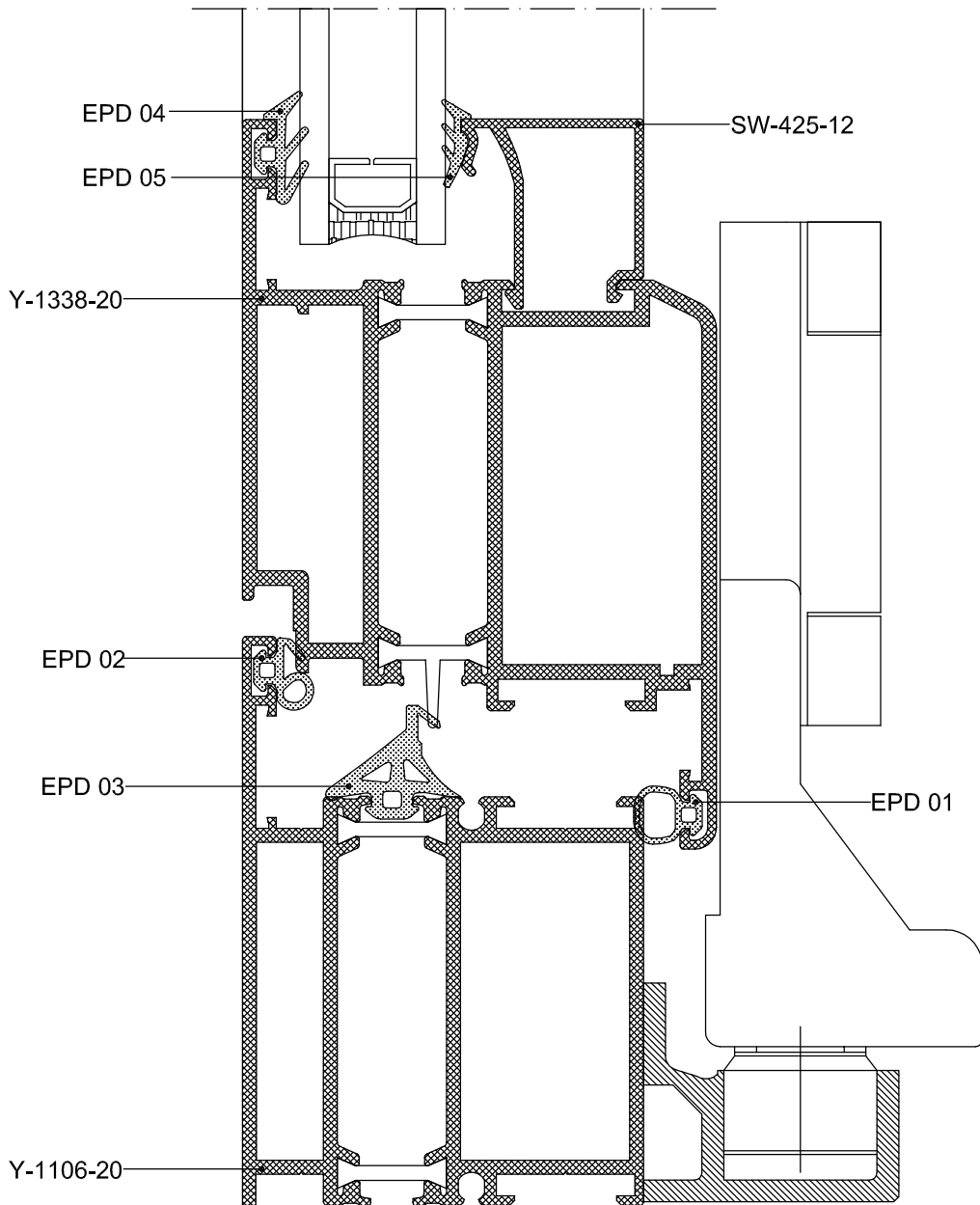

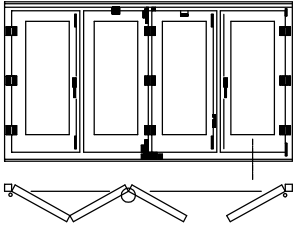

64

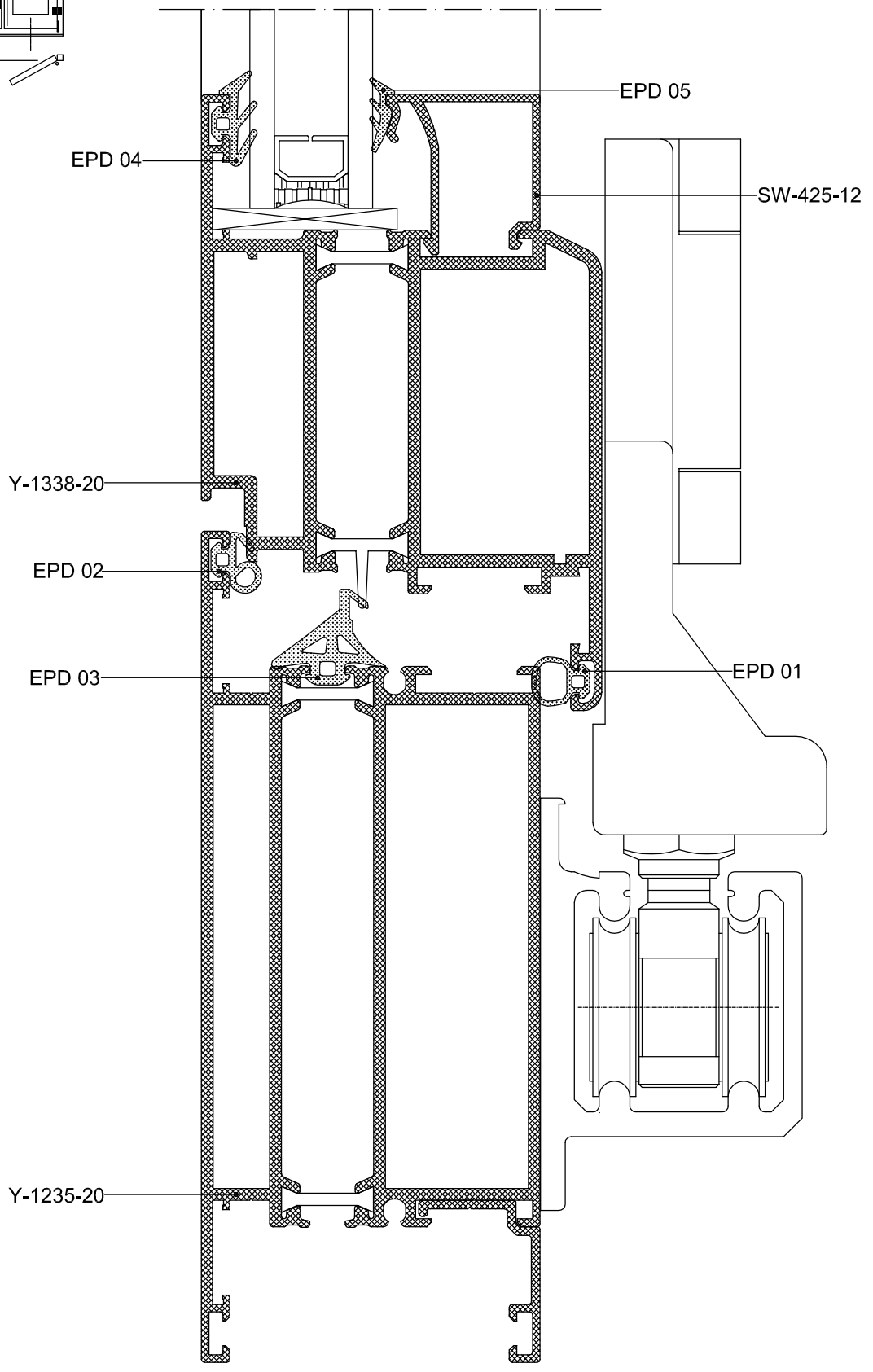

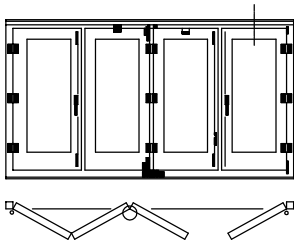

65

Y-1235-20

EPD 03

EPD 02

Y-1338-20

EPD 04

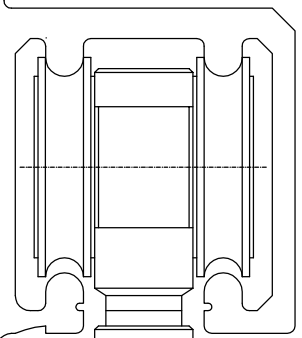

EPD 01

SW-425-12

EPD 05

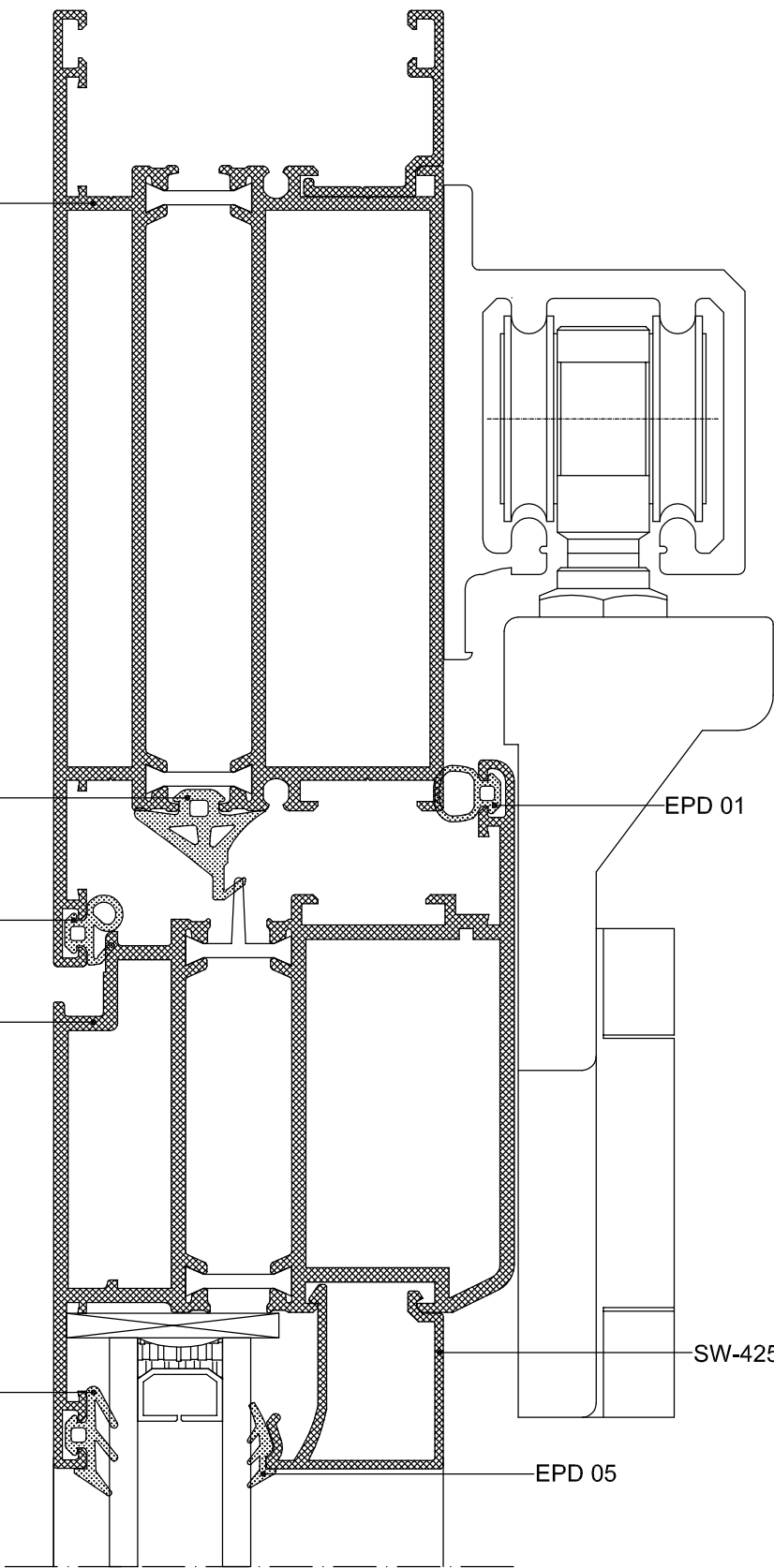



ALUFOUR

YALITIMLI DOĞRAMA SİSTEMİ